

Emergency Vehicle Operator Course (Ambulance)

National Standard Curriculum



Participant Manual 1995



PREFACE

The U.S. Department of Transportation (DOT), National Highway Traffic Safety Administration (NHTSA) has the responsibility for the development of training courses that are responsive to the guidelines established by the Highway Safety Act of 1966 (amended). One of the most compelling highway safety justifications for an Emergency Vehicle Operators Course is that such a course would reduce the incidence of emergency vehicle collisions. In 1978, NHTSA developed the: Training Program for Operation of Emergency Vehicles: A National Standard Curriculum (EVOC). Vehicle technology and ambulance design have moved rapidly since 1978. In order for DOT curricula to be responsive to the constituency it must serve, curricula must be accurate, current, and assure that effective adult learning techniques are utilized.

The 1978 edition of the EVOC course has been revised to the Emergency Vehicle Operator Course (Ambulance): National Standard Curriculum, to ensure that it is accurate, current, and that it incorporates adult learning strategies. The revised curriculum will address only emergency vehicle operations as they relate to the operation of ambulances. The new course is recommended for anyone who operates an ambulance. The revised curriculum is appropriate for either rural or urban operations. The curriculum is made up of an instructor guide and participant manual which allow for the inclusion of local and State laws and organizational operation procedures. The revised curriculum will consist of three modules. Module A is approximately sixteen hours of classroom teaching. Module B allows participants to practice ambulance operator skills on a driving range and includes a driving range practice checklist. Module C is designed to provide an on-the-job performance assessment of the skills learned in the course through the use of an on-the-job checklist.

The Emergency Vehicle Operator Course (Ambulance) curriculum provides the knowledge and skill practice necessary for individuals to learn how to safely operate all types of ambulances.

ACKNOWLEDGEMENT

Star Mountain, Inc. of Alexandria, Virginia was selected to revise the EVOC. They were charged with developing a user friendly curriculum geared to adult learners that could be utilized by the States in their efforts to standardize ambulance operation training. Star Mountain utilized a NHTSA sponsored Curriculum Development Group (CDG) representing five major Emergency Medical Service organizations. The CDG was actively involved in the design and review of the revised curriculum. NHTSA gratefully acknowledges the contributions of the CDG members and the organizations they represented.

Curriculum Development Group (CDG)

National Council of State EMS Training Coordinators
Representative: Gail A. Stewart, EMT-P

American Society for Testing and Materials
Representative: James A. Lawrence, RN, EMT-P

National Association of State EMS Directors
Representative: Dan Manz, EMT-D

National Association of Emergency Medical Technicians
Representative: Patrick Moore, EMT-I

American Ambulance Association
Representative: Bill Leonard

Organizations Visited

Star Mountain visited the following organizations to collect information on ambulance operations. The information was used to prepare the working documents for the CDG meeting. NHTSA greatly appreciated the full cooperation of these organizations.

District of Columbia Fire Department Training Academy

Virginia Association of Volunteer Rescue Squads, Inc.
Forest View Rescue, Chesterfield, Virginia
Volunteer Rescue Squad, Madison County, Virginia

Maryland Institute of Emergency Medical Services
Community Rescue Service, Inc. Hagerstown, Maryland
Fire Training Academy, Anne Arundel County, Maryland

Federal Agencies

General Services Administration. M.L. Globerman, Chief, Vehicle Engineering Branch was very helpful in reviewing the curriculum involving the ambulance specifications. He also provided expert advice on the Federal Specification for Ambulances, Emergency Medical Care Surface Vehicles, KKK-A-1822C.

United States Fire Administration. William J. Troup provided numerous documents and contributed to the discussions about the overall curriculum development.

Individuals

Many individuals contributed by providing comments and ideas for the revision of the curriculum. The dedicated people doing the job as paid and volunteer Emergency Medical Technicians, Paramedics and Ambulance Operators were an inspiration for this program.

PILOT TESTS

Pennsylvania and Florida were selected to support the pilot testing because both require training for ambulance operators. Star Mountain conducted instructor training at the County of Bucks in Pennsylvania for rural operations and Randle-Eastern Ambulance Service, Inc., an American Medical Response, Inc. company in Miami, Florida for urban operations.

Joseph W. Schmider, Director, Department of Emergency Health Services, County of Bucks, coordinated the instructor training and conduct of the course by the recently trained instructors. Because most of the participants in Bucks County were volunteers, the course was conducted over two weekends.

Robert W. Trinkleback, CSP, Corporate Director of Safety and Health coordinated the American Medical Response participation. Captain Robert R. Crowel, Director, Safety/Risk Management at Randle-Eastern coordinated the instructor training and conduct of the course during three days of training.

The instructors did an excellent job of integrating the state, local and organizational requirements into the curriculum. The participant and instructor evaluations of the course were excellent. NHTSA appreciated the outstanding support at both of these organizations.

ORGANIZING YOUR PARTICIPANT MANUAL

It is recommended that each user obtain separator sheets with tabs to separate the modules, lessons within each module, and the appendixes. You will need separators labeled A, B, and C for the Modules. Module A has 10 lessons and the Appendixes go from A to G. Adding the separators with tabs will make it easier to use the participant manual.

TABLE OF CONTENTS

MODULE A

	Page
Lesson 1 - Introduction to the National Standard Curriculum for Ambulance Operations.....	1-1
Lesson 2 - Legal Aspects of Ambulance Operation	2-1
Lesson 3 - Communication and Reporting Roles and Responsibilities.....	3-1
Lesson 4 - Ambulance Type and Operation.....	4-1
Lesson 5 - Ambulance Inspection, Maintenance, and Repair.....	5-1
Lesson 6 - Navigation and Route Planning	6-1
Lesson 7 - Basic Maneuvers and Normal Operating Situations	7-1
Lesson 8 - Operations in Emergency Mode and Unusual Situations.....	8-1
Lesson 9 - Safety: Special Considerations.....	9-1
Lesson 10 - The Run.....	10-1

MODULE B

Ambulance Operation: Demonstration and Practice.....	1
--	---

MODULE C

Ambulance Operator Internship: Guidelines For Additional On-The-Job Training and Documentation.....	1
--	---

APPENDIXES





Appendix A - Area Motor Vehicle Operation Guidelines.....	A
Appendix B - Interpreting Hand Signals.....	B
Appendix C - Sample Checklist: Quick Check.....	C
Appendix D - Sample Checklist: Full Check.....	D
Appendix E - Sample Work request.....	E
Appendix F - Glossary.....	F
Appendix G - References.....	G

COURSE:	EMERGENCY VEHICLE OPERATOR COURSE (AMBULANCE): NATIONAL STANDARD CURRICULUM
MODULE A:	Ambulance Operation: The Basics
LESSON 1:	Introduction to the National Standard Curriculum for Ambulance Operators
COURSE GOAL:	To provide ambulance operators with knowledge and skills to operate their vehicles so that vehicle, equipment, crew, and patients will be delivered safely and efficiently, and the safety of the public will be assured during all phases of the delivery of Emergency Medical Services (EMS) involving the ambulance
MODULE GOAL:	To provide ambulance operators with the knowledge required to safely and efficiently operate an ambulance in both nonemergency and emergency modes
LESSON GOAL:	To introduce the course by describing its organization and schedule and reviewing course materials
PERFORMANCE OBJECTIVE(S):	<ul style="list-style-type: none"> ● Identify ambulance operator selection requirements
PM APPENDIX:	

**PARTICIPANT
MATERIALS:**

Participant Manual

ICON LEGEND

			
Notes	Response	Appendix	Local Requirements

INTRODUCTION

Welcome



Participant Introductions



COURSE OVERVIEW

In this course you will learn about--

- legal aspects of ambulance operation, including appropriate vehicle procedures based upon federal, state, local, and organization regulations; due regard; true emergencies; negligence; abandonment; good Samaritan provisions; and patient's rights.
- communications responsibilities for receiving and sending radio messages and for interpreting hand signals
- ambulance types and operation, including general guidelines about

weight restrictions and operation for each type

- ambulance readiness, including inspection, maintenance, and repair
- navigation and route planning, including selecting the safest route to the emergency scene and the medical facility
- normal and high-risk driving situations and the appropriate driving skills for situations from routine traffic to hazardous weather and traffic conditions
- safety considerations for ensuring safety of passengers, patients and their family, the ambulance, and the crew

MODULE OVERVIEWS

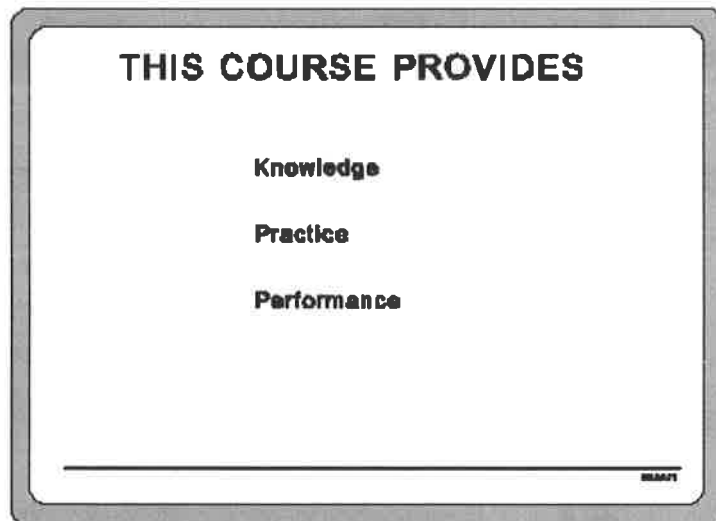

This course will provide the following:

First: the **knowledge** you need to operate your vehicle safely and efficiently. This information is contained in Module A.

Second: recommendations and methods for **practice**. This information is contained in Module B.

Third: methods for evaluating your **performance** on-the-job. This information is contained in Module C.

Module A provides learning evaluation using a brief multiple choice test on the information we cover during this class.

Module B provides a series of checklists that you will be evaluated on while driving on a protected range.

And Module C provides a series of checklists that can be used by your supervisors to provide you with feedback on your performance of ambulance operator duties on the job.

This course will not cover pursuit driving or high-speed operation of an ambulance. The statistics are overwhelming in favor of operating at or below the posted speed limits and getting to the scene safely.

Once you have your ambulance at the scene and patient care begins, the chances are that the patient will survive.

You will also learn that with the patient on board you want to provide the

smoothest ride possible in a nonemergency mode. Statistics show that if the patient gets to the medical facility within one hour, the chances of surviving are greater than 90 percent.

Relationship to Other NHTSA courses

This course is part of the National Standard Curricula being developed or revised by the National Highway Traffic Safety Administration (NHTSA) for EMS providers. That curriculum includes training for bystanders, for first responders, for Emergency Medical Technicians (EMT-B, EMT-I, and EMT-P), for dispatchers, and EMS Instructors.

Schedule

The course instructor will provide a schedule for the course.



TRAINING MATERIALS

Each lesson in your participant manual begins with a page showing --

- the name of the lesson
- the learning goals of the lesson

- the objectives (that is, what you can expect to learn during the lesson)
- appendix items that go with the lesson
- "actions" you might perform during the lesson.

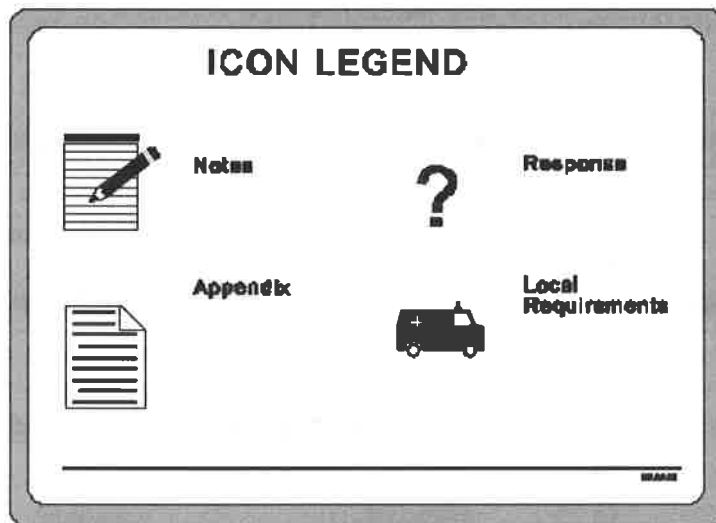

This icon shows where you will add local policies and procedures.

At the end of this course, you will have a useful reference that you can take back to the job and refer to whenever you have questions.

Appendixes/References/Glossary

Some very important information is included at the back of your participant manual. The appendixes include these items for your use:

- motor vehicle operation guidelines for our area
- hand signals for use by ground spotters
- sample checklists for the quick check and full check of the ambulance
- sample vehicle repair work requests
- a glossary that defines terms used in these training materials and on your job
- list of references used for this course
- additional references if you want further background

Your organization should have a reference library of materials for your refresher training and on-the-job training.

WHO THIS COURSE IS FOR

This course is designed for ALL ambulance operators whether you--

- are new hires or experienced operators who want refresher training

- work in large cities or small towns

- belong to paid professional or volunteer organizations

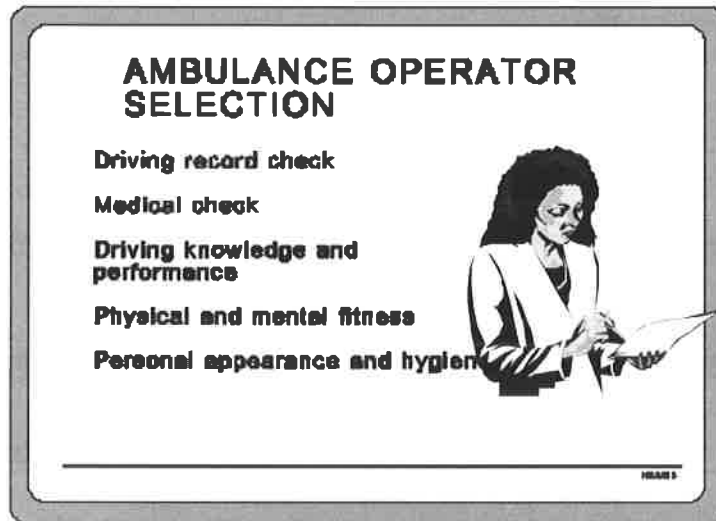

HOW YOU GOT TO BE AN AMBULANCE OPERATOR

You were selected based on your qualifications to perform the duties for an ambulance operator in response to emergency calls. Authorization of ambulance operators must always be based on Bona Fide Occupational Qualifications (BFOQ) for the task of ambulance operation.

Before you were hired, your overall qualifications were reviewed. This review may have included driving record checks, medical checks, and vocational tests.

A curriculum development group representing the major EMS professional organizations has assisted in developing this course. They support the

following recommendations for driving checks, medical check, driving knowledge and performance evaluation, and physical fitness.



Our organization has the following selection qualifications:



Four horizontal lines for listing selection qualifications.

Driving Checks

Driving record checks and license checks should be preconditions to hiring or acceptance into an EMS organization.

State Motor Vehicle Record Check

A review of state motor vehicle records for the previous three years should have been conducted when you were first hired.

This review should have been checked for any speeding, careless or reckless driving, driving under the influence of alcohol or other mind-altering substances, or moving violations.

Motor Vehicle Accident Check

Your driving record should have been checked for any accidents

you have had in the previous five years.



Our organization requires these driving record checks:



License Check

Your driver's license should have been checked to make sure that you are licensed and qualified to operate the class of vehicle you will be driving.



Our organization requires these licensing checks--



Medical Check

A licensed physician determines if someone is physically able to perform the job of ambulance operator under all conditions. The medical exam

should reveal no medical or physical condition which would prove detrimental to operating an ambulance.

The examination identifies drivers who may be impaired by--

- loss of consciousness
- cardiovascular disease
- neurological/neurovascular disorder
- mental illness
- substance abuse/dependency
- insulin-dependent diabetes
- rheumatic, arthritic, orthopedic, muscular, neuromuscular, or vascular disease which interferes with the ability to control and operate a motor vehicle

The presence of a medical condition alone may not indicate an impaired operator. However, it can identify an area to consider when determining a person's medical fitness to operate an ambulance.



Our organization requires these initial medical checks and physical qualifications:



Driving Knowledge and Performance

You should also pass this ambulance operator course written test and driving test. That should be followed by a period of on-the-job training to evaluate your performance under actual job conditions. Following successful completion of the written test, the driving test, the on-the-job evaluation, and any local requirements, your supervisor should consider you a qualified ambulance operator.



Our local guidelines and policy for testing are--



Operator Qualification

In addition to the initial driving and medical checks you may have taken to qualify as an ambulance operator, you should maintain your qualifications by--

- keeping your license up-to-date and valid

- reporting any violation you receive when driving your personal vehicle

- remaining physically and mentally fit

- participating in training when available

Licensing

An operator with an expired state driving license is no use to the organization. Remember to renew your license before the expiration date. Keep abreast of changes in licensing requirements.

Physical and Mental Fitness

Your physical and mental condition affects the daily performance of your job. You are expected to be mentally and physically fit for every run.

Your **physical fitness** may be affected by your health and the amount of rest you are getting. For example--

- If you have the flu, you may not be at your best and alert.
- A shoulder injury may affect your ability to maneuver your vehicle.

- Over-the-counter medications may make you sleepy.

- Lack of sleep can make your response time slower.

If you are not in good physical condition it is better not to drive.



Our organization's physical fitness policy includes--



Having a good attitude is the best influence on doing a good job.

Your **mental fitness** may be affected by a lack of concentration or the use of alcohol or drugs.

If you are worried about a sick family member, money problems, or problems concerning children, you may be distracted and not perform at your best. It is better not to drive until you are better able to concentrate.

You can be distracted when you are angry about something. If you are angry, you may lose patience and take risks you normally wouldn't consider. Calm down before driving.

It is illegal to drink and drive. Don't drink at all when you may have to drive.

Illegal drugs are never acceptable, under any circumstances, and should never be used while on or off duty.

Consider your physical and mental condition every time you go on a run to ensure your safety and the safety of your crew and patients.

Personal Appearance and Hygiene

While not exactly a part of physical and mental fitness, your physical appearance and hygiene have a lot to do with how well you perform your job duties.

A professional physical appearance builds confidence in patients and other civilians that you might need to direct. Your professional bearing will be a credit to your organization.

Secondly, your personal hygiene and patient handling precautions are required to prevent the spread of infection. If you get sick, you will not be of much use to your organization.

Professional appearance relates not only to your person but also to your equipment. Clean, properly stowed equipment makes your task--driving the ambulance and transporting patients--safer and easier, and makes the results more positive.

Participation in Training

After you have been selected to be an ambulance operator, your most important task is to improve your job performance at every opportunity. Training programs like this one are a part of that experience.

	<p>Often this is the beginning of several years of training. Many of you will be required to complete the EMT-BASIC within a certain time. Many of you already may be qualified EMTs.</p>
--	---

	<p>The ambulance crew should strive to become as qualified as possible within their organization. When possible, all crew members should be working to become paramedics operating advanced life support-equipped ambulances.</p>
--	---

**POINTS TO
REMEMBER**

Ambulance operators are selected based on their qualifications to perform the duties required of them.

A driving record check and license check is a precondition to hiring.

A medical evaluation should be required to determine physical ability to perform the job under all conditions.

You should pass this ambulance operator course written test and driving test, then pass the on-the-job driving evaluation.

You are expected to be mentally and physically fit for every run.





Your personal appearance and hygiene have a lot to do with how well you perform your job.

You're here because you have an important job to do, driving an ambulance, and this training course will offer you the training designed for all aspects of that job.

The training will be presented in the classroom, behind the wheel, and on the job. When you have successfully completed all three modules, you will be recommended to certification as an ambulance operator.

COURSE:	EMERGENCY VEHICLE OPERATOR COURSE (AMBULANCE): NATIONAL STANDARD CURRICULUM
MODULE A:	Ambulance Operation: The Basics
LESSON 2:	Legal Aspects of Ambulance Operation
COURSE GOAL:	To provide ambulance operators with the knowledge and skills to operate their vehicles so that their vehicle, equipment, crew, and patients will be delivered safely and efficiently and the safety of the public will be assured during all phases of the delivery of Emergency Medical Services (EMS) involving the ambulance
MODULE GOAL:	To provide ambulance operators with the knowledge and skills to safely and efficiently operate an ambulance in both nonemergency and emergency modes
LESSON GOAL:	To provide participants with knowledge of the federal, state, and local laws and of how to apply the laws when operating an ambulance
PERFORMANCE OBJECTIVE(S):	<ul style="list-style-type: none"> ● Identify types of laws that apply to ambulance operation ● Identify how specific laws apply to ambulance operation

PM APPENDIX:	Appendix A, Job Aid - Area Motor Vehicle Operation Guidelines
PARTICIPANT MATERIALS:	

ICON LEGEND			
			
Notes	Response	Appendix	Local Requirements

INTRODUCTION

As an ambulance operator, you are responsible for the safe and efficient transportation of your patients and crew. At the same time, you must look out for the safety of the public. The very nature of your job requires you to work with others during a time of crisis and with this comes certain risks. You need to be aware that at all times while performing your job, you are being held "legally accountable" for your actions.

DEFINING THE LAW

Types of Regulations

There are several types of regulations that tell how to conduct emergency vehicle operation. These regulations are for all types of emergency vehicles including ambulances.

Constitutional laws come from the U.S. Constitution. The Constitution guarantees the rights of the individual. These laws explain patients' rights before, during, and after transport.

Statutory laws come from legislative acts. Each state has various laws or statutes that tell how to operate emergency vehicles. The laws vary from state to state.

Ordinances are guidelines enacted by a governing municipal body or its agent. These guidelines usually include city or county codes.

Rules and regulations are guidelines enacted by an agency that have the force of law. The rules and regulations are intended to provide more information about statutory laws. These are often referred to as the

organizational policies and procedures or Standard Operating Procedures (SOP).

Understanding the Regulations

There are several things about emergency vehicle operation laws that you need to know. You need to know how the laws work and when you are exempt from doing what the law says to do.

With so many regulations telling how to operate emergency vehicles, you must know which law applies in a given situation. You may feel like there may be a conflict of policy about how you do your job. Here are some suggested guidelines for EMS ambulance operators:

All organizational policy should incorporate the principles of state laws, local ordinances, rules, and regulations into guidelines for the ambulance operator.

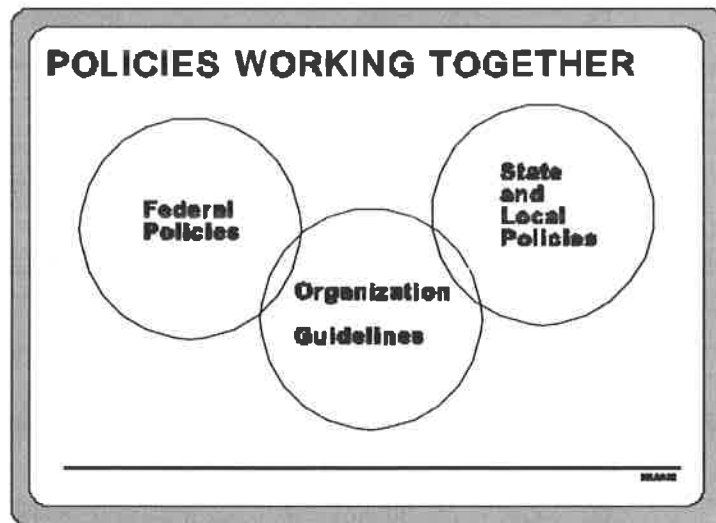

This means that all organizational policies and procedures should include and must not contradict federal, state, and local laws concerning the ambulance operation under all conditions. Your organization's policies may be formal or informal, but all policies should be in writing. This can provide protection from liability issues. As an operator, you must know your organization's policies.



Local policies include--



Four horizontal lines for writing, located in the third row of the table.

There are times when you will be exempt from certain guidelines listed in the regulations. As part of your job, you are required to make decisions concerning the operation of your vehicle. Good training provides you with the knowledge and ability to make appropriate decisions when faced with an emergency situation. Knowing ahead of time what the law says does not apply in the situation is important. Keep the following three principles in mind when approaching the idea of exemptions:

1. Ambulance operators are subject to all traffic regulations unless a specific exemption is made in the state or local statutes.
2. Exemptions are legal only in the emergency mode.
3. Even with an exemption, operators can be found criminally or civilly liable if involved in a crash.



What is meant by "specific exemption"?



Scenario

Below is a situation you may encounter as an ambulance operator. Read the scenario and answer the questions that follow.

Your state has a specific exemption for emergency vehicles proceeding through an intersection with a red signal light or stop sign. The exemption reads, "Emergency vehicles may proceed through an intersection with a red light signal or stop sign if the vehicle is brought to a complete stop, proper clearance is observed, and the vehicle proceeds through the intersection with caution."

During a run, you are following behind another emergency vehicle responding to an emergency call. You are approaching the intersection when you notice a red light. The other emergency vehicle stops, checks to see the intersection is clear, and then proceeds through the intersection. You then follow right behind the other vehicle through the light. Was your action within the law? Why?



INTERPRETING THE LAW

Law of Due Regard

All patients and crew members have the right to know that while being entrusted in your care, you are exercising "due regard" for their safety. If ever a crash should occur while you are operating an emergency vehicle, the courts will judge your actions according to this principle.

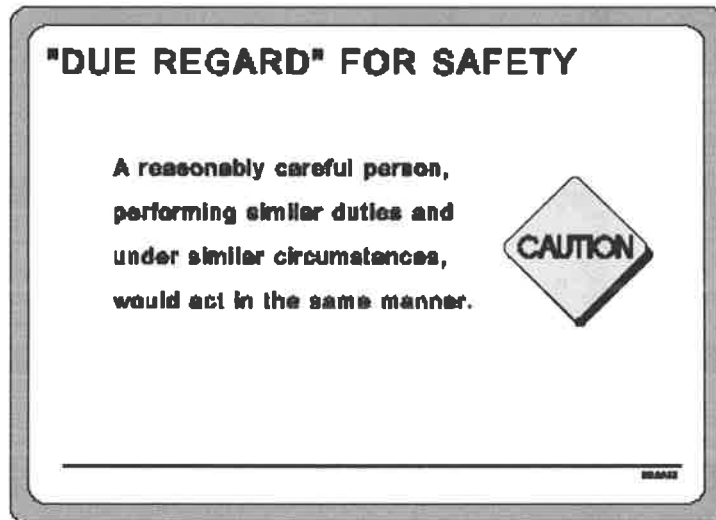

Deciding whether an ambulance operator has exercised "due regard" for the safety of others is always based on a specific set of circumstances. Certain rules, however, should act as guidelines for your actions. Always keep these points in mind when thinking about the Law of Due Regard and the safety of others.

Ask yourself these questions:

- Am I responding "like" others would in the same situation?
- Am I giving "enough notice" of my vehicle's approach to allow other motorists and pedestrians to clear a path and protect themselves?

[Notice is given by using appropriate signaling equipment (i.e., lights and siren) in accordance with statutes. Enough is difficult to define. If motorists have the windows up or the heater or air conditioner and radio on, it may take them a long time to respond.]

- Am I using the signaling equipment appropriately? Is it necessary to use it? Can motorists and pedestrians hear and see my signals?
- Am I exercising extreme caution? I must never travel at a speed that does not permit complete control of my vehicle.

True Emergency Situation

Others also will judge your liability in a situation by determining whether or not the situation involved a "true emergency."

"TRUE EMERGENCY" SITUATION

Involves high probability of death or serious injury to an individual and action by operator may reduce seriousness of the situation.



In some situations, others--not you--will decide whether or not a true emergency exists. However, even in emergency situations, you are still responsible for operating your vehicle in a safe manner.

Situations where others determine the "nature of the emergency" include--

- code system calls
- information from a dispatcher
- affiliated emergency service operator requests
- medical facility physician's decision

Hopefully, situations where you must decide what is a true emergency are

the exception rather than the rule. However, if faced with these situations, keep these points in mind.

Ask yourself these questions:

- Is there a high probability of death or serious injury to the patient?
- Will my actions reduce the seriousness of the incident?

Negligence

You may also be held liable in a court of law if you were in some way careless while performing your duties as an ambulance operator.

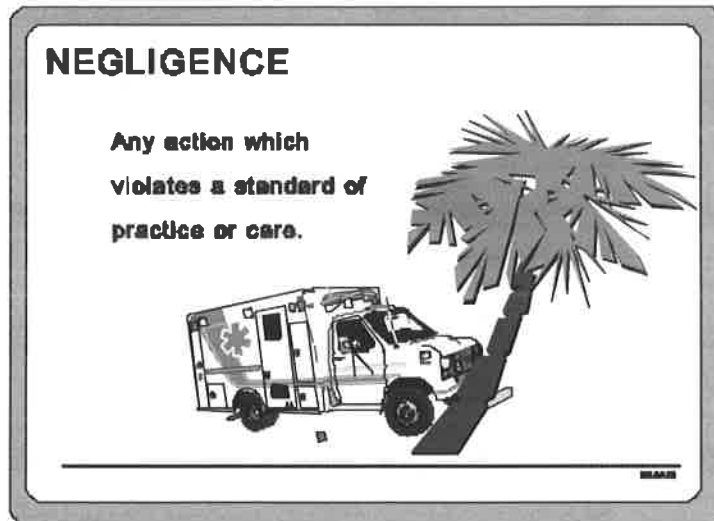

What this means is that as an operator something you SHOULD HAVE

done was not done or was done incorrectly. As a direct result, a person was injured or killed or property was damaged. No court can replace lives, but they can attempt to compensate the injured or their families with money.

In a lawsuit involving negligence, proving operator negligence is difficult. It must be proven that the negligence was willfully done. Certain facts must be established in the case. To avoid being caught in a negligence issue, keep the following in mind.

Ask yourself these questions:

- Do I have a "duty to act" towards the other person?
- What must I do to avoid a "breach of duty?" (For example, you must not fail to respond.)
- How can I avoid the other person suffering injury or loss because of my duty? (The actual cause of the other person's injury or loss must be a direct result of breach of duty, such as a violation of a traffic regulation.)



State and local policies on negligence include--



Abandonment

Another area that you need to be "legally" concerned with is abandonment.

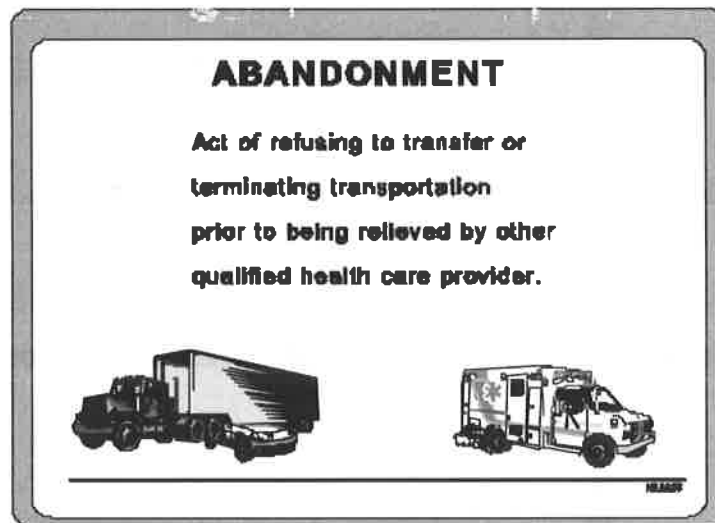

Once you begin to help someone having a medical emergency or someone who is injured, you have legally initiated a patient/provider contract. What this means is you must continue the responsibility for the patient's care until you have transported the patient to another medical provider of equal or higher qualifications.

This idea exists to make sure that the required care is completed. Also, it exists to avoid situations in which someone else does not stop to provide transportation thinking you are taking responsibility for the patient and will stay with the patient until another provider is reached.

Each state views abandonment differently. You need to know your states rule's and how you can be held liable regarding this issue. An instance that could be viewed as abandonment would be not responding to a call or failing to complete a run.



State and local policies on abandonment include--



Good Samaritan Provision

As part of the EMS team, you need to be aware that there are "Good Samaritan" provisions in the law applying to emergency operation and care.

GOOD SAMARITAN PROVISION

**Protects person who gives aid
at the scene of an emergency
from liability for additional
damage or injury.**



These provisions provide immunity to liability in cases in which you rendered care or were unable to render care. Most of the time the law will grant immunity from liability if the rescuer acts in good faith. Each state varies in regard to the issue of immunity. In some states, Good Samaritan provisions do not apply to volunteer ambulance crews. These states have determined that because the volunteers are acting as agents of an emergency response organization, the public can rightly expect a certain level of competence and training.



State and local Good Samaritan provisions include--



Patient Rights

As part of the EMS team, you need to know the rights of patients during a medical emergency transport. Patients have certain rights before, during, and after transport. You need to be aware of these rights so you do not become legally liable for violating the rights of the patient. Each state has specific laws regarding patient rights. Here are a few of these rights and what they mean.

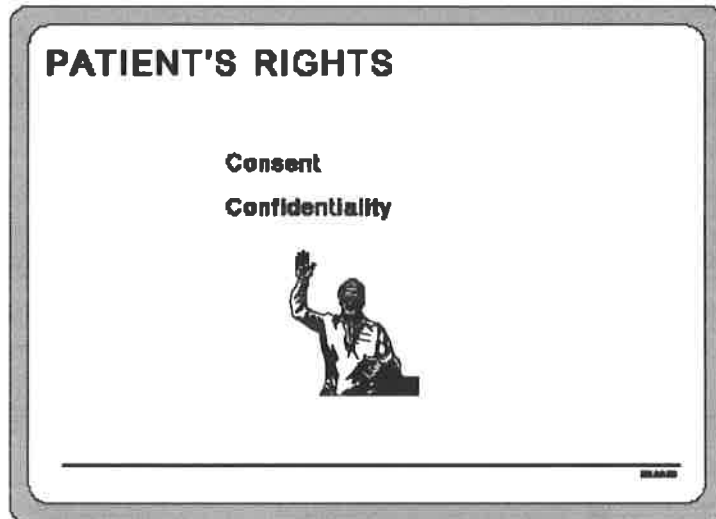

The consent to perform medical treatment is either actual consent, when patients are conscious and mentally competent, OR implied consent when the patients are unconscious or for other reasons unable to give you their actual consent.

Adults who are conscious and mentally competent have the **RIGHT TO REFUSE CARE!** This refusal may be either informed or implied.

When dealing with patient consent, here are a few guidelines you and the rest of the EMS team must follow.

- Respect the patient's right to refusal--do not restrain patients who have refused treatment, demand they be treated, or argue with them concerning the treatment.
- Have someone witness that your EMS team has offered care and the patient refused.
- Document that your EMS team offered care and the patient refused. Report immediately to dispatcher the refusal of care.

Even though many states do not have specific laws governing confidentiality and EMS care, you must as a team prevent the intentional invasion of a person's privacy. Confidentiality applies not only to cases of physical injury but also to cases involving possible infectious diseases, illnesses, and emotional and psychological emergencies. In some states, legal action can be brought against you if this patient right is violated.

When dealing with patient confidentiality, here are a few guidelines that you and the rest of the EMS team must follow.

- Do not speak to the press, your family, friends, or other members of the public about the service provided.
- Do not relate specifics about what a patient may have said, who the person was or was with, anything unusual about the patient's behavior, or any descriptions of personal appearance.



State and local policies regarding patient's rights include--



Other Legal Liability Issues

As part of the EMS team, you have other responsibilities during the medical emergency service operation that may carry legal implications if carried out in an inappropriate matter.

Other things your team must consider include--

- responsibility for passenger possessions
- accident reporting (must follow state guidelines)
- exceeding load capacity of vehicle weight restrictions
- failure to conduct/record ambulance inspections
- failure to provide training
- failure to maintain training records

- failure to maintain written records of safety meetings

Scenarios

Here are some situations you may encounter as an ambulance operator. Consider what was just discussed about operator liability and patient's rights. Read the scenarios and write down your response to the question(s) asked concerning the scenario.

Scenario 1: You are returning from a run when a car pulls up beside you while you are stopped at a traffic light. The individual informs you that a three-vehicle crash has just occurred on the nearby interstate. No other emergency vehicles are at the scene. The individual informs you that several of the victims are trapped in the cars. The severity of the injuries is unknown. Is this a true emergency situation? Why?



Scenario 2: Your ambulance is traveling the wrong way down a one-way street while enroute to a fire at a large apartment complex where people are reported injured. You are using all signaling equipment. Are you observing "due regard"? Why?



Scenario 3: A dispatcher reports that a man phoned requesting aid. The man is hysterical and the dispatcher can not determine the extent of the injuries. You respond in an emergency mode. In route, you receive a call from the dispatcher. He reports the man has calmed down and the man thinks his son may have broken his ankle; there is some pain and swelling. Is this a true emergency situation? Why?



IDENTIFYING SPECIFIC STATE AND LOCAL MOTOR VEHICLE OPERATION LAWS



Appendix A: Area Motor Vehicle Operation Guidelines

All states have statutes governing the operation of motor vehicles. It is important that you understand the statutes dealing with operating an ambulance. The "Area Motor Vehicle Operation Guidelines" handout outlines some specific state and local traffic regulations that apply to emergency vehicles.

**POINTS TO
REMEMBER**

In defining the law, we learned that--

- Σ federal, state, and local guidelines dictate Emergency Vehicle Operation
- Σ organizational requirements must incorporate and not contradict federal, state, or local requirements
- Σ there are certain situations where the ambulance operator may be exempt from the regulations--know the exemptions for your state

In interpreting the law, we learned that--





- Σ operators must exercise due regard for the safety of all patients and passengers
- Σ operators should not operate under emergency response conditions unless a true emergency exists
- Σ operators need to "think safety" to avoid negligence charges
- Σ operators have an obligation to continue providing care until relieved by other care providers once the operator begins the patient/provider relationship
- Σ operators need to know about the "Good Samaritan" provisions and how they affect them
- Σ patients have rights such as consent and confidentiality in medical emergency situations

By knowing specific state and local laws, you can protect yourself against liability situations and can act appropriately when faced with emergency medical situations in your area.

COURSE:	EMERGENCY VEHICLE OPERATOR COURSE (AMBULANCE): NATIONAL STANDARD CURRICULUM
MODULE A:	Ambulance Operation: The Basics
LESSON 3:	Communication and Reporting Roles and Responsibilities
COURSE GOAL:	To provide ambulance operators with the knowledge and skills to operate their vehicles so that their vehicle, equipment, crew, and patients will be delivered safely and efficiently and the safety of the public will be assured during all phases of the delivery of EMS involving the ambulance
MODULE GOAL:	To provide ambulance operators with the knowledge required to safely and efficiently operate an ambulance in both nonemergency and emergency modes
LESSON GOAL:	To provide participants with knowledge of the communication roles and responsibilities and protocols for receiving and sending messages
PERFORMANCE OBJECTIVE(S):	<ul style="list-style-type: none"> ● Identify communication roles and responsibilities ● Identify communication guidelines for receiving messages ● Identify communication guidelines for sending messages

PM APPENDIX:	Appendix B, Interpreting Hand Signals
---------------------	---------------------------------------

PARTICIPANT MATERIALS:	
-------------------------------	--

ICON LEGEND			
			
Notes	Response	Appendix	Local Requirements

INTRODUCTION

This lesson discusses your responsibilities for routine communication during a run.

Communication is an important part of your vehicle operation role. When you communicate, you tell others where you are and where you're going during a run. This helps dispatchers and other responders to do their jobs and take related actions.

COMMUNICATION RESPONSIBILITIES

You, the ambulance operator, and the entire EMS crew are responsible for routine communications at many points in a run.

Together you must operate as a team and all team members have tasks that they perform for every situation they are faced with.

Knowing these tasks and what to expect from each other will make your job easier.

Let's discuss when communication is required from the ambulance. The routine reporting points for the ambulance crew are--

- prerun
- when dispatched on a run
- upon scene arrival

- at the scene to give an update/overview/situation report
- before scene departure
- enroute to the medical facility
- after arriving at the medical facility
- when headed back to the station

Emergency Medical Technician (EMT) Communication Responsibility

The EMT in the passenger seat is responsible for communication when the operator is driving. The EMT communicates with the dispatcher, the medical facility, and other agencies.

During the most critical phase of the run--getting to the scene--it is important for the operator to focus on operating the ambulance. The EMT in the passenger seat does the communicating.

The EMT in the passenger seat should also write down the information you are receiving and direct you to the scene.

Unless it is absolutely necessary, do not communicate on the radio and operate the ambulance at the same time.

Dispatcher Responsibility

The dispatcher is another key member of the EMS communication team. The dispatcher coordinates all calls for an agency.

The dispatcher's specific responsibilities vary across locations. Often the dispatcher receives calls for emergency services and determines which crew will handle the call. The dispatcher will alert EMS and may alert additional assistance such as law enforcement, the fire department, heavy rescue, and harbor patrol. Some of these units may be from the same department.

The dispatcher may coordinate with other services responding to an incident.

Operator's Communication Responsibility

Your first responsibility is for safe and efficient operation of the vehicle.

Comprehensive Inspection and Maintenance Programs

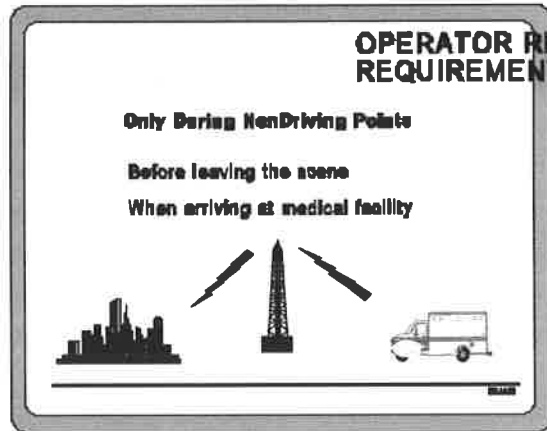

You, the operator, must report to the dispatcher at these points in your run:

- before leaving the scene for the medical facility
- after arriving at the medical facility

(Note to Remember: the EMT generally reports before leaving the station.)

Communicating to the dispatcher at these two points lets the dispatcher follow your movements and coordinate with others as necessary.

Report Before Leaving the Scene

When you are ready to leave the scene for the medical facility, you will call the dispatcher. Report that you are leaving and proceeding to the medical facility.

The EMT in the patient compartment will establish communication with the hospital, if necessary, to report on the patient's condition and talk with the physicians.

Reporting when you are ready to leave the scene enroute to the medical facility allows you to get information to plan the route you should take from the scene to that facility.

This is information that may not have been available from dispatch before you started your ambulance run because it is fast changing situation. For example, sometimes you will not know which medical facility you will drive to until your EMT diagnoses the medical situation at the scene.

Or if you are in an urban area, you will need information about fast-changing traffic congestion or incidents that could affect your drive from the scene to the medical facility. Also, during severe weather conditions, for example, you may need up-to-the-minute information about ice, snow, flooding, or other hazards on the roads you will drive to the medical facility.

You or your crew should report to dispatch any hazardous condition you find, such as traffic or route problems. This allows the dispatcher to describe up-to-the-minute route conditions for other emergency vehicles as needed.

Report When You Arrive at the Medical Facility

Reporting after you arrive at the medical facility lets the dispatcher know that your crew and vehicle will soon be ready to respond to another service

call.

Other Possible Reporting Situations

Tell the dispatcher whenever you are leaving the vehicle. This is important for those of you who do not carry a portable radio when away from your vehicle at a scene. Reporting when leaving the vehicle saves the dispatcher time searching for you.



Local guidelines require ambulance operators to report at these points during a run:





When do you, the operator, report to the dispatcher?



RECEIVING MESSAGES

Messages you receive may be for a run from the station or for another run after you have delivered a patient to the medical facility and before returning to the station.

Critical Items to Know for Every Run

The EMT will generally receive the initial service call from the dispatcher and give the information to you, the operator. All information should be recorded on log sheets by the receiving member of your crew.

Be sure you know the following information before starting a run.

<p>CRITICAL OPERATOR INFORMATION</p> <p>Operator Must Know For Every Run</p> <p>Address (location)</p> <p>Description of emergency</p> <hr/> <p style="text-align: right;"><small>EMT</small></p>

Know the Location

As the operator, the key information you must have is the address or location of the emergency.

You must have the specific location of the emergency to be able to plan your route. Get locator information such as street or highway, house number, nearest intersection and milepost markers. Or get exact directions. Directions may vary from "the Jackson farm" for rural situations to "15th and Main Streets, Northwest" for urban locations.

Know exactly where you are going before you depart.



What kinds of location information do you need in your area to get to any scene?



Four horizontal lines for writing, located in the right-hand cell of the fourth row of the table.

Description of the Emergency

You also will need a description of the emergency. This information will vary greatly based on local practices and who called the operations center. The information known before you arrive at the scene may even be incorrect, especially if given by someone under great stress from an incident.

It is even possible that your operations center may give only general information to discourage the tendency to take driving risks in life threatening situations.

However, some communities may give response priority as standard information. Sometimes the response priority is given in code.

If possible, you and your crew should know what is involved in the emergency. For example, are vehicles involved? What kind are they and how large are they? You should also know the type of injury, number of patients, and known hazards at the scene, such as downed power lines and/or hazardous materials.

Also, it will help you to know if other units are responding. Some organizations have a standard response that includes fire apparatus, police, and crash trucks. Other organizations will only have multiple responding units when conditions at the scene are known to require them.

If you know others are responding, you can anticipate other emergency vehicles on the route. They may be behind you. Or they may be approaching an intersection at the same time you are. While you will always be alert for all other vehicles on the road, it is helpful to know if other emergency vehicles are responding.



Locally there are guidelines for information that will be given for every ambulance run:



Four horizontal lines for writing, located in the seventh row of the table.

Review Receiving Messages

Before you leave on a run, you need to have the following information communicated from the dispatcher:

- address (location) and other identification to help you find the scene
- description of the emergency

Are there any questions about the communication you will receive?

SENDING MESSAGES

We've talked about when you need to report while on a run and what information you need to get before you depart on a run. Now we'll talk about how to report or communicate using the equipment in the ambulance you will drive.

The radio is the most common type of equipment in use.

Radio Communication Frequencies



You will need to know the frequencies for the various agencies you will communicate with on a variety of runs. There will usually be one frequency that will be the control frequency. All emergency vehicles can send and receive information from the dispatcher on that frequency.

The EMS, law enforcement agencies, and fire departments often have another frequency to communicate with their own organization.

If you respond to calls to assist other organizations in different cities or counties, those other cities and counties will probably have different frequencies. You will need to know how to communicate with them.

When you respond to an emergency involving several different organizations you need to know how to communicate with the organization that is in charge at the scene. If you don't have the correct frequencies, your operations center can relay information to you.

Some ambulances may have three or more radios that can receive and

transmit on different frequencies. Some of these radios will have a switch that will allow you to select a different frequency on the same radio. The ambulance can become a confusing place with several radios all going at the same time.

Communication Security

Most radio transmissions can be heard by anyone who has a radio with the emergency frequency. You must have a policy that protects individual's privacy.

Keeping security in mind, you must limit your transmission to only that which is necessary. Never joke about a situation.

Remember that anyone can listen to the conversation.

What to Say and How to Say It

COMPOSING MESSAGES

Plan

Identify person called, then calling unit

Be brief

Use plain English

Pronounce words clearly

Spell phonetically

Repeat directions



Before you pick up the microphone or other communication device, collect your thoughts and decide what you need to say. It has to be brief.

Your messages to the dispatcher need to include certain information and be presented the same way each time. Messages generally begin with the designation of the unit being called, followed by the designation of the calling unit. You must identify who you are calling, then identify your unit. You are not required to identify yourself by name.

For example, if you are unit 42 calling the dispatcher, you will begin "Dispatch, unit four two."

Brief message formats can be developed locally for routine reports. If you use the same format every time, you will be less likely to forget anything or give too much information.

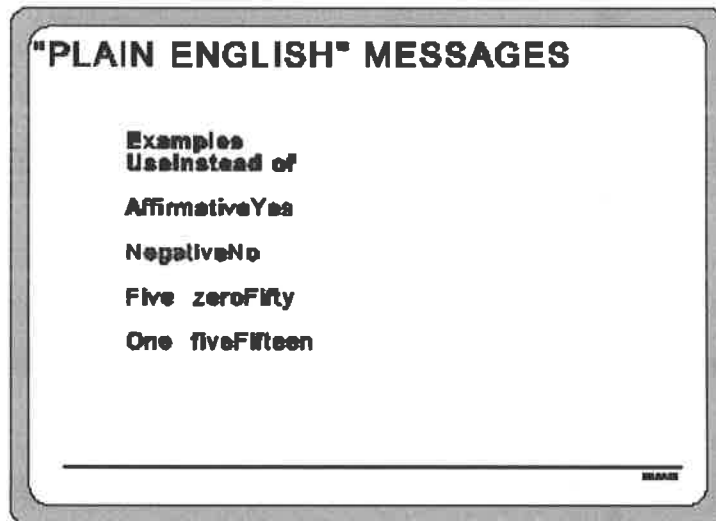

The standard language should be plain English, free of codes wherever

possible.

Choose words that can be easily understood. For example, "affirmative" is easier to understand than "yes."

Do not use filler words such as "Uh" and "well."

Give numbers in singular form, such as "five-oh" for fifty and "one five" for fifteen so that they cannot be confused. Route 495 is given as "route four nine five." Always pronounce the number "0" as zero.

Many organizations like to use ten codes to reduce air time and identify specific situations or events. However, codes can be misunderstood, especially if you are communicating with some other organization that doesn't use the codes. Numerous organizations are moving away from ten codes and are using plain language instead.

Plain language is less likely to cause confusion. Use codes only if they are a requirement of your organization and you are sure the person receiving your communication knows the codes.

Pronounce words clearly and crisply. Speak as clearly as possible and without emotion so you will be understood. Speaking crisply means saying words in full, like "going" instead of "goin'."

Phonetic Alphabet

It is often hard to understand what is being received or transmitted, particularly when reception is poor. For example, we know that similar street names, like "Henry" and Emery," cause confusion.

Your organization should pick one of the phonetic alphabets and use them when needed. The following is the standard phonetic alphabet adopted by the Department of Transportation--

A - ALFA

B - BRAVO

C - CHARLIE

D - DELTA

E - ECHO

F - FOXTROT

G - GOLF

H - HOTEL

I - INDIA

J - JULIETT

K - KILO

	L - LIMA
	M - MIKE
	N - NOVEMBER
	O - OSCAR
	P - PAPA
	Q - QUEBEC
	R - ROMEO
	S - SIERRA
	T - TANGO
	U - UNIFORM
	V - VICTOR
	W - WHISKEY
	X - X-RAY

Y - YANKEE

Z - ZULU

How do you use it? You use it when you are having trouble getting someone to understand or when you can't understand. For example, to spell "Smythe" Street say this:

"Smythe Street: Sierra Mike Yankee Tango Hotel Echo. Smythe."

Repeat all of the directions to be sure that you have them right.



What are some examples of names or words that can be easily misunderstood over a radio or telephone?



How to Use the Radio Equipment

BROADCASTING TECHNIQUES

Listen

Depress microphone key

Talk with mouth close to microphone

Clear frequency

These are rules to remember when using a radio:

- Listen to the frequency to be sure it is clear traffic. If others are talking, wait for them to sign off before using the frequency.
- Press the microphone transmit key for a half second before speaking. If you're too quick to begin talking, your first word or syllable may be cut off.
- Keep your mouth close to the microphone, no more than 1-1/2 inches away.
- Clear the frequency when you finish. The word "out" is a standard way to signal the end of a radio transmission. Example: Unit 43 out.

Review Sending Messages

Remember, when sending messages--

- plan your message
- identify unit being called, then your own unit
- use brief formats
- use plain English where possible
- pronounce words clearly
- spell names phonetically
- repeat all directions

When using a radio--

- listen for a clear frequency
- depress the key and hold
- keep your mouth close to microphone to speak
- clear the frequency



You use this kind of equipment in your locality--





This is how our local equipment is different from using a radio--



To send messages using our equipment, you need to do the following:



Practice Composing and Sending Messages

Review the following radio dialogue.

SCRIPT 1:

Operator: "Dispatch, Unit Four Two."
Dispatcher: "Unit Four Two, dispatch. Ready to copy."
Operator: "Unit Four Two on scene."
Dispatcher: "Copy Four Two."
Operator: "Four Two changing to hospital frequency."
Dispatcher: "Copy Four Two. Out"



What was done right in that demonstration?





What was wrong in that demonstration?



SCRIPT 2:

Operator: "This is Unit four two calling the dispatcher. Come in, dispatcher."
Dispatcher: "Unit four two, this is your dispatcher. Ready to copy."
Operator: "Unit four two is on the scene at Henry Street and Fourth Avenue."
Dispatcher: "Copy four two."
Operator: "This is Unit four two changing to hospital frequency."
Dispatcher: "Copy four two. Out."



What was right with this demonstration?



What was wrong with that demonstration?



INTERPRETING HAND SIGNALS



Appendix B: Interpreting Hand Signals

Another kind of communication that an ambulance operator must understand is the method of signaling that a ground guide will do. Turn to Appendix B for a description of recommended hand signals that should be adopted by you and your crew who serve as your ground guides for backing and other driving situations. Your organization should adopt a system of hand signals such as this.

SUMMARY

Your first responsibility is operating the ambulance. The EMT in the passenger seat communicates when you are driving.

The dispatcher coordinates calls for an agency. Dispatcher's specific responsibilities vary.

The operator usually communicates with the dispatcher at only these two points in your ambulance run:

- before leaving the scene for the medical facility
- after arriving at the medical facility

When beginning a run you must have the address or location of the emergency and a description of the emergency.

You should keep in your ambulance at all times an up-to-date list of radio frequencies for your locality.

Limit your radio transmission to only that which is necessary. Anyone can listen to your conversation.

To send a message--

- plan messages before you talk
- identify the person called and the calling unit
- be brief
- use plain English
- pronounce words clearly
- spell confusing names phonetically
- repeat directions

When using radio equipment--

- listen
- depress microphone key
- talk with mouth close to microphone
- clear the frequency

Learn to recognize standard hand signals from your ground guide.

**POINTS TO
REMEMBER**

Your first responsibility is operating the ambulance. The EMT in the passenger seat communicates when you are driving.

The dispatcher coordinates calls for an agency. Dispatcher's specific responsibilities vary.

The operator usually communicates with the dispatcher at only these two points in your ambulance run--

- before leaving the scene for the medical facility
- after arriving at the medical facility

When beginning a run you must have the address or location of the emergency and a description of the emergency.

You should keep in your ambulance at all times an up-to-date list of radio frequencies for your locality.

Limit your radio transmission to only that which is necessary. Anyone can listen to your conversation for the price of a radio.

To send a message--

- plan messages before you talk
- identify the person called and the calling unit
- be brief
- use plain English
- pronounce words clearly
- spell confusing names phonetically
- repeat directions





When using radio equipment--

- listen
- depress microphone key
- talk with mouth close to microphone
- clear the frequency

Learn to recognize standard hand signals from your ground guide.

COURSE:	EMERGENCY VEHICLE OPERATOR COURSE (AMBULANCE): NATIONAL STANDARD CURRICULUM
MODULE A:	Ambulance Operation: The Basics
LESSON 4:	Ambulance Types and Operation
COURSE GOAL:	To provide ambulance operators with knowledge and skills to operate their vehicles so that their vehicle, equipment, crew, and patients will be delivered safely and efficiently and the safety of the public will be assured during all phases of the delivery of the Emergency Medical Services (EMS) involving the ambulance
MODULE GOAL:	To provide ambulance operators with the knowledge required to safely and efficiently operate an ambulance in both non-emergency and emergency modes
LESSON GOAL:	To provide participants with knowledge of ambulance types, weight restrictions, and operation
PERFORMANCE OBJECTIVE(S):	<ul style="list-style-type: none"> Σ Identify the types of ambulances Σ Identify how size and weight affects the operation and control of an ambulance
PM APPENDIX:	

PARTICIPANT MATERIALS:	
-------------------------------	--

ICON LEGEND			
			
Notes	Response	Appendix	Local Requirements

INTRODUCTION

Ambulance types vary according to location. This lesson gives a brief overview of the different ambulance types, general operating guidelines, and weight restrictions.

AMBULANCE TYPES

The KKK-A-1822C Federal Specification standards, published by the General Services Administration (GSA), recognize three types of ambulances--Type I, Type II, and Type III.

The "Star of Life" emblem may be displayed on the ambulance when the manufacturer certifies to the purchaser that the ambulance, it's components and equipment meet or exceed the tests in the KKK specification. This emblem certifies that the ambulance meets minimum specifications and passed certain tests, as well as design, performance, equipment, and appearance requirements.

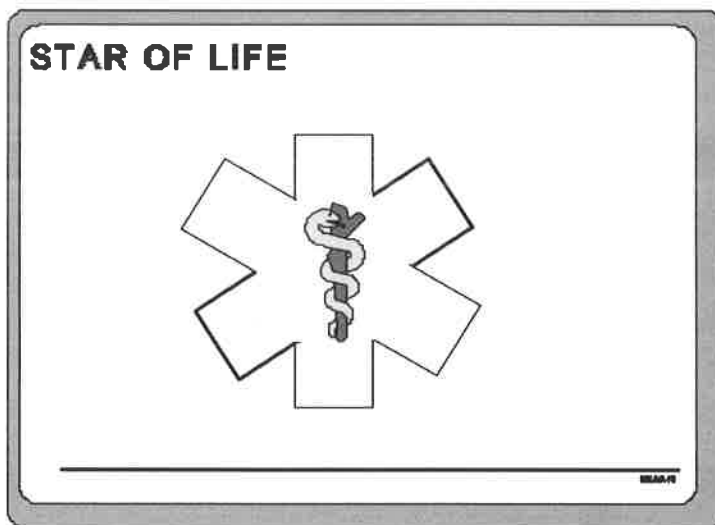

In this lesson we will only discuss the body types, service capability, classes, and weight restrictions of these three types of ambulances.

Type I Ambulance

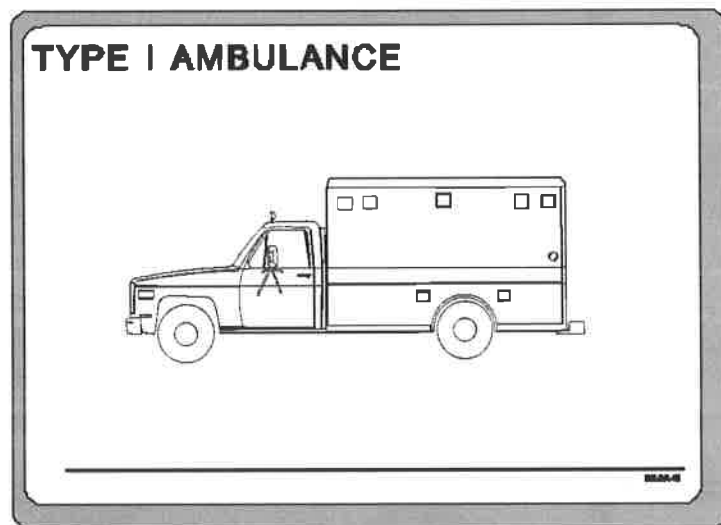

Body type: Conventional Truck, Cab-Chassis with Modular Body Ambulance

Service Capacity: Basic Life Support (BLS) or Advanced Life Support (ALS)

Classes: Class 1 - Two-Rear-Wheel Drive or Class 2 - Four-Wheel Drive

Type II Ambulance

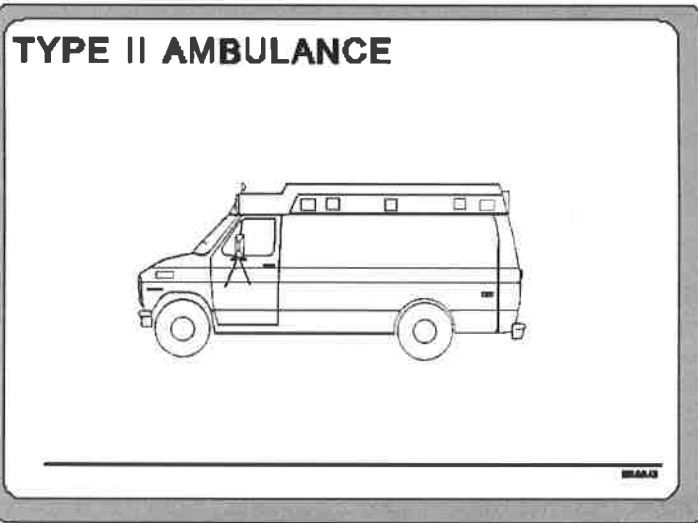

Body type: Standard Van, Integral Cab-Body Ambulance

Service Capacity: Basic Life Support (BLS) or
Limited Advanced Life Support (ALS)

Classes: Class 1 - Two-Rear-Wheel Drive or
Class 2 - Four-Wheel Drive

Type III Ambulance

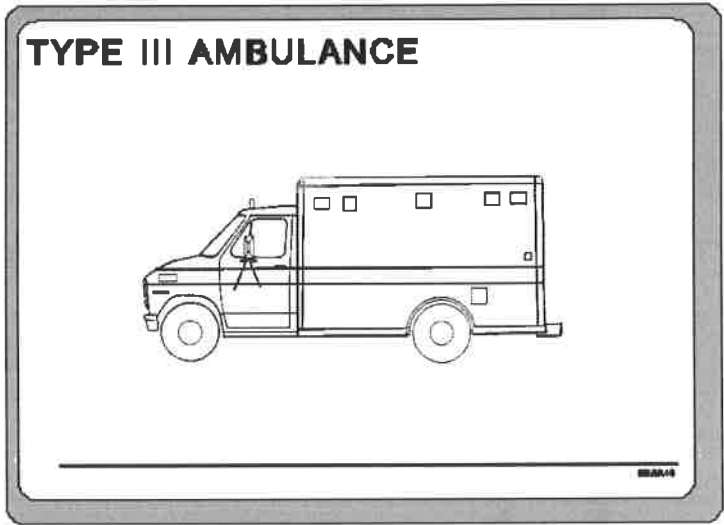

Body type: Cutaway Van, Cab-Chassis with Integral or Containerized Modular Body Ambulance

Service Capacity: Basic Life Support (BLS) or Advanced Life Support (ALS)

Classes: Class 1 - Two-Rear-Wheel Drive or Class 2 - Four-Wheel Drive



Your organization uses the following type(s) of ambulances:



Four horizontal lines for writing the organization's ambulance types.

If you usually operate the same type of ambulance, you will get to know all of the operating equipment and how to use it in a variety of situations.

If you might be assigned to drive a type of ambulance you have never driven before, have your supervisor (or another qualified operator) give you an orientation to the new ambulance. You should have an opportunity to PRACTICE driving a new ambulance type and pass a written and performance test before you operate the ambulance.

Weight Restrictions

No matter what type of ambulance you drive, you must know your ambulance's weight restrictions in order to operate safely during all driving conditions.



When an ambulance arrives at your facility from the manufacturer it is labeled with a gross weight. You can usually find this information on the weight/payload certification sticker mounted on the body in a conspicuous location.



Payload capacity information is found in:



The payload capacity is used to determine--after considering equipment weight--how many crew members and patients it is safe to transport. The national standard for determining the weight of one person is 175 pounds per person.



With a crew of _____
our ambulances can safely carry _____ pounds
or _____ patients.



With a crew of _____
our ambulances can safely carry _____ pounds
or _____ patients.

Each ambulance organization should have a current loading plan in the ambulance log book. The loading plan should have the current payload, i.e., how much the ambulance can carry.

The loading plan should distribute the weight of the patient, crew, and equipment evenly. Too much weight in one location can change the handling characteristics of the ambulance.

As equipment is added to the ambulance, the new weight should be figured and the loading plan updated. Remember that for each piece of equipment added, the patient and passenger weight that can be safely carried decreases.

Knowing how many people you can carry and keeping an accurate loading plan will help you decide how to load your ambulance.

Just because you have seats available does not mean that you can load a patient or passenger into each one.

And just because your ambulance is designed to carry only two patients does not mean that you leave a third patient at a crash scene rather than loading them.

Two children might actually equal one adult person. Remember that an average weight of 175 pounds is used to calculate passenger and patient capacity.

The most important thing for you to know and remember about ambulance types and weight restrictions is **HOW MANY PATIENTS AND PASSENGERS YOU CAN SAFELY TRANSPORT.**

Your good judgment is needed. If you are the only ambulance at a crash scene, you may have to load more weight than ideally recommended. If you know that your ambulance is overweight, you can adjust your driving to accommodate the situation.

OPERATION

Besides the limitations put on you by the weight restrictions of your ambulance, there is a difference between driving a car and driving an ambulance. These differences make an ambulance harder to drive than a car. You need to know these differences and understand how they affect your ability to operate the ambulance safely.

Size

An ambulance is larger than a standard car. It is wider, longer, and taller which makes it harder to maneuver. The ambulance's width and length affects turning; its height means you must be aware of height clearances (for example, parking garages, bridges or overpasses, covered entrances).

Differences Affect Maneuvers



What other problems can the size of your ambulance cause?



Four horizontal lines for writing a response to the question above.



In your area, what are some specific places where we have to exercise extra caution because of the size of our ambulances?



Four horizontal lines for writing a response to the question above.

Weight

An ambulance may weigh more than a car. This is important to remember because it takes longer to accelerate and brake. When pulling out into traffic, for example, an ambulance will not move out as quickly as a car. When braking, you will need more room to come to a complete stop.

Equipment Affect Accelerating
and Braking

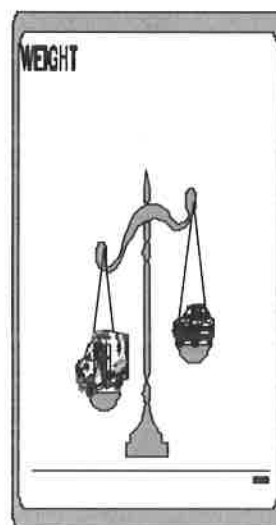

Visibility

Because of an ambulance's size and style, there are blind spots that can block your view of objects and vehicles around you. You must rely heavily on your side view mirrors since a rear view mirror is not always available.

Even when a rear view mirror is provided, it may not be as usable as you would like. Rear view mirrors are mostly useless even in Type II ambulances. Activities in the patient compartment may block your view out of the back of the ambulance. Plan on using your side mirrors only.

This is why you should ALWAYS use a ground guide when backing up.



What are some other situations when your vision might be blocked? What can you do about it?



**POINTS TO
REMEMBER**

There are three KKK-recognized types of ambulances--Type I, Type II, and Type III.





Weight restrictions of the ambulance type determines the maximum number of crew and patients you can safely carry.

All ambulance types require extra caution when driving because of their size, weight, and visibility.

COURSE:	EMERGENCY VEHICLE OPERATOR COURSE (AMBULANCE): NATIONAL STANDARD CURRICULUM
MODULE A:	Ambulance Operation: The Basics
LESSON 5:	Vehicle Inspection, Maintenance, and Repair
COURSE GOAL:	To provide ambulance operators with the knowledge and skills to operate their vehicles so that their vehicle, equipment, crew, and patients will be delivered safely and efficiently and the safety of the public will be assured during all phases of the delivery of the Emergency Medical Services (EMS) involving the ambulance
MODULE GOAL:	To provide ambulance operators with the knowledge required to safely and efficiently operate an ambulance in both nonemergency and emergency modes
LESSON GOAL:	To provide participants with knowledge of ambulance operator responsibilities for vehicle inspections and maintenance
PERFORMANCE OBJECTIVE(S):	<ul style="list-style-type: none">● Select from a list the operator's responsibilities for vehicle inspection● Select from a list the operator's responsibilities for vehicle maintenance and repair

PM APPENDIX:	D: Sample Checklist: Full Check E: Sample Work Request
---------------------	---

PARTICIPANT MATERIALS:	
-------------------------------	--

ICON LEGEND			
			
Notes	Response	Appendix	Local Requirements

INTRODUCTION

Normal ambulance operation puts great demands on the vehicle. As the operator, you may be held legally responsible for any **preventable** mechanical failures that lead to accidents or loss of life.

When you place a vehicle in service by taking it out on a run, you are assuming **personal responsibility** for its operating condition.

How can you ensure that your ambulance is in a safe operating condition?

ENSURE SAFE OPERATING CONDITION

Visually inspect.

**Check that scheduled maintenance
has been performed.**

Check that all repairs have been made.

You ensure the safe operating condition of your vehicle by--

- inspecting the vehicle according to established procedures

- checking that all scheduled maintenance has been performed

- checking that all needed repairs have been made

If a vehicle is **NOT** in a safe operating condition, you, as the operator have the responsibility to take the vehicle out of service until the problems have been fixed.

MAJOR MECHANICAL SYSTEMS

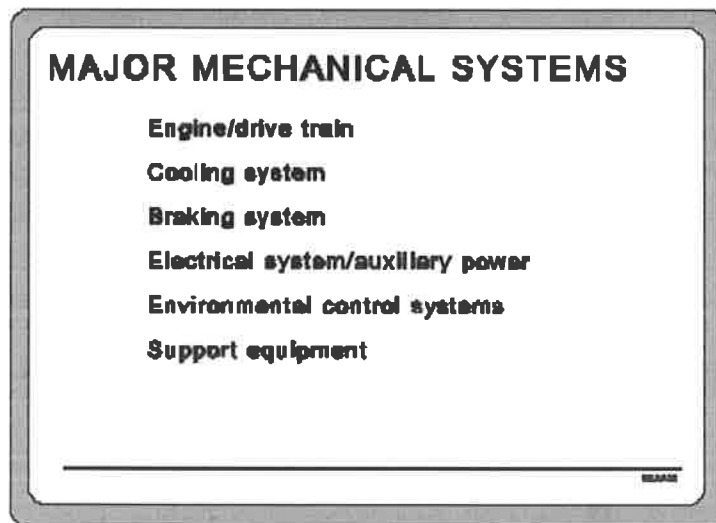

Engine/Drive Train

The weight of the vehicle and its installed auxiliary systems require most ambulances to have a large engine, either diesel or gasoline powered. To provide the smoothest ride possible, these powerplants are most often

connected to automatic transmissions.



For our discussions, we will use a _____ engine and _____ transmission.

Cooling System

It is critical that you check the fluid level of the cooling system every day, especially in hot weather. Remember to follow the correct procedures for your vehicle. Severe burns can be the result of doing this check wrong.

Braking System

There are two types of brake systems in use today. The older, drum-type brakes are still used extensively in trucks. Many of the newer vehicles use the more reliable disc brakes. These two types are often used together, with the disc brakes installed on the front wheels, where most of the braking effort occurs, and drum brakes on the rear. Anti-lock braking systems are now available from some truck manufacturers and are especially efficient on snow and ice.



Brake systems on our vehicles are--



Electrical System/Auxiliary Power

The electrical system is a vital component of your ambulance. These heavy-duty systems require careful attention and monitoring to ensure that they retain peak efficiency.

To provide electrical power while parked, without drawing from the ambulance's battery(ies), many units have auxiliary power systems installed. An auxiliary power system is a small, engine-powered generator, such as a portable generator. It is independent of the ambulance's electrical system and is used during heavy electrical load conditions. Auxiliary power systems are normally mounted in the rear of the ambulance and are used to power the lights and basic life support equipment while parked.

Most ambulances are equipped with a DC to AC inverter to provide AC power. The inverter provides a constant 115 volt AC power source for onboard AC systems. The patient compartment has AC outlets for using AC systems. Some of your lighting is also powered by AC. The crew will select AC power when needed to supply certain systems in the ambulance. When they activate the inverter a red light indicator will be illuminated. Your supervisor will cover the operation of the inverter when you get your orientation on the ambulance that you will be driving. For more information about inverters and AC power supplies, check with your maintenance supervisor and consult the General Services Administration Federal Specification for Ambulances, KKK-A-1822C.



Your vehicles have (do not have) auxiliary power systems.



Environmental Control Systems

Environmental control systems are the heating and air conditioning systems.

Support Equipment

All ambulances have similar basic medical support equipment installed by the manufacturer. Each organization then customizes its vehicles with additional equipment, often outfitting vehicles to meet specific requirements. So, not all vehicles will carry the same equipment.

When the typical ambulance leaves the factory, it is designed to carry a driver and an EMT at 175 lbs. each, two patients at 175 lbs. each, and the following medical support equipment:

- main and portable oxygen bottles
- stretchers, cots, and patient handling equipment
- portable, removable medical devices
- durable and disposable medical items
- optional vehicle equipment such as battery charger, inverter, or auxiliary power unit
- communications equipment
- extrication and rescue equipment



In addition to this equipment, carry the following equipment in your vehicles:



As the operator, you will be responsible for inspecting your vehicle and for properly operating its mechanical systems. You may also be responsible for providing routine servicing and preventive maintenance for each system and its components.



For other maintenance and repairs, you will--



VEHICLE INSPECTION

SYSTEMATIC VEHICLE INSPECTIONS

- Find and report problems.
- Track preventive maintenance.
- Document vehicle condition.

By conducting regular, systematic vehicle inspections, you are able to--

- find and report problems that need to be fixed
- keep track of preventive maintenance requirements
- document the overall condition of the vehicle

Inspection Standards

The ASTM Standard Guide for Training Emergency Medical Services Ambulance Operators inspection standards were used to develop the inspection procedures presented in this lesson and may be adopted in whole or in part by your organization. These standards provide a **minimum acceptable level** of vehicle inspection.

Inspection Methodology

To ensure that vehicle inspections are consistent, thorough, and accurate, each EMS organization develops specific vehicle inspection procedures and checklists to meet its needs. The completed checklists are then kept on file and are used to document the condition of the vehicles.

Importance of Maintaining Records

If an emergency vehicle is involved in a crash, and there is the possibility that a mechanical malfunction was the cause, the courts would be very interested in reviewing the maintenance records of the ambulance. If the operating organization knew in advance of the malfunction and continued to operate the vehicle, it may be found negligent and held liable for all damages resulting from the crash.

Maintenance organizations must be able to document in writing the servicing, maintenance, and repair of their vehicles and equipment. A good general guideline for documenting inspections and maintenance actions is: "If it's not in writing, it did not happen."

Inspection Schedule

The schedule below is a recommendation and may be different from the one used in your organization. Whether you inspect by number of runs per week, by hours of operation, or by specific days of the week, the important thing is that you inspect according to a specific schedule and that you strictly stick to that schedule.

RECOMMENDED INSPECTION SCHEDULE	
RUNS PER FULL WEEK	CHECKQUICK CHECK
31	Every 96 hours
29	Every 72 hours
47	Every 48 hours
60	Every 24 hours
58	Every 24 hours

An organization's inspection schedule is determined by a number of factors, including vehicle age and mileage, insurance requirements, and past experience.



Our organization's inspection schedule is--





How are our inspection procedures different from the recommended procedures?



Inspection Types

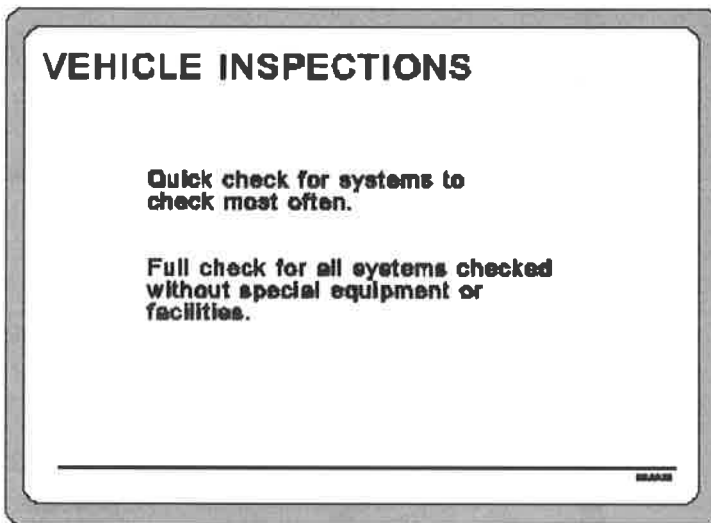

There are two types of vehicle inspections recommended for ambulances:

- The **Quick Check** covers those systems that should be checked most often.
- The **Full Check** covers all vehicle systems that can be checked without special equipment or facilities.

QUICK CHECK

Checklist



A Sample Checklist for the Quick Check can be found in Appendix C.

Appendix C

Sample Checklist: Quick Check

SAMPLE CHECKLIST

UNIT NUMBER: _____ STATION: _____ DATE: _____ TIME: _____

INSPECTION: _____

INSPECTOR: _____

Item	Check	Inspection	OK	Needs Attention	Block
Engine Oil	Level				
Engine Oil	Color				
Engine Oil	Leaks				
Engine Oil	Pressure				
Engine Oil	Temperature				
Engine Oil	Level				
Engine Oil	Color				
Engine Oil	Leaks				
Engine Oil	Pressure				
Engine Oil	Temperature				

The first things you should fill out are the unit or ambulance number, the station where it is located, and the date and time of the inspection.

When you conduct the inspection, you should--

- inspect each item and place a check mark in the column labelled **OK** if there are no problems. By checking off an item as OK, you verify that **you** (1) inspected it and, (2) found no problems with it.

- fix any problems found, if you are capable and authorized to do so, and document that you did so in the Work Completed block, **OR** file a work request for the problem(s) found

Note that any starred (*) problems must be fixed before the vehicle is placed in service.

- decide whether or not to place the vehicle in service and document your decision by circling the appropriate word in the printed statement above your signature



- sign and date the checklist

Checklist Format

Ambulance Diagram

Inspection Sequence

The inspection is divided into specific areas of the ambulance. There are several items to inspect in each area. The sequence is designed so that you inspect all the listed items in one area before moving clockwise around the vehicle to the next area. Because all the items to be inspected are listed by area, there is less chance that you will forget an item that was called out in a previous area.

	Area Rows
	These are the areas that you will check and in the recommended sequence.
	Items Column
	These are the items that you will check in each area.
	Check Column
	For each item listed, this is what you are to check.
	Problem Column
	In this area, briefly describe any problems discovered. If you think the problem makes the vehicle unserviceable, put a star (*) to the left of the description of the problem. These starred items (*) must be corrected before placing the vehicle in service.
	Our organization has (does not have) such a list. It is located--
	<hr/> <hr/> <hr/> <hr/>

A single problem without a star may not keep you from placing the vehicle in service.

Example 1: Suppose a vehicle you have inspected has one cracked turn signal lens and a slow oil leak. Depending on organization guidelines and other circumstances, you may or may not place the vehicle in service. Before making your decision, you may want to talk to a supervisor and/or maintenance.



Our organization would handle this example by--



Example 2: One organization might let a vehicle go on a run with a broken windshield wiper on a clear day; another organization might take the vehicle out of service. In either case, the problem should be documented and the repairs made as soon as possible.



Our organization would handle this example by--



OK Column

Check here if there are no problems in the area inspected OR if you found a problem and have fixed the problem yourself.

Work Request Column

If you find a problem and are not able or are not authorized to fix it yourself, file a work request with your maintenance organization.

Work Completed/Other Remarks Column

Organization policies and procedures will tell you which specific items you are authorized to service or repair yourself. Note all work you did and any other information about the problem.

Preparation

To prepare for performing the Quick Check, you need to do three things:

- Arrange for another crew member to help you check the lights.

- Place wheel chocks where you can quickly retrieve them if required.
- Get a blank checklist and fill out the administrative information.

Inspection Sequence

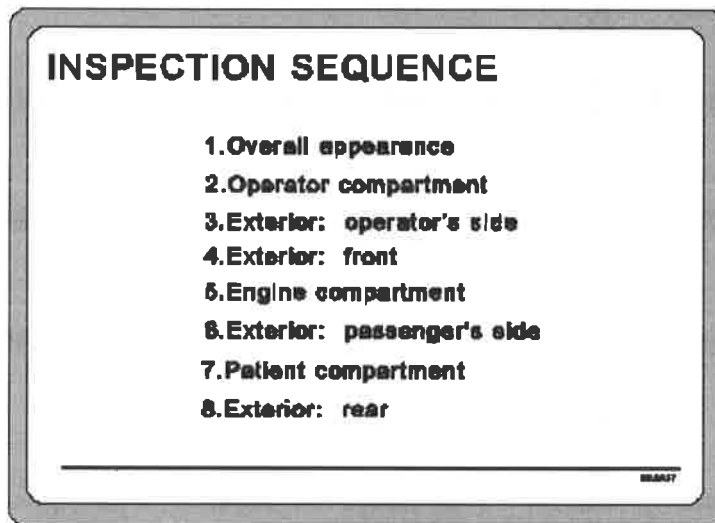

There are eight specific areas to be checked during the quick check inspection. They are--

- 1) Overall Appearance
- 2) Operator Compartment
- 3) Exterior: Operator's Side

	4) Exterior: Front
	5) Engine Compartment
	6) Exterior: Passenger's Side
	7) Patient Compartment
	8) Exterior: Rear
	1) Overall Appearance
	<ul style="list-style-type: none">• Check vehicle cleanliness.
	Your overall appearance to the public as a professional organization is enhanced by a clean, well-maintained vehicle.
	<ul style="list-style-type: none">• Check general vehicle condition.
	Is the vehicle sitting level?
	Are there any puddles or other signs of visible fluid leaks?
	Are there any signs of new, unreported body damage?

2) Operator Compartment

- Check the vehicle log.

The most recently completed Full Check and Quick Check checklists should be in the log, along with blank copies of the run report and a complete inventory list of installed equipment.

- Check for stowage of items.
- Be sure switches for lights and communication equipment are in the "off" position.
- Adjust the seat, seat belt, and side view mirrors.
- Release the hood latch.
- Turn the key to the ON position and check the fuel gauge.

Routine refueling should occur when the fuel level is between 1/2 and 3/4 empty. Follow your organization's procedures for refueling.



Your organization uses the following refueling procedures:



3) Exterior Walk-around: Operator's Side

- Check left outside mirror bracket for general condition.
- Check left side window for general condition.
- Check left side of windshield, left wiper for general condition.
- Check the left front wheel and tire for general condition.
- Check the tire for a properly inflated appearance, but do not check tire pressure.
- Check left front fender for general condition.

4) Exterior Walk-around: Front

- Inspect front of vehicle and grill for general condition.

Remove any obstructions to the grill, radiator, or lights.
- Visually check condition of headlights and turn signals.

- Visually check condition of emergency lights from the front.

5) Engine Compartment

- Open hood and visually check engine for signs of leaks.
- Visually check condition of belts.
- Visually check condition of battery(ies).
- Check levels of engine oil, windshield washer fluid, and cooling system.

Check coolant level at overflow reservoir; do not remove radiator cap to check.

Replenish fluids according to local organization's requirements.



Always replenish the engine oil when it is one quart low. In addition, our fluid replenishment requirements are--



- Close the hood and ensure that it is latched.

6) Exterior Walk-around: Passenger's Side

- Check right front fender for general condition.
- Check the right front wheel and tire for general condition.
- Check the tire for a properly inflated appearance, but do not check tire pressure.
- Check right side of windshield, right wiper for general condition.
- Check right side window for general condition.
- Check right outside mirror bracket for general condition.
- Check right rear fender for general condition.
- Check the right rear wheel and tire for general condition.
- Check the tire for a properly inflated appearance, but do not check tire pressure.

7) Patient Compartment

- Open rear doors and visually check general condition of patient compartment.

Check that all equipment is properly secured.

Verify that no new equipment that may change vehicle weight has been added to patient compartment.

- Close rear doors and ensure that they are properly latched.

8) Exterior Walk-around: Rear

- Visually check the condition of emergency lights from the rear.
- Visually check the condition of rear lights and turn signals.
- Visually check the condition of external flood lights, if installed.
- Check the left rear fender for general condition.
- Check the left rear wheel and tire for general condition.
- Check the tire for a properly inflated appearance, but do not check tire pressure.

When you finish the check, decide whether or not to place the vehicle into service and sign and date the form. Place your completed checklist into the vehicle log.

NOTE: If your organization requires an operational check of the communications and emergency warning equipment, perform those checks after completing the visual inspection.

To conduct operational checks--

- start the vehicle and drive it outdoors
- check the communications equipment, following local procedures
- operate and have the other crew member check the emergency lights
- check the siren, following local procedures
- secure the communications and emergency equipment and return the vehicle to its parking space



Our organization requires (does not require) operational checks of the communications and emergency warning equipment. The local procedures are--



FULL CHECK



A Sample Checklist for the Full Check can be found in Appendix D.

Appendix D

Sample Checklist:

Full Check

The same headings are used for both the Full and Quick Checks. The Full Check includes additional items and should be adapted to meet each organization's requirements.

The Full Check also follows the same basic clockwise rotation to ensure a systematic inspection.



Your organization requires that you perform the following vehicle maintenance checks before you place a vehicle in service-





How is your organization's checklist different from the recommended checklist for the Quick/Full Check?



Negligence Related to Inspection

An operator might be judged to be negligent with regard to vehicle inspection for two main reasons:

OPERATOR NEGLIGENCE

Failing to inspect a vehicle thoroughly in accordance with organization's requirements.

Knowingly operating an unsafe vehicle.

EMERSON

- failing to inspect a vehicle thoroughly according to the organization's requirements

- knowingly operating a vehicle with a problem that should have caused it to be taken out of service

Negligence: Case study

The following is an example of negligence related to vehicle inspection.

Background: A crew was taking a patient to a hospital in the next county. The ambulance maintenance log, which contains information about previous inspections and work requested and completed, was kept in a room upstairs from the vehicle. The crew was in a hurry, so they did not review the log before they left, contrary to the organization's procedures. They also did not perform a Quick Check.

Midway through the trip, the oil pressure warning light came on, and the engine temperature rose. The crew pulled over and called for a replacement vehicle.

Investigation: The follow-up inquiry included a review of the ambulance maintenance log. The two most recent vehicle checks each noted a slow oil leak. The maintenance log contained a note to the operator to check the oil level before each trip. The log showed that repairs were scheduled for the following Monday, when the regular mechanic returned from vacation.

How might the operator be judged negligent in this situation?





How might the organization also be found at fault?



Refusing to Drive an Unsafe Vehicle

You should never operate a vehicle that is not in safe operating condition.

A Federal program, the Injury/Illness Prevention Program (IIP), supports an operator's right to refuse to drive an unsafe vehicle.

Guidelines for this program are available from the Occupational Safety and Health Administration (OSHA).



In our organization these guidelines are located--





What three things should you know before you decide that your vehicle is ready for service?





How do you decide whether a vehicle is in safe operating condition?



OPERATOR RESPONSIBILITY FOR VEHICLE MAINTENANCE

Vehicle maintenance is a critical part of an effective emergency medical response organization. If vehicles are not ready to respond to a service

call, or if they break down during a run, the organization cannot transport patients effectively.

Comprehensive Maintenance Programs

A comprehensive maintenance program anticipates the need for maintenance and completes it before a failure occurs and repairs are needed.

Comprehensive Inspection and Maintenance Programs

A comprehensive program--

- uses information from regular inspections to identify maintenance that may be needed
- documents all inspections, work requests, and work completed
- includes preventive maintenance

Advantages of Preventive Maintenance

ADVANTAGES OF PREVENTIVE MAINTENANCE

Ensures safe, reliable vehicle operation

Reduces total cost of repairs

Minimizes major equipment failure

Preventive maintenance relies on fixing minor problems before they become major ones. It has several important advantages over repairing equipment when it breaks:

- It ensures safe, reliable vehicle operation.
- It reduces the total cost of repairs.
- It minimizes major equipment failure.



Your organization's preventive maintenance program--



Operator Responsibilities for Maintenance

You are an important part of the maintenance program.

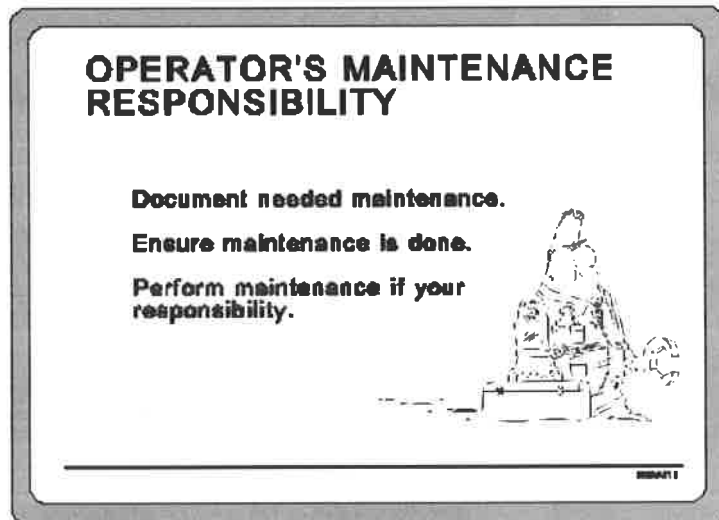

Your primary responsibilities for maintenance are--

- to document any needed maintenance you find
- to make sure needed maintenance has been completed before you place the vehicle in service

- to perform any maintenance for which your organization makes you responsible

You will document needed maintenance on your inspection checklist or other form as required by your organization.

Before you place your vehicle in service, you will make sure needed maintenance has been completed following your organization's procedures.

Performing Maintenance



In our organization the operator is responsible for these maintenance items-





Work Requests

A work request tells maintenance the work that is needed on a vehicle. When maintenance finishes the work, they record on the form the work performed, tests run, and the results of their efforts.



Refer to Appendix E, the Sample Work Request.

Appendix E: Sample Work Request	
	<p>As you can see, this work request covers those problems that you find during an inspection as well as routine preventive maintenance.</p>
	<p>An organization may or may not use a work request to track maintenance and repairs.</p>
	<p>Our organization uses (does not use) a work request. The procedures are--</p>
	<hr/> <hr/> <hr/> <hr/>
	Vehicle Maintenance Logs
	<p>Information from the inspection checklists and work requests are written into a vehicle maintenance log.</p>
	<p>The vehicle maintenance log is a vehicle's central record--</p>
	<ul style="list-style-type: none">● to list all maintenance needed and done, including routine maintenance and problems identified by inspections● to support the preventive maintenance program

- to document that the vehicle has been properly maintained



Our organization uses this system to request and track maintenance and repairs:



OPERATOR'S RESPONSIBILITIES FOR VEHICLE REPAIRS

Your primary responsibilities for repairs are--

- to document any needed repairs you find during an inspection or during a run
- to make sure needed repairs have been completed before you place the vehicle in service
- to make any repairs for which your organization makes you responsible

You will document needed repairs on your inspection checklist or other form as required by your organization.

Before you place your vehicle in service, you will make sure needed repairs have been completed following your organization's procedures.

Making Repairs

In some organizations, operators make a variety of repairs to their vehicles. In others, the operator is responsible for only minimal repairs.

You should only perform repairs for which you are **trained and authorized**



In our organization, the operator is expected to be trained and authorized to make these repairs:



Malfunctions During a Run

When this happens, think your situation through carefully before you take action. You should also use communications to give you more options.

Proper patient care should always be your first consideration.

VEHICLE MALFUNCTIONS DURING RUN

Are you trained and authorized to make repair?

Is a backup readily available?

How quickly can you make repair?

What is patient's condition?

Can vehicle's electrical system meet demand?

MMR1

Decision Aid for Vehicle Malfunctions During a Run

- Are you trained and authorized to make the repair?

The operator should be both trained and authorized to make any repair. If you should not fix the problem yourself, call for help.

- Is a backup readily available?

Use your communication system to inform dispatch of your situation and to find out if a backup is available. Develop a plan before you start any repair, in case the repair fails.

If you are operating outside your normal service area, you may

need to coordinate with an organization based in that service area.

- How quickly can you make the repair?
- What is the patient's condition?
- Can the vehicle's electrical system meet the demands made on it during the repair?



Our organization policies and procedures for malfunctions are--



Repairs You May Make on the Spot

An operator is generally expected or allowed to make only the most minor repairs during a run. For example--

- change a flat tire
- use duct tape to make temporary repairs to a broken radiator hose (usually the upper radiator hose)



Our organization trains and authorizes operators to make these repairs during a run:



Problems That May Allow You to Drive the Vehicle Safely

You may find yourself in a situation where your vehicle has malfunctioned but is still driveable.

Your decision about whether you continue to drive the vehicle should be based on your organization's policies and procedures.



Our organization policies and procedures about driving malfunctioning vehicles are--



Practice: Vehicle Malfunction Decision-Making

Suppose that you have just loaded a stable patient into your vehicle a few

miles from your usual station. Before leaving the scene, you notice that the left rear tire is flat.

What should you think through in deciding whether to change the tire or call for help?



Four horizontal lines for writing a response to the question above.



How our organization's guidelines would affect this decision:



Four horizontal lines for writing a response to the question above.

This time, you have just loaded a critical patient into your vehicle a few miles from your usual station. Before leaving the scene, you notice that your radiator is leaking and the temperature gauge is showing engine overheating. The patient is on a life support system.

What would your decision be?

	<hr/> <hr/> <hr/> <hr/> <hr/> <hr/> <hr/> <hr/>
	<p>How our organization's guidelines would affect this decision:</p>
	<hr/> <hr/> <hr/> <hr/> <hr/> <hr/> <hr/> <hr/>
	<p>Discussion</p>
	<p>What procedure does our organization use to place a vehicle in service?</p>
	<hr/> <hr/> <hr/> <hr/> <hr/> <hr/> <hr/> <hr/>

**POINTS TO
REMEMBER**

You should inspect your vehicle to decide whether it is in safe operating condition or whether it should not be driven.

You may be found negligent for driving a vehicle that is not in safe operating condition.

When you place your vehicle in service, you should indicate that the vehicle is in safe operating condition.

To determine whether the vehicle is in safe operating condition, you must know whether required maintenance has been performed.

You must understand your organization's maintenance program in order to know your vehicle's maintenance status.





You are responsible for documenting any needed repairs you find during an inspection or during a run.

Before you place a vehicle in service, make sure that needed repairs have been completed.

You and your organization should have a strategy for dealing with vehicle malfunctions during a run.

COURSE:	EMERGENCY VEHICLE OPERATOR COURSE (AMBULANCE): NATIONAL STANDARD CURRICULUM
MODULE A:	Ambulance Operation: The Basics
LESSON 6:	Navigation and Route Planning
COURSE GOAL:	To provide ambulance operators with the knowledge and skills to operate their vehicles so that their vehicle, equipment, crew, and patients will be delivered safely and efficiently and the safety of the public will be assured during all phases of the delivery of the Emergency Medical Services (EMS) involving the ambulance
MODULE GOAL:	To provide ambulance operators with the knowledge required to safely and efficiently operate an ambulance in both nonemergency and emergency modes
LESSON GOAL:	To provide participants with knowledge of strategies used to select the safest route to the emergency scene
PERFORMANCE OBJECTIVE(S):	Σ Identify those factors used for route planning
PM APPENDIX:	

PARTICIPANT MATERIALS:	
-------------------------------	--

ICON LEGEND			
			
Notes	Response	Appendix	Local Requirements

INTRODUCTION

Route selection is a key decision for both urban and rural area driving. Each time you prepare to leave for a run, you must decide on a route that is quick and avoids potential hazards or delays.

This lesson presents general information you need to help you decide which route to take to an emergency scene.

ROUTE SELECTION: PROCEDURES

Effective route selection considers procedures such as route planning, predetermined routes, and operator familiarization.

Route Planning

Safety is the most important factor when driving to the scene. You must have a route plan if you want to get to the emergency scene quickly and carefully.

Route planning involves learning the geographic and local conditions, individual characteristics of the area, and your organization's procedures to map out the most efficient route to the emergency scene.

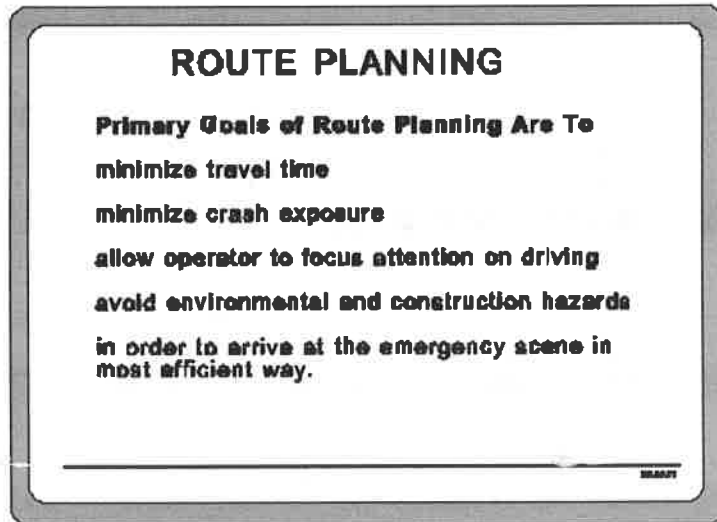

Geographic and Local Conditions

When you plan a route, think about the geographic and local conditions affecting the roads you will be using.

Be aware of and prepare yourself for the conditions in the type of area you will be driving in.



Special considerations must be made when planning a route in a rural area. What conditions could you expect in a rural area?



Street and road signs in rural areas may be limited, and directions are often given in reference to buildings, gas stations, race tracks, or other past or present landmarks. Farms are commonly referenced since farm names never change.

When responding to an emergency in a rural area, the distance you drive is usually greater. The road conditions may not always be known, and the police may not even get a call.

When you head out to the emergency scene, communicate with dispatch or directly with the first responder. In rural areas, a first responder may get to the scene before the ambulance. The first responder will have information about the patient, road, and weather conditions.

Plan ahead so you don't waste time on a run. Make sure you stay within the speed limit! Choose routes that--

- minimize stops and turns
- avoid intersections
- avoid residential streets--the posted speed limits will be slower; you must be careful of pets, children, cars backing out, and so on

Organization Procedures

A variety of resources can be used to help you with route planning. Each organization should have a procedure for updating special

events, road conditions, and other factors on a daily basis.

Your shift supervisor should conduct a briefing at the shift change. This briefing should cover any special events, route problems, personnel assignments, and so on.



Our local procedures include--



Predetermined Route Procedures

Predetermined routes are standard response routes that are prepared in advance. These routes have been selected to avoid potential problems.

Routes should be developed and maintained by your organization or coordinated with other emergency services in the area.

Route planning includes the best way to get to the emergency scene AND the best way to get from the scene to the medical facility.

On the way to the emergency scene, you and your crew should communicate and navigate the route together. It is a good idea to have at least one experienced person on your crew who knows the area.

After you pick up the patient and are on the way to the medical facility, the EMT will be busy caring for the patient and will not be able to help you navigate.

Make sure you know the route from the scene to the medical facility before the EMT begins attending to the patient.

Follow your organization's standard procedures so any two members can work together and understand what to do.

Take every opportunity to practice communicating with the crew.
Example: operator calls out road conditions, RR crossing, other bumps on the route. EMT in patient compartment calls out what they are doing to alert the ambulance operator. The operator should tell the EMT in the patient compartment of any conditions that will limit medical attention.

A good time to practice is during a practice run or when you are returning from the medical facility and are returning to your station.

Primary and Alternate Routes

When planning routes, primary and alternate routes should be identified.

Alternate routes must be available in case of bad road conditions, weather, or other situations that effect primary routes.

Navigation at night can be difficult, especially if you can't see the

street signs, hazards, or other problems. Communicate as a team and follow your organization's standard procedure for giving directions.

To make it easier to choose an alternate route, map out the local areas commonly used and refer to these maps when deciding which way to go to the scene.

- Use a grid system to show any short cuts, one-way streets, expressways, and so on.

- Add useful information that is not included on the map, such as dirt roads, dangerous intersections, very steep grades, roads or lanes on roads that change direction according to the time of day.



Our local procedure for primary and alternate routes includes--



Operator Familiarization

Operator familiarization involves your awareness of daily route information, procedures to identify local information, height restrictions, and map

reading.

When you get a call from dispatch, you are responsible for knowing how to get to the scene safely and without taking unnecessary risks. If you don't know the streets and the area you'll be driving the ambulance in, you could easily get lost.

Daily Route Information

Become familiar with your area to prevent getting lost.

- Review the primary and alternate routes you usually drive.
- Find out if there are new developments and buildings under construction.
- If you are in an area with limited road and street signs, learn the local references, such as buildings, farms, gas stations, and so on.
- Review and learn about different activities that may affect the traffic flow of your route each day.

Your area has buildings that you need to pay particular attention to everyday. Can you think of types of buildings that may have scheduled activities in which you need to be aware of?



Keep in mind the approximate busy times for the buildings we just listed. Expect delays in high traffic building areas during these times:

- beginning and end of normal work and school day
- shift-change times for large factories, hospitals, and so on

Your daily route can be effected by the weather and other environmental reasons:

- emergency snow routes
- roads closed due to flooding

Watch for changes in the condition of local roads and streets. Potholes and bumps can give the patient greater discomfort and possibly aggravate the patient's medical condition.

Be aware of the following conditions of local roads and streets:

- damage, potholes, badly rutted roads
- expressway utilization policies during rush hour or construction

- detours, closed roads

- speed bumps, dips, bumps

- areas of standing water

Dispatch can help when it is absolutely necessary; however, it is your responsibility to know the conditions of the area before you leave.

Procedures to Identify Local Information



How could you find out about different activities in the area that may affect your route?



Height Restrictions

When would ambulance height be important in route planning?



Keep the height posted in the vehicle where you can quickly see it during the run. The dashboard or visor would be good places to post the vehicle height.



If you and your partner were on your way back to the station after a run and had to pass under this overpass, could your vehicle pass under this height obstacle?



Why is route planning important?





When you plan a route, what factors should be considered?



Why must alternate routes be available?



	<p>What do you need to be familiar with so you can get to the emergency scene quickly and carefully?</p>
	<hr/> <hr/> <hr/> <hr/> <hr/>

**POINTS TO
REMEMBER**

Route selection is necessary for you to get to the scene quickly and carefully. Route planning, predetermined route procedures, and operator familiarization all contribute to effective route selection.

Choose a route to arrive at the emergency in the most efficient way. Minimize travel time, minimize crash exposure, and allow the operator to focus attention on driving.

When planning a route--

- consider geographic and local conditions
- utilize your organization's procedures
- Use predetermined routes to avoid potential problems on the road.
- If primary routes are not in good condition, use alternate routes.





You should be familiar with--

- daily route information
- procedures to identify local information
- height restrictions
- how to read a map

COURSE:	EMERGENCY VEHICLE OPERATOR COURSE (AMBULANCE): NATIONAL STANDARD CURRICULUM
MODULE A:	Ambulance Operations: The Basics
LESSON 7:	Basic Maneuvers and Normal Operating Situations
COURSE GOAL:	To provide ambulance operators with the knowledge and skills to operate their vehicles so that their vehicle, equipment, crew, and patients will be delivered safely and efficiently and the safety of the public will be assured during all phases of the delivery of the Emergency Medical Services (EMS) involving the ambulance
MODULE GOAL:	To provide ambulance operators with the knowledge required to safely and efficiently operate an ambulance in both nonemergency and emergency modes
LESSON GOAL:	To provide participants with knowledge of how to operate an ambulance in order to improve the safety and quality of ride for an ambulance patient
PERFORMANCE OBJECTIVE(S):	<ul style="list-style-type: none"> ● Identify five road construction and engineering factors affecting ambulance control and ride quality for an ambulance patient ● Identify driving skills that affect the ride quality for an ambulance patient ● Identify things an operator must do to maintain a safety cushion around the ambulance ● For each basic driving maneuver listed, select the

	recommended procedure to be followed when driving an ambulance

PM APPENDIX:	
PARTICIPANT MATERIALS:	

ICON LEGEND			
			
Notes	Response	Appendix	Local Requirements

INTRODUCTION

When you have a medical team and a patient in the back of your ambulance, they are counting on you to get them quickly to the hospital without making the patient's condition any worse than it already is.

ROAD CONSTRUCTION AND ENGINEERING

Road Surfaces

While the road surface greatly influences the quality of the ride, you can't control it or change it. You must learn how to adjust your driving to match the road conditions.

When roads are built, engineers plan each road to handle different kinds of traffic and use different materials to build each road.

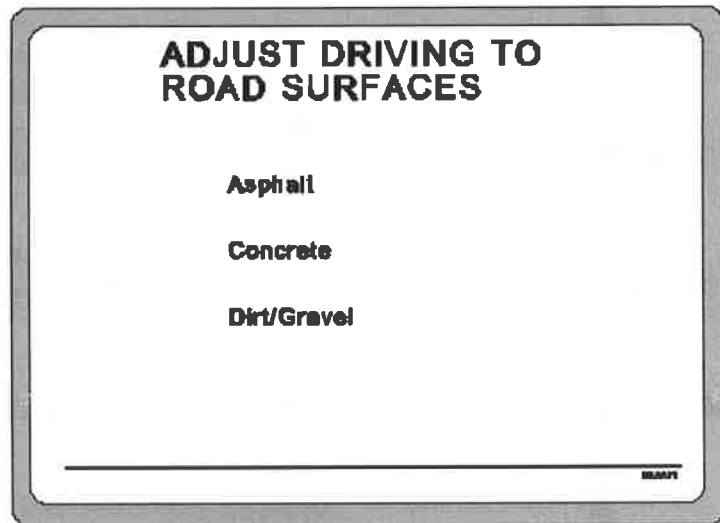

Asphalt

Asphalt is not as durable as some other common surfaces and requires repair more often. Repairs normally consist of patching the surface with more asphalt material or with tar to fill in cracks. These patches then create bumps in the road.

Asphalt is at its worst during the hot summer months. When it's very hot, the oils used to make asphalt bleed to the surface, making it slick, especially when it rains.

An asphalt roadway can also roll up become wavy with heavy use during extremely hot days. Not only is that very uncomfortable to ride over, but

you do not have full control of your ambulance since your tires are in contact with the road only half the time.

Concrete

During hot weather, concrete expands and may break up at its joints, leaving a hole in the surface.

Concrete also settles more than other road surfaces. As the earth under it settles, the concrete sections develop severe dips, causing the ambulance to bounce heavily between dips.

Concrete road surfaces also glaze over very quickly in freezing conditions, much more so than asphalt.

Dirt/Gravel

Dirt and gravel roads are tricky to drive on if you're not used to them. Because of the irregular shape, size, and weight of the stones, they move about easily. This movement can cause a vehicle to go out of control with only a slight action by the operator. Braking on gravel can cause a vehicle to slide easily.

When following another vehicle on dirt and gravel roads, stay back to increase visibility and to avoid flying stones.

Transitions Between Surface Types

When transitioning from one surface type to another, such as from hard surface to gravel, you must change your driving style before moving onto

the gravel road or you could loose control of your ambulance.

Road Conditions



What road conditions might effect your ride?



Four horizontal lines for writing an answer to the question above.

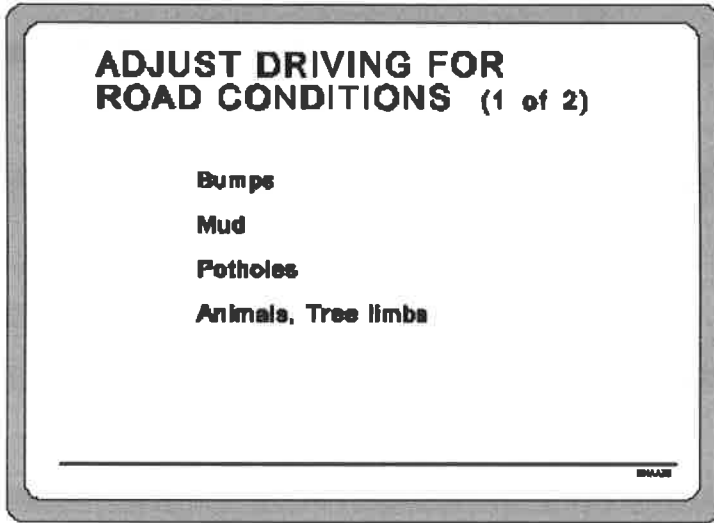

Bumps



How will you know when you are approaching a bump in the road?



One of the easiest ways to see a bump in the road ahead is to watch the vehicles ahead of you bounce as they hit the bump. This gives you time to slow the ambulance and lessen the effects of the bump.

Another way to see bumps is to look at the road surface itself. A clear path in the center of the roadway followed by a dark spot indicates a large

dip or bump in the road. When vehicles hit the bump, loose oil and debris under the car fall off, creating the dark spot.

Mud

Mud on the roadway causes problems, first by creating a slick surface, and second, by filling the tread pattern of the tire and making the reaction ability of the tire very slow.

Potholes

Potholes are holes in the road surface, sometimes at the joint of a concrete road or, more commonly, where a asphalt surface has failed. Potholes cannot be easily fixed and keep returning, getting wider and deeper each time they reappear.

Potholes give us two problems. First, they can destroy the ambulance's tires or suspension system. Second, they can cause you to loose control as one corner of the ambulance drops into the hole and the ambulance frame twists. Both problems cause hardship for the medical personnel and increase the pain level of your patient.

During your prerun route planning, be sure that you select roads known to be free of potholes. And, if you discover potholes during your run, pass this information on to the dispatcher so that the route information can be updated.

The best way to handle a pothole is to try to drive around it.

If you must drive through a pothole--

- release your brakes just as you get to the pothole

- hit the pothole squarely, rather than on the side of the tire

Animals, Tree Limbs, and Miscellaneous Objects

Everyone's natural reaction is to swerve to avoid hitting objects in the road, but this often causes more problems than the object itself. Instead of swerving--

- if it is a small object, hit the object head-on
- if it is a large animal or object, maintain control of your vehicle and attempt to avoid a head-on collision

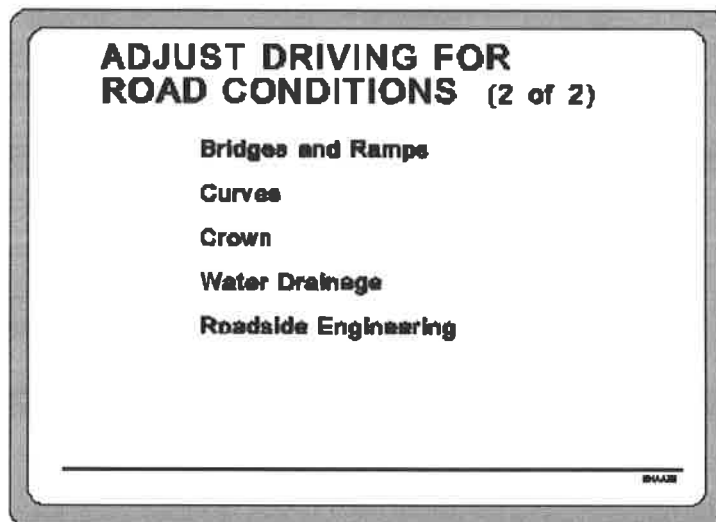

Bridges and Ramps

Bridges often have an open metal grating over the main expanse of the bridge. When the ambulance's tires cross this grating, the tire tread tries to align itself with the grating, causing the wheels to jump and jerk. The best way to handle the grating is to slow while approaching the bridge and then hold the steering wheel firmly in both hands. There will still be some jerking of the wheel, but you should be able to control it by using both hands.

Bridges and ramps often have a reinforced concrete bed, which will freeze before the roadway on either side. This is because, as the temperature drops, the cold air circulates around the concrete bed of the bridge or ramp and the concrete becomes cold faster than the roadway that is built on the warmer ground. Use caution when driving on bridges and ramps during freezing temperatures.

Curves

When highway engineers design a new roadway, they use the natural contour of the land. Most of the time, they can reform the land slightly and create comfortable roads. Sometimes, they can't. In hilly or mountainous areas, following the land's natural contour often results with roads designed with deep or multiple curves.

Never take a curve for granted. Enter a curve carefully, following the posted recommended speed limit for the curve, and watch how the curve changes as you continue. If it gets tighter, slow down even more to retain control of your ambulance.

Banking

Most curves in today's highways are banked to help maintain

speed while going through the turn. If a roadway is built so that the inside of the curve is lower than the outside edge, then it is banked properly. If the inside edge is level with or higher than the outside edge, you will have to slow down in order to complete the curve.

Posted speed limits

The speed limits posted at the beginning of most curves is the recommended speed that allows you to safely continue through the curve. This speed is often lower than the prevailing highway speed because of the amount of banking or because the curve is a compound curve.

Crown

Older roads and those in areas that receive a lot of rain often have a crown in the middle of the road. When a road has a crown, the center of the road is higher than both edges. Since the crown is normally not very high, it does not pose a problem on a straight road, but in a corner, the crown acts like improper banking and works against the vehicle going around the corner. Slow down in order to retain control of your ambulance.

Water Drainage

Road crowns are essential for good water drainage during rainy periods. When water drains quickly from the road surface, the danger of hydroplaning is reduced. Some concrete roads accomplish drainage by cutting grooves into the road surface.

Hopefully, the water will drain completely away from the road, thus eliminating the dangers of hydroplaning and possibly losing control of your vehicle. You must look ahead and remain clear of areas of standing water

and water collected alongside the roadway.

Roadside Engineering

Roadside engineering consists of all the signs, guardrails, and barriers along the roadway. These include your speed limit, no passing, and intersection signs, and the safety barriers beside deep ditches or bridges.







How could roadside engineering effect the quality of ride you give your patient?





Are you more likely to have control problems going from concrete to gravel, or from gravel to concrete?



	<p>If you are driving down a highway with very little traffic and in your lane ahead, you notice a dark spot in the middle of your lane, what would that indicate and what would you do?</p>
	<hr/> <hr/> <hr/> <hr/>
	<p>You are driving through a hilly area after picking up a teen-aged boy with a broken leg, it has been raining heavily, and there is a lot of traffic on the road. Up ahead, it looks like some mud has slid from someone's yard onto the roadway. What is the problem and what would you do?</p>
	<hr/> <hr/> <hr/> <hr/>
	<p>Just before you get to the mud, a small tree branch falls into the roadway in front of you. What would you do?</p>





What problems might you have on asphalt in August when the temperature is 101 degrees?









As you round a curve in the highway at 50 mph, with a patient on board, you see a deep pothole in the right tire track on your side of the highway. You firmly press your brakes to slow, but realize that you cannot change lanes and are going to hit the pothole. What should you do?



It's night and you come over a hill. In your lane stands a full-grown deer

	<p>looking at you. There is a car coming toward you in the other lane and there is a deep ditch on your right. What should you do?</p>
	<hr/> <hr/> <hr/> <hr/> <hr/>
	<p>DRIVING SKILLS WHICH INFLUENCE THE QUALITY OF THE PATIENT'S RIDE</p>
	<p>Adverse Effects on Patient When Riding in an Ambulance</p>
	<p>What would be some of the adverse effects of riding in an ambulance? First, consider the patient.</p>
	<hr/> <hr/> <hr/> <hr/> <hr/>

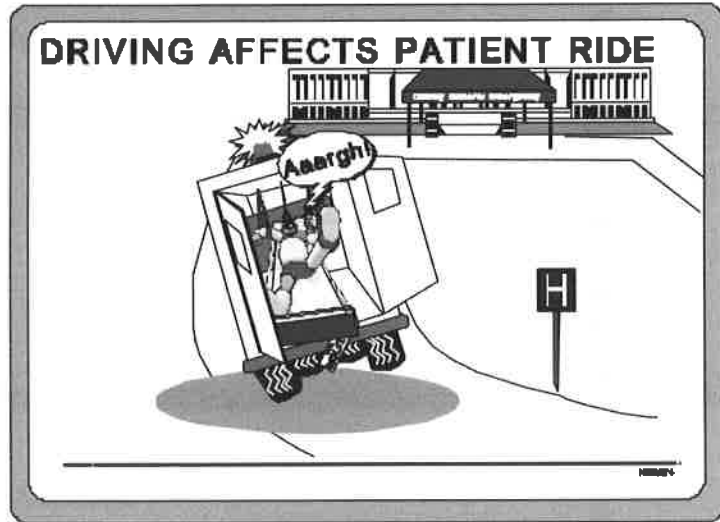

Both sick and injured patients may feel nauseated. When you place them on the stretcher and put them into the ambulance head first, they may become even more nauseated from motion sickness. If the ride you provide is not smooth and comfortable, their nausea may increase and they may vomit, causing further complications for your medical crew.

Also, patients will tense their muscles to counteract the pitching forces encountered in turns and while braking and accelerating. When patients have broken bones or internal injuries, the muscle contractions will aggravate their condition.

Adverse Effects on Medical Team When Riding in an Ambulance



What would be some adverse effects on the medical team?



Patient care cannot continue if your medical team has to hold on to survive. Patient care must continue uninterrupted while enroute to the hospital.

Several basic and advanced life support skills are difficult to perform in a moving ambulance, no matter how smoothly it is driven. These skills are impossible if the ambulance is bouncing and swaying as it is driven down the road. For example, studies have demonstrated that CPR is best performed in a moving ambulance that is being driven at speeds below 25 mph and not being driven in the emergency mode.

How Driving Skills Influence the Quality of the Patient's Ride

There are four main driving skills that we are going to talk about. They are cornering, braking, accelerating, and maintaining appropriate speed.

Ambulance Suspension System

Remember, like most cars and trucks, the ambulance is a body that is attached to the engine and wheels with a suspension system. The suspension system is designed to do two things. First, it is designed to keep all four wheels firmly on the ground, no matter what the surface is like, so that you can steer, have brakes, and accelerate. And second, it is designed to isolate the body and its occupants from the bouncing of the wheels when they hit bumps and uneven road surfaces.

Because of the way the suspension system is designed, when you speed up, brake, or take corners, the body leans. Because an ambulance is a

heavy vehicle and full of equipment, it has a stiff suspension and the amount of lean is not great, but it must still be taken into account when driving.

Cornering

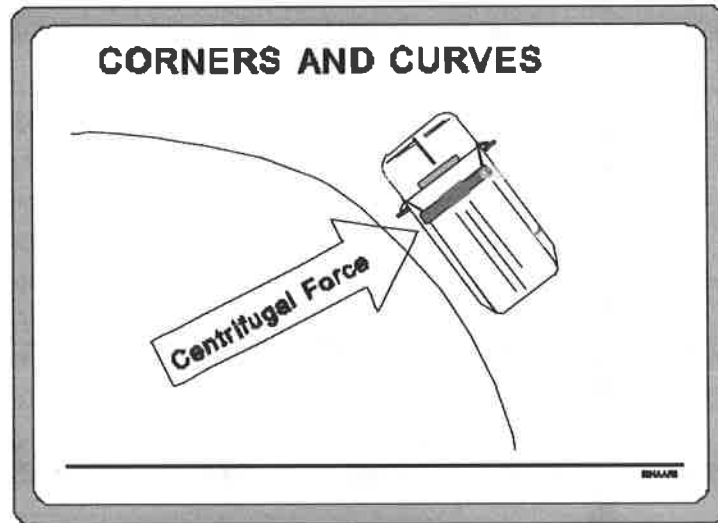

There is a force that must be considered when going around a corner or a curve. That force is called centrifugal force, and it throws a body toward the outside of a curve as the vehicle goes around the curve.

For example, if you travel down the highway at 55 mph and enter a curve to the left, you feel yourself being pushed toward the right side of the vehicle. You naturally lean to the left to counteract this push. That works fine for the passengers sitting upright in the seats.

But the patient strapped to the stretcher can't lean. And the medical team can't lean, and their equipment can't lean. Reduce the force by slowing down and making smooth turns so that the patient can balance and stay balanced throughout the turn.

Braking

Body lean is a very important factor when you brake or when you accelerate. When you brake hard, the nose of the ambulance drops downward and all the weight of the ambulance, and its occupants, shifts toward the front. When you accelerate hard, just the reverse happens. Everything shifts toward the back.

Just like when cornering, body lean is not a big problem for you because you are sitting upright in a seat with your seat belt on. But the medical team and the patient aren't so lucky. They are being thrown forward and backward as you brake hard and then accelerate. And they can't see what's coming so that they can brace themselves. You have to protect them by braking no harder than necessary and by accelerating smoothly and steadily.

When braking, you must take two factors into consideration: reaction time and braking time

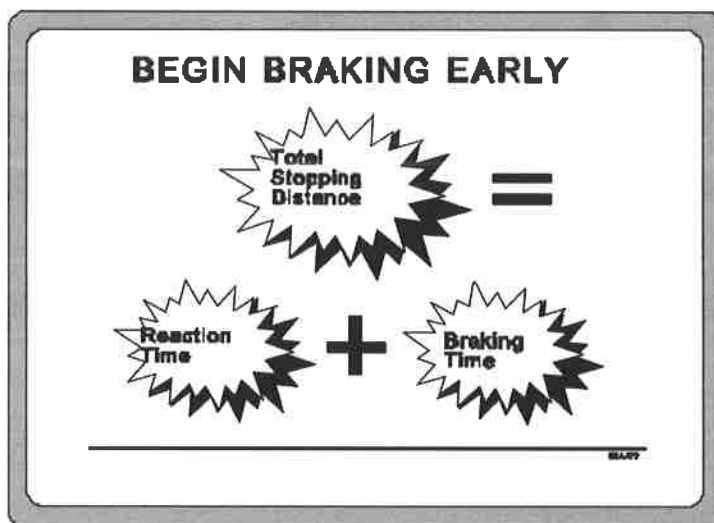

Reaction time is a combination of the time it takes you to see and understand that you will have to brake and to actually move your foot to the brake pedal.

Braking time is the time it takes your brakes to bring the ambulance to a complete stop.

Total stopping distance, then, is equal to the reaction time plus the braking time.

Training can reduce reaction time. When the brain is under stress, as it is when you recognize a problem ahead, the body will react the way it was trained to react.

In Lesson 1 we talked about factors that can affect your reaction time-- illness (e.g., cold, flu), a physical injury that could affect your ability to maneuver the ambulance, medication(s), and lack of sleep.

All of these factors influence your reaction time and ultimately determine if you will be able to stop in the time (distance) available. You need a way to maximize the time and distance available for braking by placing your ambulance in the safest position.

2-4-12 Rule

2 4 12 Rule

2 second interval below 55 mph
4 second interval above 55 mph
12 second visual lead time

The 2-4-12 rule says--

- maintain a 2 second interval between your ambulance and the vehicle ahead for speeds below 55 mph
- increase the following distance to 4 seconds when speeds get above 55 mph to allow for increased stopping distances at higher speeds
- give yourself a 12 second visual lead time. In other words, look ahead for possible hazards and alternate paths of travel should an emergency arise

Use your 12-second visual lead time to constantly make speed and position adjustments. Simplify your choices as much as possible. Don't tackle more hazards than you absolutely have to.

For example, if you are looking 12 seconds ahead, you will see the traffic light almost a block away turn red. You are able to respond by removing your foot from the accelerator and begin slowing early. Then by smoothly applying the brakes, you can bring the ambulance to a stop without having to slam on the brakes. When traffic clears and you can proceed forward, you can gently release the brakes and begin to accelerate at a steady pace. As you continue to look ahead, you begin slowing for that next corner and make a smooth turn that doesn't throw the patient from one side to the other.

Look ahead, see what is happening all around you, and begin your actions early. Your driving will improve and you will begin providing a smooth ride for your crew and your patient.

Accelerating

To reduce body lean and strain on the patient and the medical team, accelerate smoothly and steadily.

Provide a comfortable ride by using a smooth, slow rate of acceleration.

This method requires that initially you apply a feather-touch to the accelerator and then continue to move the accelerator pedal downward gradually but steadily. As you approach the desired speed, hold the accelerator still for a moment and begin to ease up on the accelerator to the point where you are using just enough engine power to maintain the selected speed.

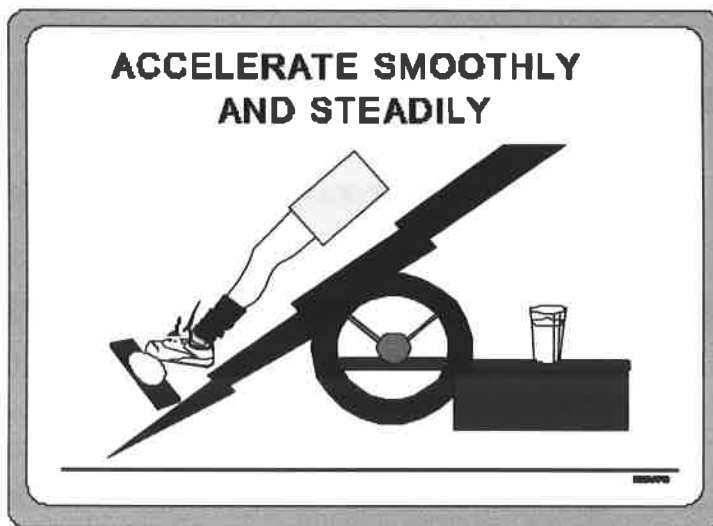

To practice, you can do two things. First, pretend there is a raw egg between your right foot and the accelerator pedal. Try not to break the egg. The second thing is something you should practice but not do on a run. Place a half-full glass of water on the dash and try to accelerate (and brake and take corners) without spilling any of the water.

Speed



If two ambulances are going down the same road, one at 55 mph and one at 35 mph, which one do you think is providing the smoother ride?



High speed makes the ride rougher than lower speed does. The faster an ambulance goes, the more it bounces. Each turn of the steering wheel throws the ambulance harder from side to side.



Our local regulations concerning speed include--



Four horizontal lines for writing, located in the right column of the table.

High speed normally makes the patient's ride so much worse that it is actually detrimental to the patient, not beneficial. You may get to the hospital faster, but you may have made the patient's injuries worse just from the bouncing. And the medical team hasn't been able to work because they had to hold on to counteract the effects of a less than smooth ride.

Most patients are stabilized and on life support, if necessary, before the ambulance leaves the emergency scene. Therefore, speed is not as necessary when transporting the patient to the medical facility.

Slow down for curves and corners and take them smoothly. Brake

smoothly and no more than is required. Accelerate smoothly and steadily and go no faster than necessary.



The driving skills we want to improve are involved in what four phases of driving?





What's the best way to improve these driving skills?





Total stopping distance equals?



There is a delicate balance between the operator, the machine, and the environment:

- The machine, your ambulance, is the most reliable and is responsible for only one percent of crashes.
- The environment is constantly changing and is responsible for approximately ten percent of the crashes.
- The operator is responsible for a large percent of ambulance crashes. The operator is also responsible for the successful merging of the three-part relationship.

Preventable Collisions

Most collisions are preventable.

The key to preventing collisions is called **situational awareness**. This means that you must be constantly aware of your situation by remaining alert at all times, knowing what's going on all around the ambulance, and driving defensively.

Defensive Driving

What is defensive driving?

DEFENSIVE DRIVING

**Avoid Preventable
Crashes**

Defensive driving means doing everything reasonably possible to avoid being involved in a preventable crash, regardless of what the law is, what the other driver does, or adverse driving conditions.

Defensive driving requires continual exercise of good judgment and good driving habits with an awareness that all other drivers cannot be relied upon to drive properly and safely.

Expect the unexpected and be prepared to act. Have a plan of action at all times. Remember, you have the final responsibility for your safety and that of your passengers.

Maintaining a Safety Cushion



What do you think "maintaining a safety cushion" means?



Maintaining a safety cushion means driving so that you position your vehicle in relation to other vehicles and possible hazards so that you have a cushion of empty space completely surrounding your ambulance.

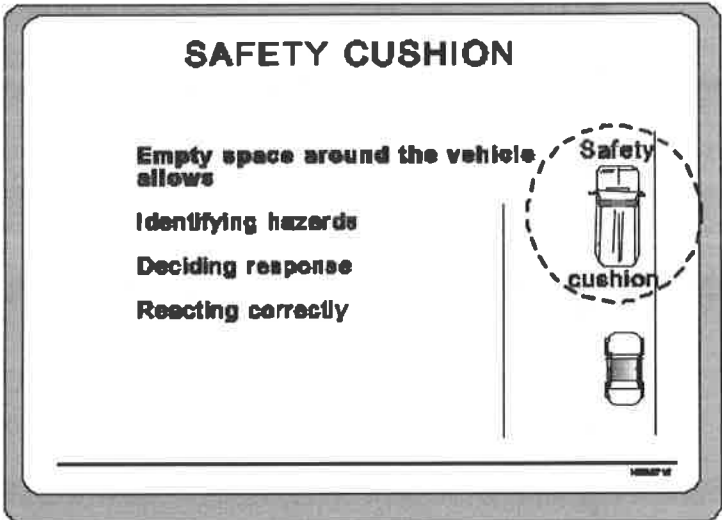

You want to allow enough room around the ambulance so that you can identify possible hazards, decide on a course of action, and react by either bringing the ambulance to a controlled stop or maneuvering to avoid the hazard.

 Why would you want to maintain a safety cushion of empty space around the ambulance?



In a road emergency, you don't want to get boxed in without an escape route. Maintaining a safety cushion around your ambulance, reduces your chances of being involved in a crash.

Obviously, the safest position for the ambulance is as far away as possible from any possible collision. It's easy to be involved in a crash when there are vehicles in front, beside, and behind you.

 Why should you be concerned about vehicles behind you?



Tailgaters

Tailgaters are people who follow too closely behind the vehicle in front of them. Normally, they are so close that if you have to stop suddenly, they don't have time to stop or prevent running into the back of your ambulance.

Don't allow other drivers to tailgate you. Use any method to make them pass or fall back. If necessary, slow and pull to the right of your lane to encourage them to pass. Tailgaters are safer for you if they are tailgating the vehicle in front of you. You at least can see them and plan your action if they run into the other vehicle.

Multiple Responding Units



Why would multiple responding units be a problem behind your ambulance?



Emergency units responding along the same route should maintain 300 to 400 feet of distance between them. To make sure the other motorists know there is more than one emergency unit in the area, use a different siren tone than the vehicle ahead of you. Change tones at intersections and allow your siren to partially wind down prior to the intersection so that both you and the other motorists will be alerted that there are multiple emergency vehicles in the area.



Local regulations regarding multiple responding units include--



Communication

To get the maximum advantage from proper positioning, your safety cushion, and defensive driving, you must communicate with other drivers.



How can you, when driving the ambulance, communicate with other drivers?



COMMUNICATION WITH OTHER DRIVERS

Lights
Horn
Eye contact
Hand signals
Siren

Remember: always expect the unexpected from the other drivers. Don't assume that they see or hear you. And even if they do see and hear you, don't assume that they will give you the right of way.

PRE-CRASH PLANNING

Sometimes a crash is going to happen, even though you have done everything you could to avoid it. You need to plan ahead for that situation and think about how you are going to handle it.

To reduce the effects of a crash--

- keep the doors locked. A locked door will withstand many times more strain in a crash than an unlocked door.
- always wear your seat belt. It's the best protection you have in a collision.



Our local regulations for seat belt use include--



- Keep loose items, such as clipboards, secured. Properly secure your equipment to reduce the number of potential missiles inside your ambulance.

PREPARING FOR THE INEVITABLE CRASH

Your first priority is to protect yourself and your passengers from death or injury. The next priority is to reduce vehicle damage. But remember, you and your crew are more important than your vehicle.

The key to surviving an inevitable crash is to REDUCE. First, reduce the speed of the impact. The lower the speed, the lower the energy levels involved and the lower the probability of death or serious injury.

Next, reduce the angle of impact. Try for a glancing blow rather than a direct blow, such as a head-on collision.

Third, reduce the size and hardness of the object you are going to hit. For instance, if you are going to leave the road, try to steer into a grassy field instead of trees, or into small saplings and bushes rather than into larger trees.

If you are absolutely sure that you are going to strike something, try to hit it with the part of the ambulance the furthest from you--the right front or right rear--even if it places your passengers in greater jeopardy. Remember, only the operator can control the ambulance after the initial impact. You may still need to steer the ambulance to reduce injury and damage, not only to yourself, but to others.



If I notice that I have a tailgater riding my bumper, what should I try to do?





Why do I want to maintain a safety cushion around my ambulance?





In order to prevent crashes, how can I communicate with other drivers?



Four horizontal lines for writing, located in the top-right section of the page.

BASIC MANEUVERS

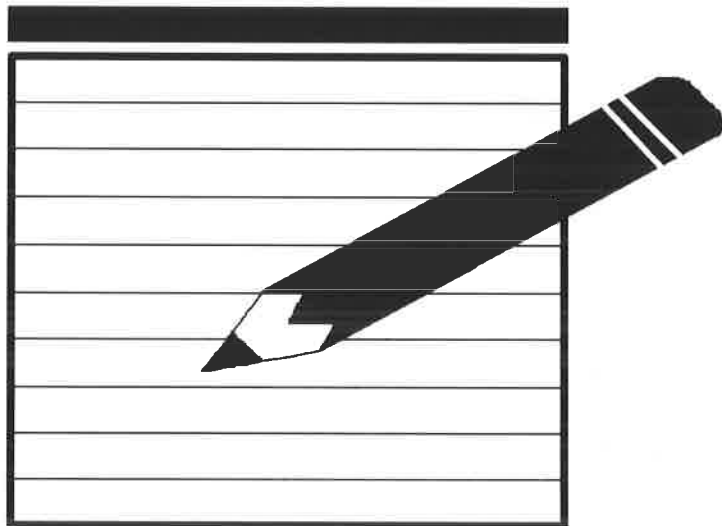

BRAKING AND STOPPING

Pump brakes gently but firmly.

Check conditions to rear and side.

Search 12 seconds ahead.

Braking and Stopping

Braking is very effective in stopping your ambulance if it is done properly, but it can be hazardous if you do it improperly. If you apply too much pressure and lock the brakes, the wheels will skid and you will lose steering control. If all four wheels skid, the rear end of the ambulance may slide to the side and you will lose control of the vehicle. To avoid these problems, you must keep the wheels turning.

Apply pressure on the brake pedal with the upper half of the right foot, preferably with the heel contacting the floor. Try to pivot on the heel for greater sensitivity on the pedal. This involves fewer leg muscles and reduces unwanted "pumping" or "lock-up" of the brakes.

In a straight line, the most efficient way to brake to a stop on any surface is by gently but firmly pumping the brakes. Braking, when properly done, involves firmly pressing the brakes to the point before lockup, then gently releasing them so that there is a minimum amount of front-end weight change and bounce. The main point is to never lock-up the brakes.

Avoid staring at the front hood of the ambulance while braking. Check the conditions to the rear to avoid being hit from behind. Check conditions to the side in an effort to find an escape route. Search 12 seconds ahead to see if the conditions which forced your braking actions have changed.

Making Lane Changes

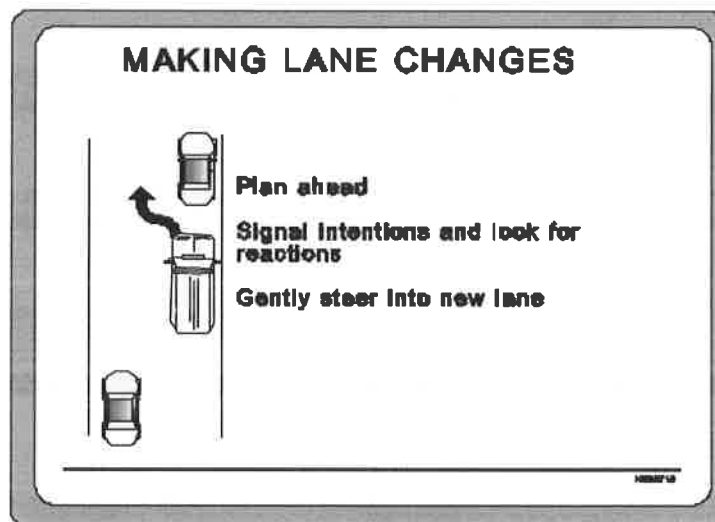

When making lane changes on a multilane road, use the 12-second method and plan your lane change well in advance. Signal your intentions and look for reactions from the other drivers. If the new lane remains clear, gently steer into the new lane and continue straight ahead. A properly executed lane change should be smooth, and your passengers should never feel the change in the position of the ambulance.

When changing lanes for passing on multilane highways--

- check other lanes for problems and a clear path

- check your mirrors to find an opening in the adjacent lane
- signal your intentions by having the signal lever in the "on" position for at least three seconds before changing lanes
- check your blind spot by making a quick glance over your shoulder in the direction the vehicle is to travel
- slightly turn the wheel for a smooth, gradual, accurate movement
- control your speed with a slight increase in speed, if required.
- time vehicle arrival into the adjacent lane to avoid interfering with other traffic

Passing

Passing on two-lane roads

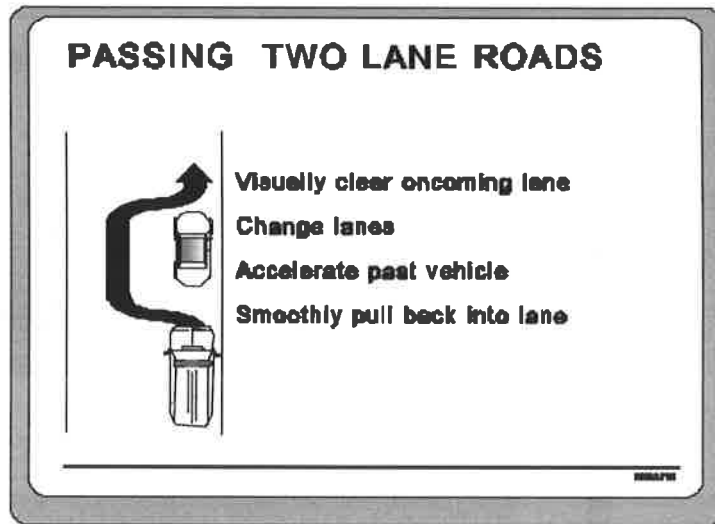

Passing on a two-lane road is a very dangerous maneuver because, for several moments, you are in the lane of approaching traffic. Your closing speed on the approaching vehicle is the total of your speed and their speed. When passing at 55 mph, your vehicle and the oncoming vehicle will be about 1/2 mile closer at the end of the passing maneuver than when you started. You have to ask yourself whether you have the space and if the risk is worth the few seconds saved.

To pass a slower vehicle on a two-lane road, visually clear the oncoming lane, change lanes, accelerate past the slower vehicle, and smoothly pull back into your lane in just a matter of a few seconds.

Passing Stopped Traffic

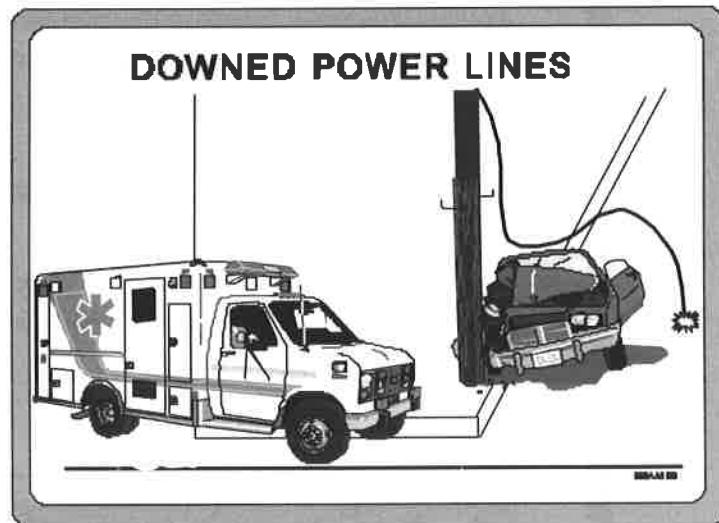

Attempting to pass stopped traffic is a hazardous situation. You should pass stopped traffic only when you are able to determine the reason for their stopping. While you are passing stopped traffic, part of your escape route has been eliminated and if oncoming traffic suddenly appears or one of the stopped drivers suddenly pulls in front of you, you may have nowhere to go.

Backing

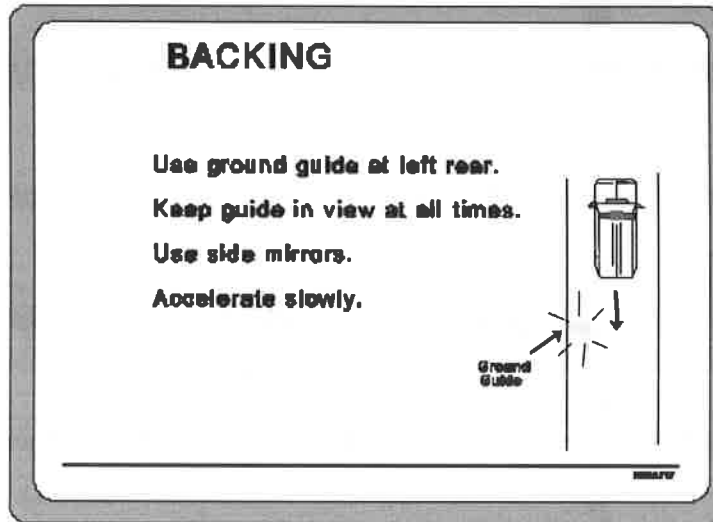

Childs and Ptacnik, in *Emergency Ambulance Driving*, report that backing accidents account for 85 percent of all single-vehicle crashes involving ambulances. This is normally a very slow maneuver, but remember that the area directly behind the ambulance is not visible to the operator. If backing is going to be necessary, it is best to do the backing when you first arrive at the scene.

Always use a ground guide positioned at the left rear of the ambulance to help. Position the guide so that you can see him or her in your side view mirrors and so that the guide can see all the obstacles behind the ambulance. Use agreed-on hand signals and, if there is any confusion, stop and clear up the confusion before continuing. When backing, you will either back in a straight line or make turns while backing. For straight line backing--

- position your body so that you can properly use the side view mirrors
- position both hands on the wheel, either at ten and two o'clock or at nine and three o'clock

- make sure that you have a clear view to the rear

- begin to accelerate slowly

- keep hand movement on the steering wheel to a minimum

For turning while backing--

- position your body so that you can properly use the side view mirrors

- position both hands on the wheel, either at ten and two o'clock or at nine and three o'clock

- frequently check the front corners of the vehicle--remember that, as you turn, it is the front end that moves sideways

- begin to accelerate slowly

- turn the steering wheel while maintaining firm control, always keeping your hands on the wheel

- maintain speed control; in close quarters, creep the vehicle

Parking

Correct parking of the ambulance prevents it from being hit by other

vehicles at the scene of a crash or at the hospital. Parking in an urban setting is the toughest parking problem because you have to search for a place to park and then squeeze your ambulance into a tight space while trying to keep from impeding other traffic or getting your ambulance hit by other vehicles.



Our local policy on parking at crash sites and hospitals is--



Perpendicular or Stall Parking

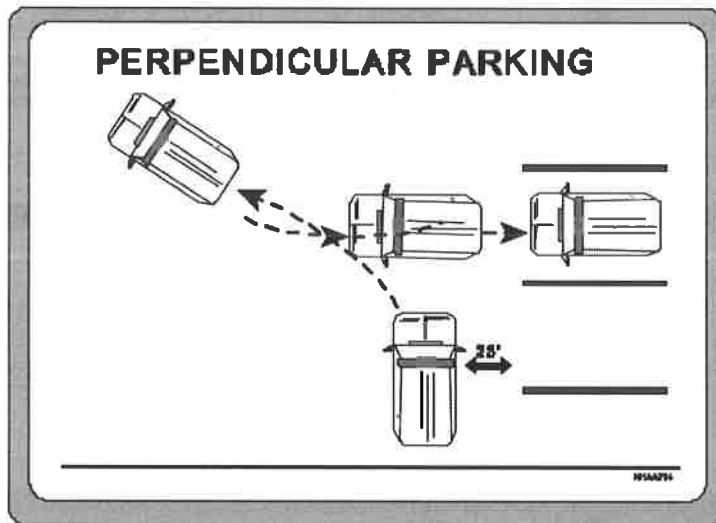

	<p>Backing into a perpendicular parking space is highly recommended. To park in a perpendicular space--</p>
	<ul style="list-style-type: none">● use a ground guide
	<ul style="list-style-type: none">● position the ambulance two to three feet from the parked vehicles on your right
	<ul style="list-style-type: none">● stop the ambulance when the operator's body appears to be lined up with the center of the parking space
	<ul style="list-style-type: none">● select a 45 degree target--use the left corner post blind spot of the windshield as a target guide
	<ul style="list-style-type: none">● creep forward while rapidly turning the steering wheels--check for traffic. Aim for the 45 degree target. Set the tires straight.
	<ul style="list-style-type: none">● shift into reverse
	<ul style="list-style-type: none">● line your vehicle up with the space and, looking over your right shoulder, aim the vehicle for the space
	<ul style="list-style-type: none">● back to the rear pivot point
	<ul style="list-style-type: none">● creep backward and turn the steering wheel

- get the vehicle straight in the space
- creep backward and straighten the wheels
- back to the rear parking line

Angle Parking

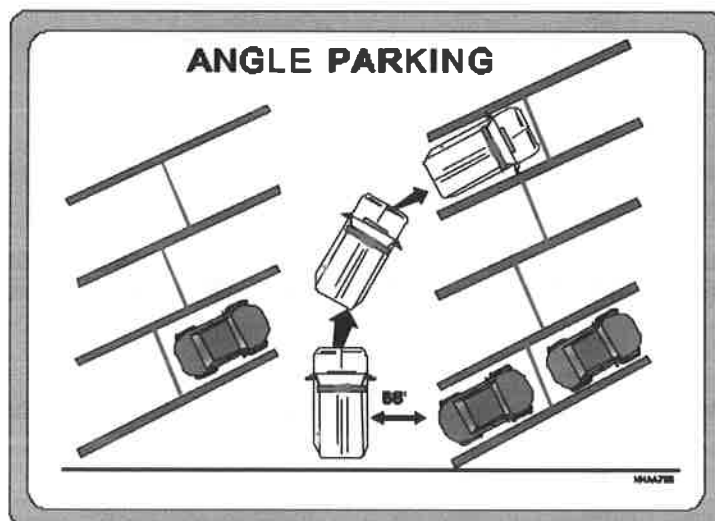

Angle parking is used when there are 30 to 45 degree angle parking spaces. This type of parking is designed for head-in parking. Follow these steps when parking in an angled space:

- before parking, check the side view mirrors and check the parking space

	<ul style="list-style-type: none">● position the ambulance at least six to eight feet away from the side of the parked vehicles
	<ul style="list-style-type: none">● see the center of the space without your line of sight curving across the parking line
	<ul style="list-style-type: none">● creep forward and turn the wheel
	<ul style="list-style-type: none">● line up with target in center of space
	<ul style="list-style-type: none">● straighten the wheels
	<ul style="list-style-type: none">● stop at front parking line
	<p>To back out of the angle parking space--</p>
	<ul style="list-style-type: none">● use a ground guide
	<ul style="list-style-type: none">● back slowly
	<ul style="list-style-type: none">● check the traffic as you back up
	<ul style="list-style-type: none">● check all corners of the vehicle
	<ul style="list-style-type: none">● clear the fender of the car on the left, then turn the steering wheel hard

- straighten the wheels

- shift to drive and move forward

Turning

The simplest turns are the right and left corners.



On two-way streets, which takes more time and space to accomplish, a right turn or a left turn at a corner?

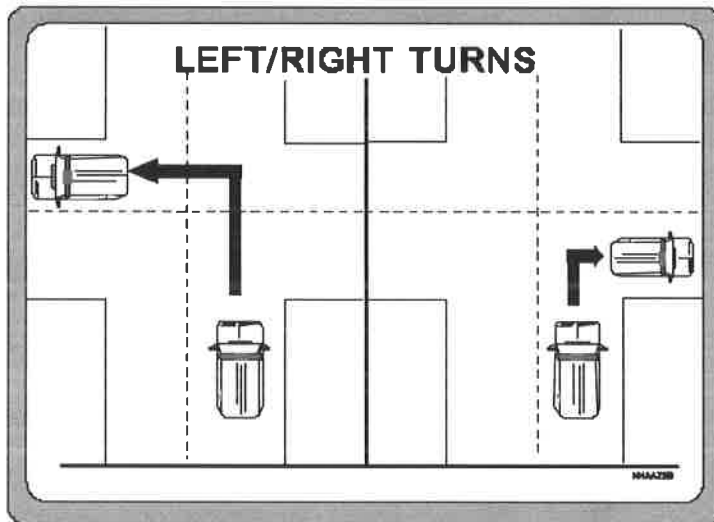



What is another difference when making a left turn than when making a right turn?



The U-turn also leave your vehicle exposed to both oncoming and ongoing traffic.

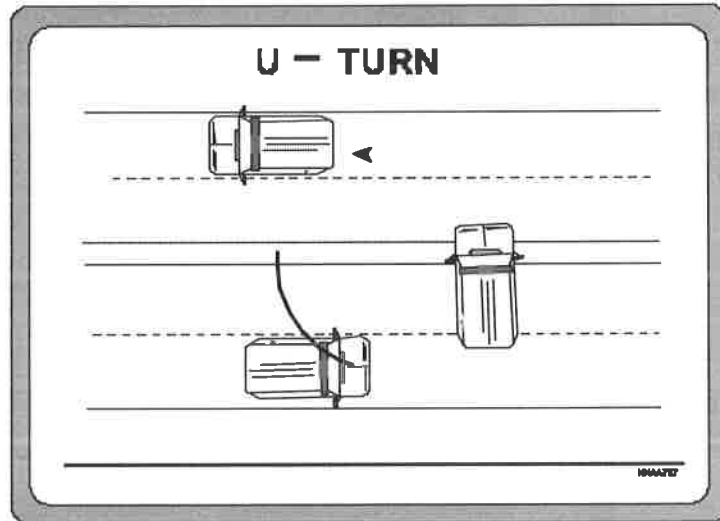

To make a U-turn on a road without a median strip--

- slow the ambulance

	<ul style="list-style-type: none">● pull to the extreme right of lane or onto the shoulder
	<ul style="list-style-type: none">● check traffic in both directions
	<ul style="list-style-type: none">● signal intent to turn
	<ul style="list-style-type: none">● turn steering wheel hard in the direction of the turn
	<ul style="list-style-type: none">● when traffic is clear in both directions, move forward and complete the turn as quickly as possible
	<ul style="list-style-type: none">● do not accelerate until after the turn is completed
	<ul style="list-style-type: none">● and if the turn cannot be completed in one motion, back only as far as necessary for completion of the turnabout
	<p>Turning around by using the right side of the roadway or by backing into a driveway requires a two-lane roadway.</p>

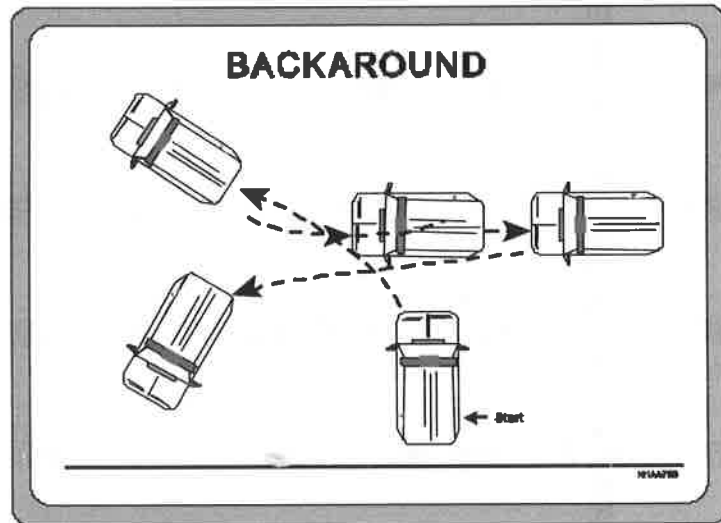

To complete such a backaround--

- use a two-lane roadway
- use the same method as backing into a perpendicular parking space
- check roadway for traffic before and during the maneuver
- avoid driving head-in into a driveway, as this reduces maneuverability when exiting the driveway

Urban Driving

Urban driving can be one of the most challenging experiences an operator will face. In urban traffic, your ambulance is surrounded by others being

driven closer together than is considered safe. Traffic is constantly changing speed, some traffic may be stopped, and vehicles are entering and exiting the traffic flow from all directions.



Our local regulations about urban driving include--



Obviously, you must be at your peak of alertness to safely drive in heavy urban traffic. In order for an ambulance operator to drive a safe emergency response in heavy urban traffic, he must first understand and be able to drive routinely in heavy traffic. Urban driving requires that the operator be observant and learn to fit well within traffic.

When operating in congested city traffic, there are usually a lot of things happening. It is most helpful to have a second pair of eyes assist you. Since the most critical part of your run is getting to the patient and your primary duty is to drive the ambulance safely, have the EMT sit in the passenger seat to help navigate and watch the traffic.

The EMT may also use the radio to request alternate routes from dispatch should you run into stopped traffic or unforecasted road repairs.

When it is not possible to have two people in the cab of the ambulance, slow down and always look twice. This is critical when proceeding

through busy intersections.

Large buildings will limit visibility at intersections. Large buildings also limit the range of your siren and confuse people about which direction the siren is coming. Your siren may get lost in all the other city noises unless you change modes often, such as from wail to yelp.

In urban settings--

- be alert for traffic entering the roadway from alleys, parking lots, driveways, and intersections
- be alert for children playing in the streets, people exiting delivery vehicles, drivers opening doors to exit parked vehicles, bicyclists, and pedestrians at school crossings and crosswalks

Rural Driving



Our local regulations about rural driving include--



- Be alert for loose livestock and pets.

- Be alert for bicyclists, school buses, and children waiting for buses.

- At the higher speeds of driving in rural areas, drivers may have their windows up and the radio on and will not be able to hear the siren until you are close to them.

- Be alert for slow-moving vehicles, such as tractors, farm equipment, trucks, and horses and buggies.

Two-lane Highway Driving

Two-lane highways are dangerous because it is difficult to maneuver around other vehicles, making you contend with slower traffic. Do not take unwarranted chances in the hopes of getting to your destination faster. Studies have shown that the chances taken are not worth the few seconds saved by passing a slower vehicle.



Our local regulations concerning two-lane highway driving include--



Remain calm and patient and allow the other drivers sufficient time to slow and pull over so that you may pass without endangering yourself, your passengers, or the other drivers.

Highway/interstate Highway Driving

The special challenges of highway or interstate driving are directly related to the increased number of vehicles on the road and the increased speed of those vehicles.



Our local regulations about interstate highway driving include--



Use the 12-second rule to constantly read the subtle changes that occur in traffic.

Prerun route planning, which is covered in Lesson 6, means not only picking a route but knowing the route, including the corners where you will turn and the exits you will take off the interstate road. Sudden moves, such as quickly changing lanes to get to an approaching exit or the reflex to brake after you miss an exit, are the cause of many interstate crashes. Know the exit you're supposed to take by at least one exit preceding it.

Be aware of how other drivers may respond to the emergency vehicle.

When exiting an interstate roadway, maintain your present speed until your ambulance is completely off the interstate and use the exit ramp for

decelerating. Remember that shorter ramps will require a greater rate of deceleration.

When entering an interstate roadway, use the entrance ramp to accelerate to the speed of traffic. Once on the interstate, progress lane by lane to the extreme left or "fast" lane. The siren should be in the yelp mode when making lane changes as this promotes vehicle recognition.

Use extreme caution while on the interstate. Most people mean well and are really trying to clear the path for your vehicle. A little patience will help keep you in good stead with the public and out of potential crash situations.







About how much distance must there be between my vehicle and an oncoming vehicle if I want to pass a slower vehicle at 55 mph on a two-lane road?





The best way to back the ambulance is with the aid of what?



	<p>Why don't I want to lock the brakes in an emergency situation?</p>
	<hr/> <hr/> <hr/> <hr/> <hr/>
	<p>Perpendicular parking is best performed by which: backing in or driving forward into the spot?</p>
	<hr/> <hr/> <hr/> <hr/>
	<p>The 12 second rule should only be used on the highway because you can't see 12 seconds ahead when driving in a city. True or false, and why?</p>

	<hr/> <hr/> <hr/> <hr/> <hr/>
---	-------------------------------

**POINTS TO
REMEMBER**

Road construction and engineering factors affect ambulance control and quality of ride. Some of the factors to be considered are--

- different types of road surfaces and the transition between road surfaces
- road conditions and roadside engineering
- design of curves
- road crown
- water drainage

The four driving skills which effect the quality of ride are--

- cornering
- braking
- accelerating
- maintaining appropriate speed

You maintain a safety cushion around the ambulance by--

- encouraging tailgaters to pass
- making the public aware of the existence of multiple responding units
- driving defensively
- communicating with the other drivers on the road

Basic maneuvers you perform every day include--





- braking and stopping
- making lane changes
- passing on two lane roads and passing stopped traffic
- backing
- parking
- turning

You must be accomplished in driving on all road types and for all road conditions that you may encounter in your area.

COURSE:	EMERGENCY VEHICLE OPERATOR COURSE (AMBULANCE): NATIONAL STANDARD CURRICULUM
MODULE A:	Ambulance Operation: The Basics
LESSON 8:	Operations in Emergency Mode and Unusual Situations
COURSE GOAL:	To provide ambulance operators with the knowledge and skills to operate their vehicles so that their vehicle, equipment, crew, and patients will be delivered safely and efficiently and the safety of the public will be assured during all phases of the delivery of the Emergency Medical Services (EMS) involving the ambulance
MODULE GOAL:	To provide ambulance operators with the knowledge required to safely and efficiently operate an ambulance in both non-emergency and emergency modes

<p>LESSON GOAL:</p>	<p>To provide participants with knowledge of how to operate an ambulance under emergency driving and other high risk driving situations in order to reduce ambulance crashes</p>
<p>PERFORMANCE OBJECTIVE(S):</p>	<ul style="list-style-type: none">● For each emergency driving situation presented, select the recommended procedure to be followed when driving an ambulance● Identify the problem(s) associated with each adverse driving condition listed● For each adverse driving condition listed, select the recommended procedure to be followed when driving an ambulance● For each driving scenario listed, select the recommended crash avoidance technique to be followed when driving an ambulance● For each driving scenario listed, select the recommended vehicle recovery technique to be followed when driving an ambulance

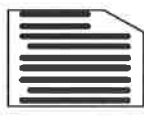
PM APPENDIX:	
PARTICIPANT MATERIALS:	

ICON LEGEND			
			
Notes	Response	Appendix	Local Requirements

INTRODUCTION

EMERGENCY DRIVING

What is "emergency driving"?

The emergency mode of ambulance operation is specifically defined by each individual state and refers to the use of emergency vehicles, equipment, and operations. Emergency driving, in general, is defined as using clearly defined procedures in the operation of an ambulance when responding to a medical emergency, including the use of emergency signaling devices, such as lights and siren.

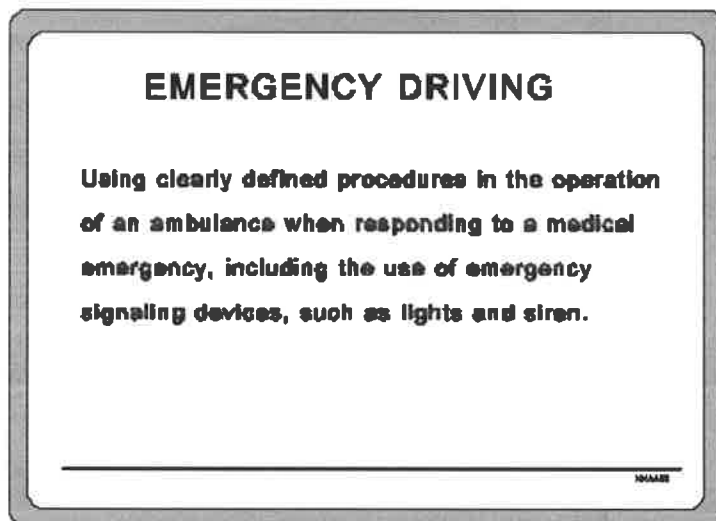

Emergency ambulance driving and high-speed driving are two distinctly different activities. High-speed driving is dangerous for the patient, the crew, and everyone else on the road.

When responding to a medical emergency, follow the state statutes concerning speed, but it is best to stay within the posted speed limit.

Emergency Signaling Devices

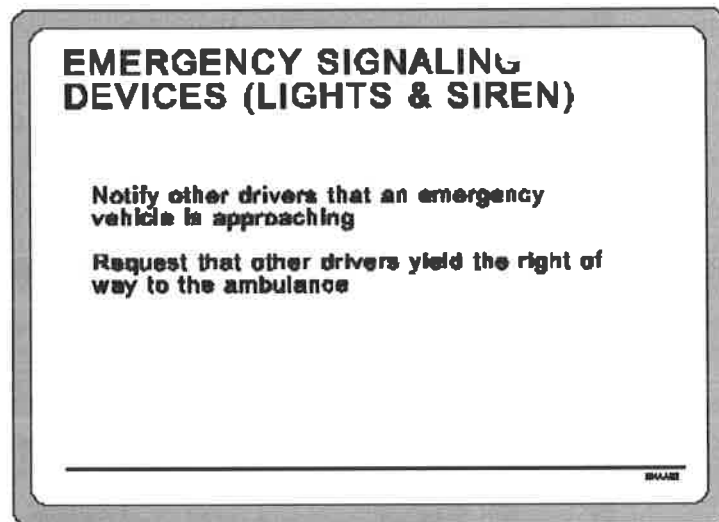

Emergency signaling devices (lights and siren) are used during emergency driving for two reasons:

- to notify other drivers that an emergency vehicle is approaching
- to request that the other drivers yield the right of way to the ambulance

Other Drivers' Response to Emergency Driving

Most drivers will yield the right of way to an ambulance if--

- they realize the ambulance is there
- they have sufficient time to make a decision as to what to do
- they have sufficient time and space to carry out that decision

The use of the emergency lights and siren cannot guarantee safe, clear passage. While most drivers will yield the right of way, some won't be able to see and/or hear the ambulance because of visibility restrictions in their vehicle or because of other noise or radio interference. And some drivers, even though they see and hear the ambulance, will refuse to yield the right of way.

The use of lights and siren actually increases your danger of a crash.

Response Time

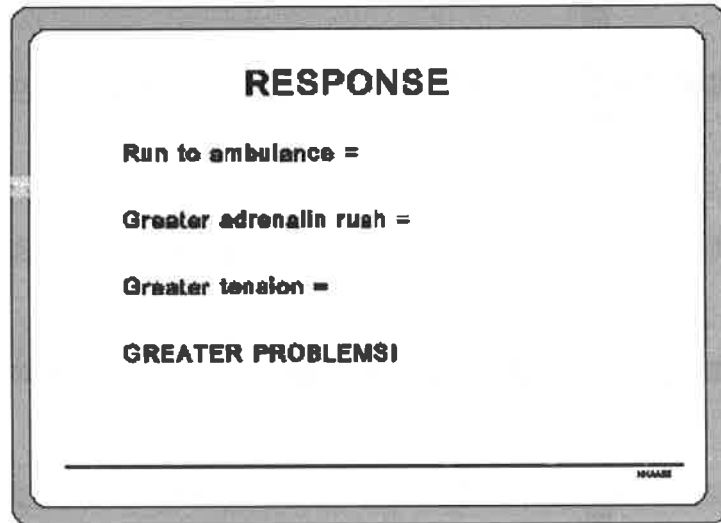

While there is a need to respond to an emergency as quickly and efficiently as possible, some time-saving methods can have harmful effects and, in the majority of cases, the few minutes saved will probably not matter.

Speed Limits

Speed limits are based on the quality of the road and the normal traffic conditions. Traffic conditions do not remain normal when an ambulance approaches.

A study by the Society of Automotive Engineers indicates that sirens warn pedestrians and the drivers of vehicles traveling in the same direction and ahead of the ambulance. Sirens do not give sufficient warning to drivers of vehicles approaching head on, or traveling on converging roads.

In a rural environment, a person in a closed car proceeding at 55 miles per

hour (mph), with the radio playing, may not be aware of a penetrating electronic siren (wail) until it is as close as 33 feet away. In city traffic, a driver with the car windows open and no radio playing might not detect the siren more than 123 feet away.

The effectiveness of the siren warning system to vehicles on crossroads is only about one-third of that for a vehicle straight ahead of the siren and traveling in the same direction.



Even when operating in the emergency mode, follow the state statutes concerning speed, but it is best to stay within the posted speed limit.



The local regulations governing the use of lights and siren are--



Controlled Intersection Procedure



What is a "controlled intersection?"



Dangers

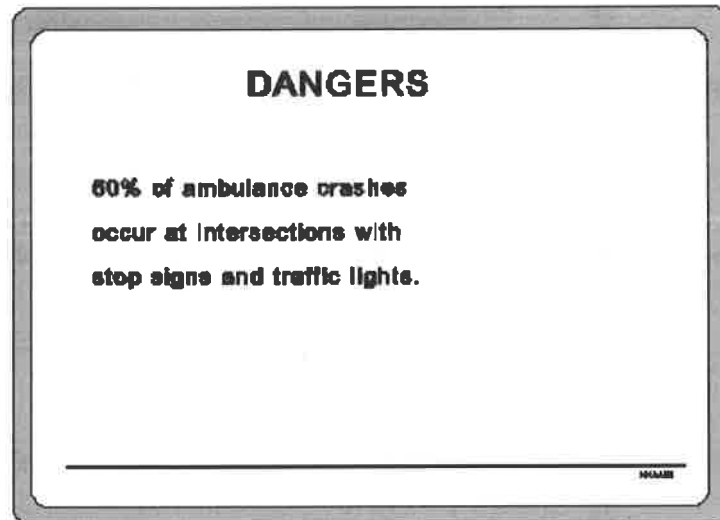

The New York State Department of Health reported in the "Ambulance Accident Prevention Seminar" that 60 percent of ambulance crashes occur at intersections with stop signs or traffic lights.



If the intersection is controlled, why would ambulances have so many crashes?





At an intersection controlled with stop lights, who has the right of way, the approaching ambulance or the cars with the green light?



Due Regard

LAW OF DUE REGARD

**A reasonably careful person,
performing similar duties and
under similar circumstances,
would act in the same manner.**

The Law of Due Regard says that "a reasonably careful person, performing similar duties and under similar circumstances, would act in the same manner."

The Law of Due Regard requires that the courts look at each crash and determine if the ambulance operator was abiding by the law of due regard at the time a traffic crash occurred. To do so, they must get answers to questions like the following:

- Was it necessary to use the emergency warning system under the circumstances of the call you were responding to and the medical condition of the patient you were transporting?
- Did the ambulance operator give enough warning of the vehicle's approach to allow other motorists and pedestrians to clear the way for the emergency vehicle?

- Was the emergency warning system activated and operating prior to the crash?

- Was the ambulance operator using the emergency warning system in the manner for which the system was designed to be used?

- Was the operator of the ambulance operating the vehicle at a speed greater than necessary to allow the complete control of the ambulance in relation to traffic, road, and weather conditions?

Your performance as the operator is going to be closely looked at in relation to the nature of the emergency and the traffic, road, and weather conditions.

The National Voluntary Consensus Standard

The standards have used the ASTM guideline as a reference. The standards for controlled intersection management during emergency response mode are--

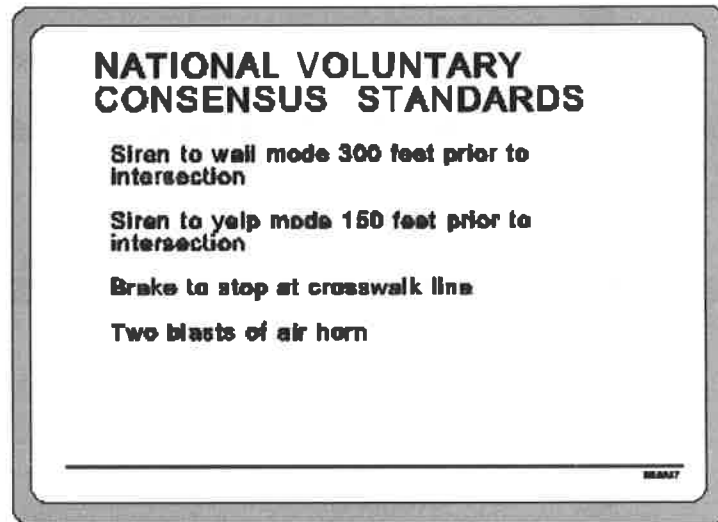

- The siren should be in the wail mode 300 feet prior to the intersection.
- Switch the siren to the yelp mode 150 feet prior to the intersection.
- Remove your foot from the accelerator to cover the brake pedal and allow compression to slow the vehicle. Start applying the brake to bring the ambulance to a complete stop at the crosswalk line.
- If the ambulance has an air-driven airhorn, give two short blasts on the airhorn.

NATIONAL VOLUNTARY CONSENSUS STANDARDS

Stop, look, make eye contact, proceed.

**Continue yelp mode, proceed with
highest degree of care.**

Clear each lane prior to crossing.

**Anticipate vehicles entering from
right and left.**

- **Make a complete stop.** Look to the left, look to the immediate front, look to the right, and then again to the left. You may then proceed through the intersection under 10 mph if traffic is stopped in all lanes to the left, in front of and to the right of the ambulance. After you have made eye contact with all stopped vehicle drivers, you may proceed through the intersection exercising the highest degree of care.
- Continue with the siren in yelp mode and proceed through the intersection exercising the highest degree of care.
- When there are vacant lanes to the left or right, you must complete the previous steps of clearing each lane of traffic prior to crossing that lane.
- You should expect that any vacant lane to your left or right may become occupied by another vehicle which did not see or hear the ambulance's warning systems.

**NATIONAL VOLUNTARY
CONSENSUS STANDARDS**

Anticipate multiple responding units.

Avoid passing stopped vehicles on the right.

Turn right after drivers on the right are aware of ambulance.

Anticipate left turns in front of ambulance by oncoming traffic.

Beware of other intersection hazards.

- You should be aware that other emergency vehicles may be approaching the same intersection that you have taken control of. You should not enter the intersection until the other vehicles have stopped or proceeded through the intersection.
- You should avoid passing stopped vehicles on their right.
- You should turn right at the intersection only after all vehicles have stopped and drivers on the right are aware of the ambulance.
- You should expect that any vehicles in front may make an unexpected left turn in front of the ambulance after it has started to enter the intersection.
- You must be aware of other hazards at the intersection, for example, pedestrians, road hazards, defective traffic control systems.



The local rules for driving through controlled intersections are:





Typical local intersection--



Dangerous intersections--

Driving Against Traffic

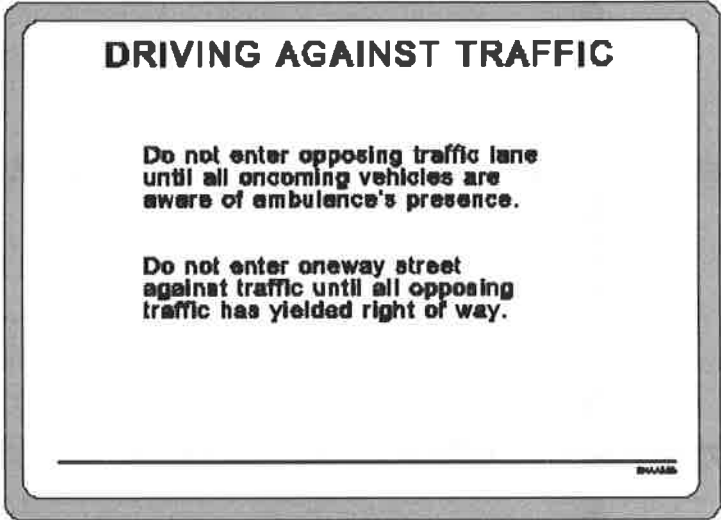

On a multilane highway, do not enter an opposing traffic lane until it is safe to do so and all other oncoming vehicles are aware of the ambulance's presence.

Similarly, do not enter a one-way street against traffic until all opposing traffic is aware of the ambulance's presence and has yielded the right of way.





Our state and local criteria for driving against traffic includes--



 There are two reasons why we use emergency signaling devices. What are they?

 _____

 You are in the emergency response mode and are driving to the scene of a multiple-car crash. The weather conditions are good, traffic is light, and the speed limit is 55 mph. What is the maximum speed you may drive?

 _____

 Three hundred feet prior to approaching a controlled intersection, your siren should be in which mode? And, 150 feet prior to the intersection, change the siren to which mode?

 _____



Prior to entering a one-way street against traffic, what must you do?



After coming to a complete stop for a red light at a controlled intersection, what must the operator do prior to proceeding through the intersection?

ADVERSE CONDITIONS

One of your goals is to provide a smooth, uneventful ride for your patient, not the fastest ride possible.

Smooth driving keeps the ambulance balanced. When the ambulance is balanced, its weight is distributed evenly to all four wheels, the suspension is stable, and steering and braking are most effective.

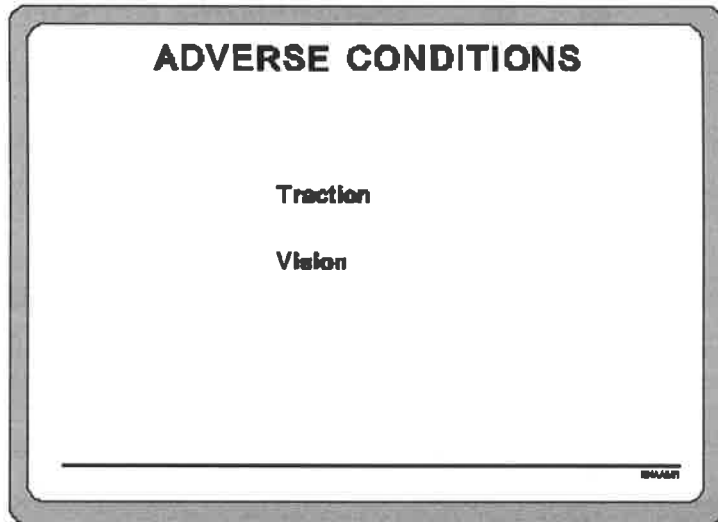

Adverse conditions affect--

- Traction
- Vision

Conditions Affecting Traction

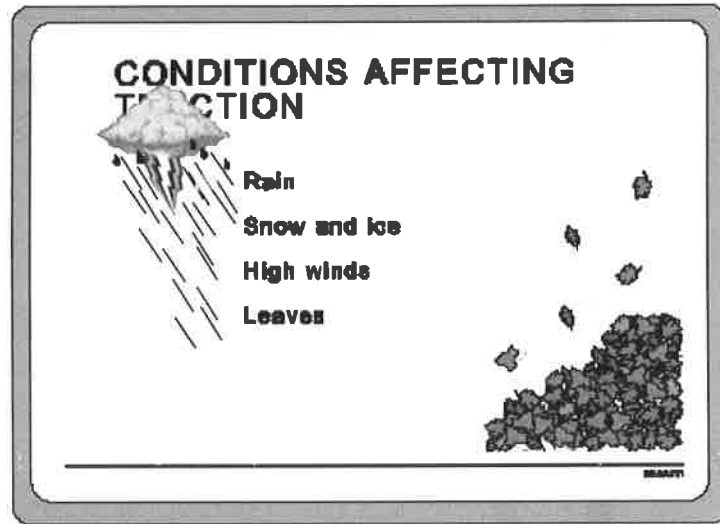

Rain

Rain affects traction in three ways:

- When it rains, a layer of water forms over the road. As a rolling tire moves over this layer of water, it loses contact with the road surface. This is called hydroplaning. Hydroplaning is especially dangerous because you lose steering and braking control. As little as 1/16 of an inch of water on the road surface can cause hydroplaning.
- Driving through large areas of water can affect brake performance because the brakes become wet and less effective.
- If the water is concentrated on one portion of the road and only one side of the vehicle goes through the water, the vehicle will tend to pull in that direction. The force of the pull is dependent on the depth of the water and the speed of the vehicle.

Precautions--

- Slow down before hitting water
- Gently apply your brakes for a few moments as you exit the deeper puddles to heat the brake shoes and dry them

Snow and Ice

Snow and ice form an extremely slick barrier between your tires and the roadway. Extreme caution must be taken when driving on snow and ice to avoid sliding when turning, braking, and accelerating.

Bridges and shaded roadways freeze first.

When driving through deep snow, proceed slowly and shift into a lower gear before entering the snow and attempt to keep the ambulance moving through the snow.

High Winds

The ambulance is very susceptible to the effects of the wind.

Cross-winds can blow the vehicle off the road or across the center line, particularly in curves and corners and especially when it's raining, snowing, or icy and traction with the road is already reduced.

Wind shifts occur as you pass buildings, travel through an underpass, or pass large trucks. Reduce speed to lessen the effects of these wind shifts.

Leaves

Wet leaves on the roadway can become as slick as ice or snow. Slow down and treat them as you would a large patch of ice.

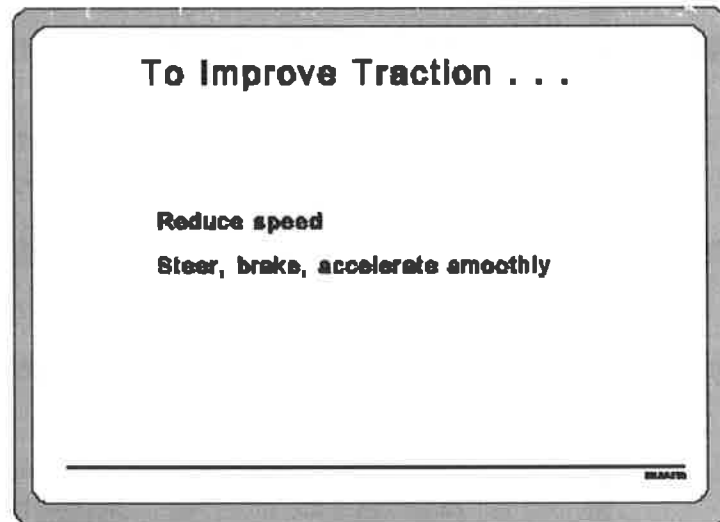

Increasing Traction with Traction Devices

When it starts to rain, retain control by reducing speed and apply smooth steering, braking, and acceleration.

Snow Tires

Snow tires have a tread pattern that is different than normal highway tires.

This open, deeply grooved tread pattern increases the tire's grip on the snow and is designed to clean itself as the tire rotates.

Chains

Chains can be carried in the vehicle and installed when needed. When using chains, reduce your speed to keep them from banging against the ambulance. Chains should be removed before driving on bare roads, if possible.

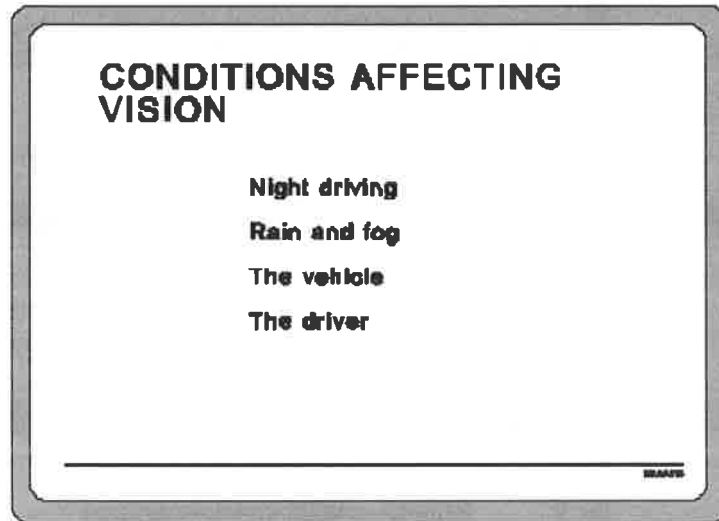

Conditions Affecting Vision

Your vision can be affected in three ways. First, the environment may give you problems. Second, your vehicle and the way you care for it may affect the way you are able to see things. And finally, your physical condition and preparation for duty will affect your eye's ability to see.

	Driving at Night
	Even under the best of weather conditions, visibility is decreased at night. Because there is less light, your eyes work differently, and you see things differently than in the daytime.
	Because of the way your eyes are designed, you have a blind spot in the center of your field of vision. At night, the blind spot may hide small, poorly lit objects if you try to stare at them. To compensate, you must constantly scan the different parts of the area ahead.
	Some other problems you encounter when driving at night are--
	<ul style="list-style-type: none">● Darkness conceals hazards and you must make decisions based on incomplete information.
	<ul style="list-style-type: none">● It is more difficult to judge the speed and position of another vehicle because you do not have distinct shadows and other objects as reference points.
	<ul style="list-style-type: none">● Your peripheral vision is reduced if you smoke. This makes it more difficult to judge the speed and position of other vehicles, especially at night.
	<ul style="list-style-type: none">● Adequate highway lighting is limited.
	<ul style="list-style-type: none">● Glare from roadside lighting and oncoming vehicle headlights impair your visibility.
	Night Driving Techniques

A few night driving techniques can help reduce the dangers:

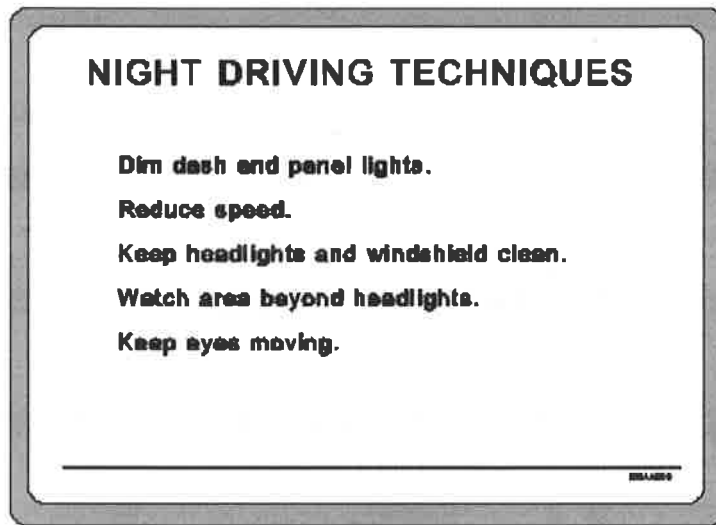

- Keep dash and panel lights dim for better vision, but always have enough light to read the speedometer.
- Reduce speed so that you can stop within the visible distance.
- Increase sight distance by keeping the headlights clean and properly aimed and the windshield clean.
- Watch beyond the headlights on or near the roadway for slow-moving or unlighted vehicles, curves, T-intersections, road obstructions or defects, trains, pedestrians, and animals.
- Keep your eyes moving so that your blind spot does not hide objects ahead.

Maintaining Night Vision

To increase your ability to see at night--

- Don't move immediately from a brightly-lit room to a dark vehicle and begin driving.
- Avoid looking directly into glaring headlights of oncoming vehicles.
- Don't smoke.
- Don't wear sunglasses at night.

Rain and Fog

Rain and fog affect visibility in two ways:

RAIN AND FOG

- Reduce visibility
- Reduce warning capability
- Create glare



- Reduced visibility
- Glare

Use caution in checking outside mirrors when it is raining. Rain can distort or obliterate the images in your mirrors.

The Vehicle



How can your vision be affected by the vehicle?



Windshield/Wipers

Have broken or cracked windshields fixed or replaced, and keep your windshield clean and your wipers operative so that you may clean the windshield.

Visors

Use the visors mounted above the windshield to prevent looking directly into the sun. Move the visors to the side to reduce glare and the hypnotic effect of the sun flashing through trees.

Bug Screens

Plastic bug screens mounted on the front of the hood are very effective in deflecting bugs, and even light rain and snow, up and over the windshield.

Headlights

Keep your headlights clean and operative to provide maximum lighting at night and in adverse weather conditions.

Side View Mirrors

Keep your side view mirrors clean and properly adjusted so that you are able to see to down both sides of the vehicle. If necessary, adjust a mirror slightly to prevent glare when the sun is behind you.

The Driver



What things might you do that affect your own vision?



Compensating for Visibility Problems

COMPENSATING FOR POOR VISIBILITY (1 of 2)

Prepare yourself.

Use low beams and wipers.

Watch for slow or stopped vehicles.

Check rear view mirrors often.





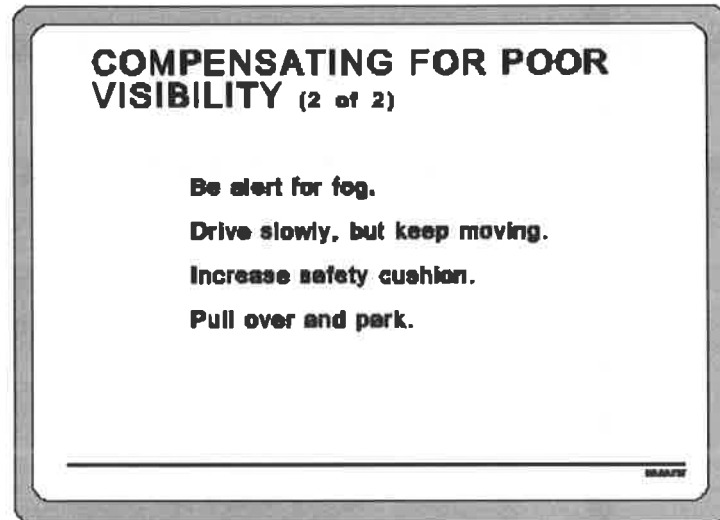

EMERGENCY

These are some additional ways to compensate for visibility problems:

- Prepare yourself.
- Turn on low beam headlights and the wipers, if needed.
- Watch for slow moving and stopped vehicles.
- Check the side view mirrors frequently for vehicles approaching quickly from the rear.



- Be alert for patches of fog in valleys and low-lying areas.
- Drive slowly, but keep moving.
- If conditions are too bad to continue, pull over as far as possible, stop, leave lights on, and activate hazard lights.

	<p>Hydroplaning occurs when it rains and a layer of water forms between the tire and the road surface. Why is hydroplaning dangerous?</p>
	<hr/> <hr/> <hr/> <hr/>
	<p>After it has rained and there are puddles of standing water, how can you reduce the effects of hydroplaning?</p>
	<hr/> <hr/> <hr/> <hr/>
	<p>What is the problem associated with high cross-winds?</p>
	<hr/> <hr/> <hr/> <hr/>
	<p>While on a run at night, you remember from this course that your eyes</p>

	<p>work differently and that you have a blind spot in the center of your field of vision. What do you do to compensate for this blind spot?</p>
	<p>_____</p> <p>_____</p> <p>_____</p>
	<p>What things improve your night vision?</p>
	<p>_____</p> <p>_____</p> <p>_____</p>
<p>CRASH AVOIDANCE TECHNIQUES</p>	
	<p>What is "crash avoidance"?</p>
	<p>_____</p> <p>_____</p> <p>_____</p>

CRASH AVOIDANCE

Drive to keep the ambulance out of a situation where a crash is unavoidable.

Justification

In *Emergency Ambulance Driving*, Childs and Ptacnik point out that one in four drivers will be involved in a major motor vehicle crash.

Crashes don't have to be caused by you. In their panic to get out of your way, other drivers may cause a crash that eventually involves your vehicle.

Techniques

A crash's severity can almost always be lessened if the operator continues to drive the ambulance.

Plan Ahead to Avoid a Crash

Planning ahead for a crash does two things. It physically prepares

your vehicle for the effects of a crash. And, it prepares you mentally by making you think about avoiding the crash.

Securing Your Equipment

Store items in cabinets or tie them down so that they do not become missiles during a crash.

Check your ambulance for items that may come loose and doors or drawers that may open. Try to find ways to fasten them so that they remain closed or tied down when not in use.

Use padding to cushion sharp corners and prevent injury.

Wear Seat Belts

Always wear your seat belts and have your passengers wear theirs.

Keep the patient belted to the stretcher and the stretcher secured to the chassis.

Mentally Prepare Yourself

Plan your escape route from every situation around you.

Decide which item to hit if a crash is unavoidable. You have two choices, but always hit at an angle rather than head-on. Choose to hit items that will absorb the impact rather than solid objects.

Maintain Rear and Side Space Cushion

The further other vehicles are from your ambulance, the more difficult it is to be involved in a crash with them.

Back With a Ground Guide

Use all the help you can to avoid backing into other vehicles or items on the ground. Back with a ground guide.

Multiple Responding Units/Multiple Agency Response

Anticipate other units responding to the same emergency, or to other emergencies in the vicinity. Look out for their lights. Change the volume of your siren so that you can hear the sirens of other units.

Clearing a Controlled Intersection

The only way you can prevent a crash with other drivers at an intersection is to look each driver in the eye and see that they have acknowledged your presence and have agreed to yield the right of way.

Then, and only then, are you safe to proceed toward the next intersection. Or are you? Is there another driver hidden behind that truck beside you or around the corner? Always be alert and never get careless.

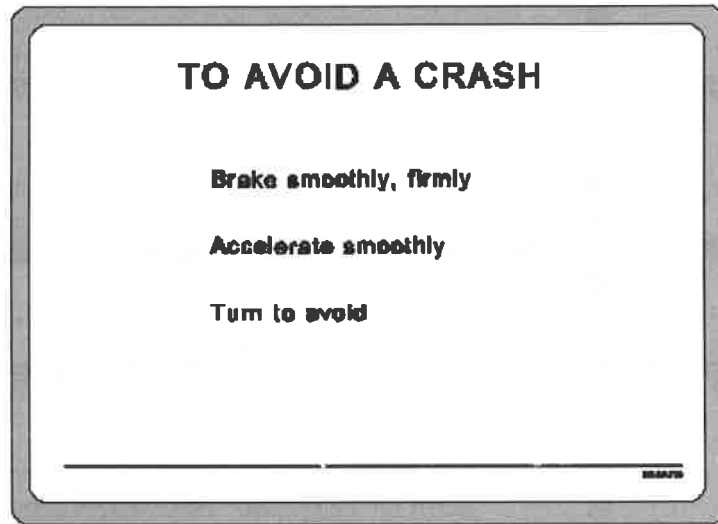

Faced with the certainty of a crash, there are three things a driver can do: brake, accelerate, or turn to avoid it or lessen the impact.

Braking

Braking takes time and distance to be effective. If brakes are required, apply them smoothly and firmly. Do not lock the brakes.

Acceleration

If, when crossing an intersection, you realize that you are about to be hit from the side or rear, you may be able to avoid a crash by accelerating as smoothly and rapidly as possible without spinning the wheels.

Steering Out of the Way

There are many times where steering out of the way is the only way to avoid a crash. To do so, the vehicle must be moved sideways as far as required and as quickly as possible to clear the hazard. Even if you only partially clear the object, you will hit it with a glancing blow instead of head-on.

Practice driving with your hands at the ten and two o'clock or nine and three o'clock positions so that you are always prepared to execute a smooth, but rapid, turn.







What are some of the things you can do to mentally prepare yourself to avoid a crash?





Sometimes, despite all the planning you do, crashes happen. Faced with the certainty of a crash, there are three things a driver can do. What are they?



	<hr/> <hr/>
	<p>As you are moving through a controlled intersection, you suddenly notice a car moving rapidly toward you from your left side. What is probably the best way to avoid a crash?</p>
	<hr/> <hr/> <hr/> <hr/>
	<p>You are driving down the interstate in the left lane doing 55 mph. All the traffic has been responsive to your lights and siren and have moved into the right lane. Suddenly, a car ahead pulls from the right lane into your lane right in front of you. What two things can you do to avoid the crash?</p>
	<hr/> <hr/> <hr/> <hr/>
	<p>You have been parked at the crash scene for 20 minutes. As you get ready to leave, you notice that other vehicles have blocked you from driving forward. Prior to backing out of your parking spot, what should you do to help you avoid colliding with equipment behind your ambulance?</p>



VEHICLE RECOVERY TECHNIQUES

Sometimes, you may be able to avoid a crash by driving off the road, or, for some reason you have driven off the road and need to recover by returning to the road without causing a crash. At other times, you may have a vehicle malfunction and you need to respond to the malfunction and then safely pull off the road.

Running Off the Road Recovery Techniques

OFF ROAD RECOVERY

- Remove foot from accelerator**
- Continue to drive**
- Slow and regain control**
- Signal intentions**
- Pull back onto the road**

Initial Reaction

The most common reaction when leaving the road surface is to quickly try to get back onto the road. This reaction frequently causes a head-on crash because you overcorrect and cross the center line into the oncoming lane.

Control

To avoid over-correcting, immediately remove your foot from the accelerator and continue to drive the ambulance. Do not brake heavily or you may be pulled further from the road. If no obstacles are directly ahead, continue to slow and regain steering control in preparation for pulling back onto the road.

Pulling Back Onto the Road

Check your side view mirrors and signal drivers behind you that you plan to return to the road. Smoothly turn the steering wheel and drive back onto the road.

In the event an additional hazard (such as a pole or guard rail) is directly ahead on the shoulder of the road, you may have to drive immediately back onto the road, even though you may not be fully prepared.

To do so, smoothly turn the steering wheel toward the road and then immediately straighten it as the front tire makes contact with the edge of the roadway. The brief period between the steering input and the resulting action should allow the rear tire to also climb onto the road. This rapid maneuver will allow the steering to be corrected before the ambulance is driven into oncoming traffic.

Responding to Vehicle Malfunction

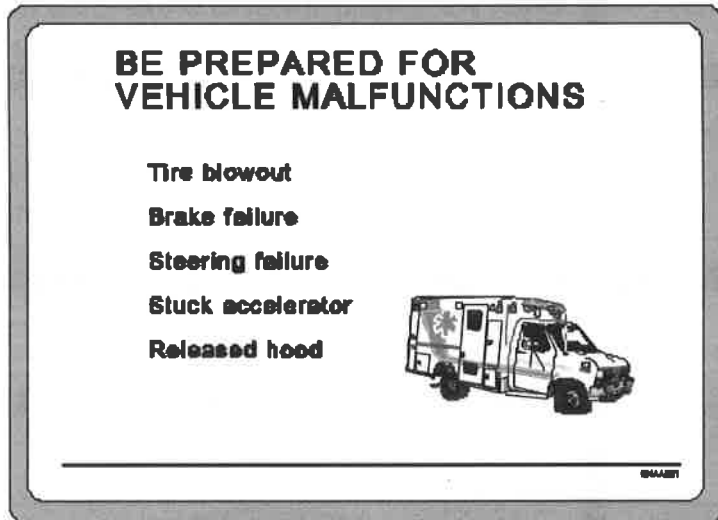

Tire Blowout

If a front tire blows out, the vehicle immediately swerves in the direction of the destroyed tire. If a rear tire is involved, the back of the vehicle sways back and forth.

In either situation, hold the steering wheel firmly and steer enough to maintain your lane position. Ease off the accelerator, but do not brake. Rapid deceleration or braking may make steering control more difficult.

Once speed has been reduced to the point where you can steer, slowly begin braking, signal your intentions, and move off to the side of the road.

Brake Failure

If brake failure occurs, try the brakes again. If pumping the brakes does

not work, shift into a lower gear and use the engine to brake. Carefully apply the parking brakes. The parking brakes only work on the rear brakes and stopping distances will be much longer. Continue to steer and maneuver to where you can safely leave the road.

If brake failure occurs while going down a hill and engine braking and use of the parking brake are not effective, you may have to sideswipe parked cars, guard rails, small trees, or dirt banks to slow sufficiently.

Steering Failure

Today's ambulances are equipped with power steering. In these vehicles, steering failure occurs whenever the engine quits. It may also occur if all power steering fluid is lost. In either case, the ambulance can still be steered, but it will take more physical strength since the operator has to overcome the failure of the hydraulic system.

If steering failure occurs, slow the vehicle and pull off the road. Do not brake heavily in case the vehicle pulls to one side; you do not have the strength to overcome this extra force.

Stuck Accelerator

Shift the transmission into neutral and get the vehicle off the road and stopped as quickly as possible. Understand though, that once the resistance of the drive train is released by the transmission, the engine will rev up quickly. If the engine is not shut off quickly, it will probably fail, resulting in the loss of steering control and brakes.

Released Hood

If the hood releases and breaks your vision, try to find a small gap through which you can look at the base of the hood and pull the ambulance off the road. If all forward visibility is blocked, quickly get your head out the side window and drive the vehicle to the side of the road and stop.

Techniques for Pulling Off the Road

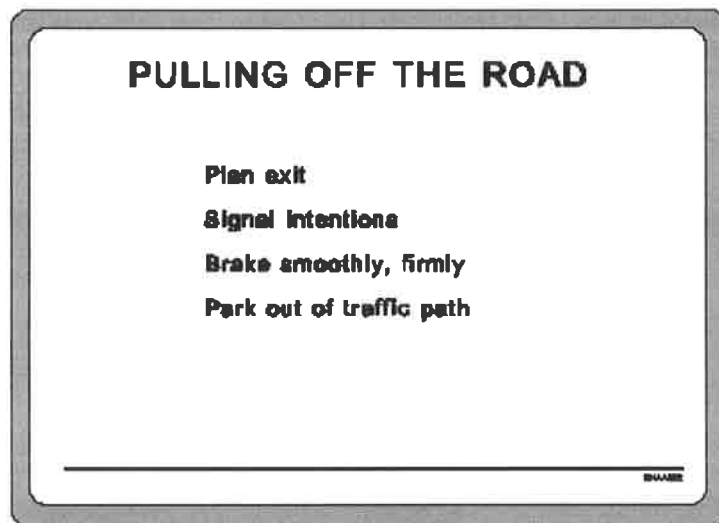





Planning

Plan your exit with the time available. Signal your intentions and use the first available parking area.

Braking

Most vehicle malfunctions require rapid deceleration. Remove your foot from the accelerator and begin smooth, firm braking. You may have to release some of the braking pressure if it becomes difficult to control the

	<p>steering. Continue to drive the ambulance and do not just jam on the brakes.</p>
	<p>Parking</p>
	<p>Once you have driven off the roadway, stop the ambulance where it will not be hit by other traffic. Turn on your emergency flashers and turn off your emergency lights and siren.</p>
	<p>As you are taking a patient to the medical facility, you hit a deep pothole and your left front tire blows out. How should you recover?</p>
	<p>_____</p> <p>_____</p> <p>_____</p>
	<p>After stopping and visually clearing a controlled intersection, you accelerate normally and begin a right turn toward the medical facility. You notice that it is taking a lot of effort to turn the steering wheel. What is the probable failure and what do you do to recover?</p>
	<p>_____</p> <p>_____</p> <p>_____</p>
	<p>You are on a run in the country on a two lane asphalt road and notice that the farm tractor coming toward you is wider than normal and is crowding</p>

the center line. As you pull to the right to avoid hitting the tractor, your right wheels run off the hard surface onto the soft shoulder and you feel the ambulance pull hard to the right. What should you do to recover?





If, in the previous situation, you saw a car parked on the edge of the road just ahead of where you came off the road, what procedures would you use to quickly pull back onto the road?



**POINTS TO
REMEMBER**

In the emergency mode you use emergency signaling devices while responding to a true medical emergency. Even in the emergency mode, you should not exceed the posted speed limit. Safe, controlled driving will get you to the emergency scene and the medical facility without endangering you, your crew, or the patient

Emergency signaling devices are used during emergency driving--

- to notify other drivers that an emergency vehicle is approaching
- to request that the other drivers yield the right of way to the ambulance

When approaching other drivers with your lights and siren on, always expect the unexpected.

The controlled intersection is the most dangerous part of any run. Approach each intersection slowly and carefully, and thoroughly ensure that you have the right of way before proceeding through the intersection.

Adverse weather conditions affect traction and vision. To improve traction, slow down. To improve vision, make sure windshield and mirrors are clean. To improve performance, make sure that you are well rested and not under the influence of drugs or alcohol.

When faced with an impending crash, try to avoid the crash by braking, accelerating, or steering. Before a crash occurs, prepare your vehicle and prepare yourself.





The Law of Due Regard puts the burden on you to ensure that your actions are necessary and appropriate for the situation.

COURSE:	EMERGENCY VEHICLE OPERATOR COURSE (AMBULANCE): NATIONAL STANDARD CURRICULUM
MODULE A:	Ambulance Operations: The Basics
LESSON 9:	Safety: Special Considerations
COURSE GOAL:	To provide ambulance operators with the knowledge and skills to operate their vehicles so that their vehicle, equipment, crew, and patients will be delivered safely and efficiently and the safety of the public will be assured during all phases of the delivery of the Emergency Medical Services (EMS) involving the ambulance
MODULE GOAL:	To provide ambulance operators with the knowledge required to safely and efficiently operate an ambulance in both nonemergency and emergency modes
LESSON GOAL:	To provide participants with knowledge of safety requirements and how to comply with them while operating the ambulance
PERFORMANCE OBJECTIVE(S):	<ul style="list-style-type: none"> Σ Identify obligations for ensuring passenger safety Σ Identify responsibilities for ensuring safety of the patient's family

	<p>Σ Identify activities for protecting the vehicle and crew at the scene</p> <p>Σ Identify requirements for handling ambulance fires</p>
--	---

PM APPENDIX:	
---------------------	--

PARTICIPANT MATERIALS:	
-------------------------------	--

ICON LEGEND			
			
Notes	Response	Appendix	Local Requirements

INTRODUCTION

The safety of the passengers, crew, and vehicle are your responsibility. This lesson will provide you with the information you need to protect them from potential dangers.

PASSENGER SAFETY

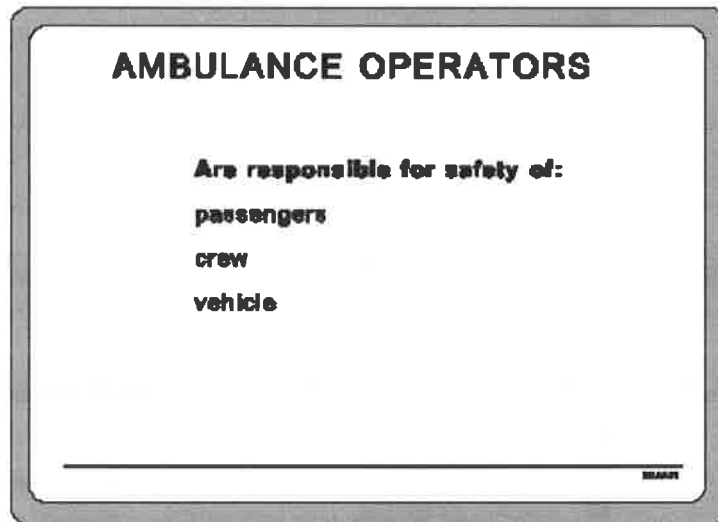

As the ambulance operator, you are responsible for the safety of all passengers in the vehicle. This includes making sure restraints are being used properly, that all equipment and other objects have been secured, and that only safe behavior is tolerated within the vehicle.

Restraints

All passengers--the crew, patients, and operator--must wear a seat belt when the vehicle is motion.

- All passengers must wear a seat belt.

- A child must be properly restrained in a safety seat.
- All patients must be properly secured.

Only the medical technician is exempt from wearing restraints and only when attending to the patient in the patient compartment.

Secure Equipment

Secure all equipment in the operator and patient compartments to prevent an injury if the vehicle has to suddenly stop or swerve. When leaving the scene, all equipment used on the scene should be secured in the vehicle. This includes such things as clipboards, portable radios, and flashlights. If any of the patient's personal effects are being transported, be sure they are properly secured.







Unsafe Behavior

While the vehicle is in motion, if you notice unsafe behavior in the ambulance, it is your responsibility to stop it. If someone is interfering with patient care or vehicle operation, demand that it stops.



Who must wear restraints?



	<p>Why should all equipment be secure?</p>
	<hr/> <hr/> <hr/> <hr/>
	<p>What are some examples of unsafe behavior?</p>
	<hr/> <hr/> <hr/> <hr/>
	<p>What should you do if you notice unsafe behavior in the vehicle?</p>
	<hr/> <hr/> <hr/> <hr/>
	<p>PATIENT'S FAMILY</p>

RESPONSIBILITY FOR FAMILIES OF PATIENTS

May Include:
transporting
ensuring safety
communicating information



BLAKE

Often the family of a patient will be at the emergency scene. Your responsibilities to the family may include--

- transporting them
- ensuring their safety
- communicating certain information to them



When to Transport





Safety As Passengers



Guidelines for Following the Ambulance





If a family member is going to the medical facility in another vehicle, explain where you will be taking the patient and why you will or will not be using the emergency warning devices. If you will be transporting in the emergency mode, be sure to tell the family NOT to try to follow the ambulance. Tell them they must obey all traffic laws.

If the family does not know the area or where the medical facility is, briefly give them directions. If you won't be transporting in emergency mode, suggest that they follow you to the medical facility.



When is it appropriate to transport members of the patient's family?



	<p>What should you do to ensure the safety of a family member traveling in the ambulance?</p>
	<hr/> <hr/> <hr/> <hr/>
	<p>What information should you give a family member who is traveling to the medical facility in another vehicle?</p>
	<hr/> <hr/> <hr/> <hr/>
<p>SAFETY ON SCENE</p>	
<p>To ensure the safety of the crew and ambulance while on scene, you should--</p> <ul style="list-style-type: none">● look for dangers when approaching the scene● be aware of other emergency vehicles/services● be aware of problems improper placement of the ambulance can create● know the correct way to use warning devices to protect the crew, patient, and vehicle from danger while at the scene	

Potential Dangers

Protect the ambulance and crew from potential dangers. Potential dangers you may encounter include--

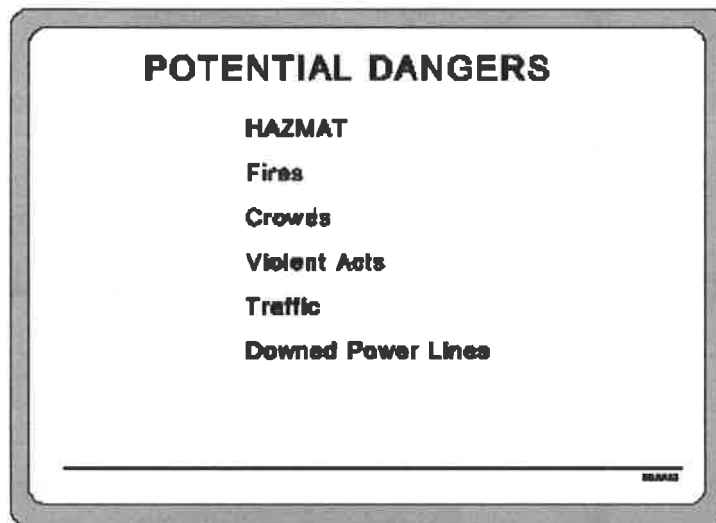

Hazardous Materials (HAZMAT)

Signs of HAZMAT dangers may include spills, fumes, and noxious gases. Be especially aware of hazardous materials when you are responding to a tractor-trailer crash, train derailment, industrial incident, and certain farm incidents. Properly trained and equipped personnel should assess the scene before you enter a possible HAZMAT area. Call for the help you need.

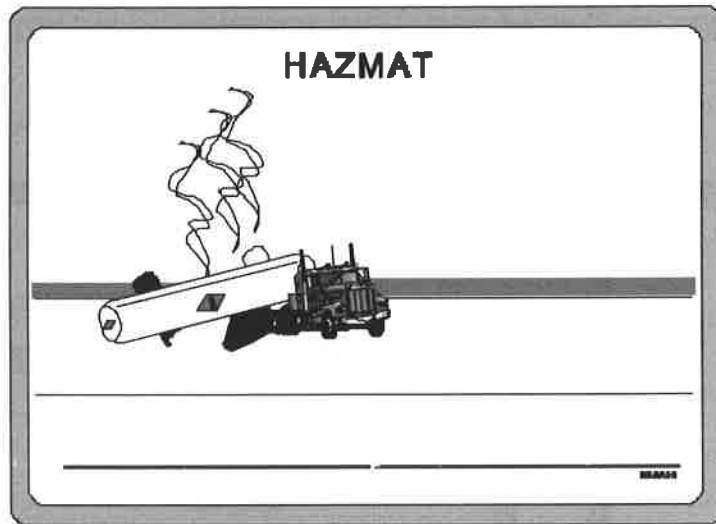

The standard operating procedures for responding to HAZMAT calls are--



Four horizontal lines for writing notes.

Fires

Approach the scene of a fire very slowly. Avoid driving into a wet area; the liquid may be flammable. Also avoid driving over hoses. If smoke clouds are present, be cautious; they may contain lethal, toxic gases. Coordinate your efforts with fire fighters, but allow the trained fire fighters to fight the fire. Call for help if you need it.

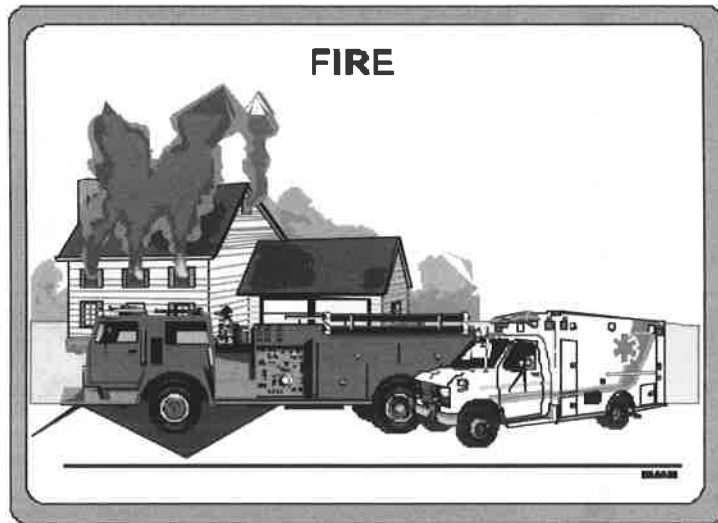

Crowds

When approaching a scene where a crowd has gathered, use extreme caution. People, recognizing you as "help," may run to the ambulance in a panicked state, placing themselves in danger. Crowds can also become hostile to EMS operators. Be sure you are safe. When in doubt, wait on the law enforcement officers to arrive. Allow law enforcement or a scene commander to control crowds. If necessary, call for help.

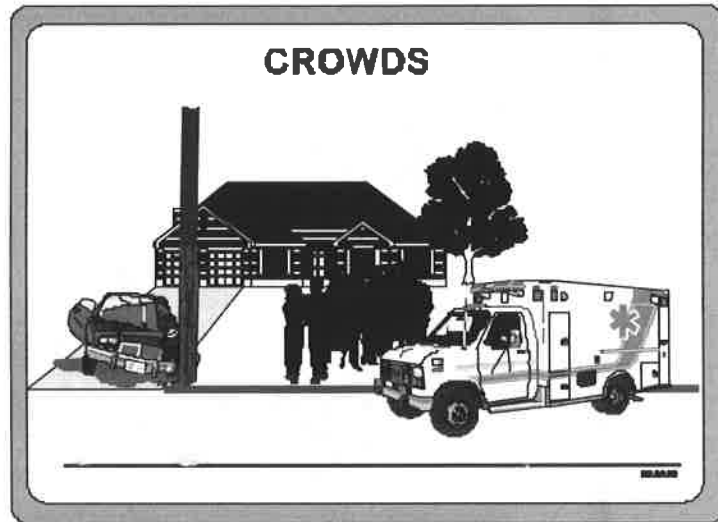

Violent Acts

There may be times when an emergency call concerns a violent situation. Let law enforcement personnel deal with violent or hostile persons and do not hesitate to call for help if needed. Make sure that the vehicle remains secure and attended and out of range of gun fire and other violence. Work closely with the law enforcement officer to safely treat and load patients in the ambulance.

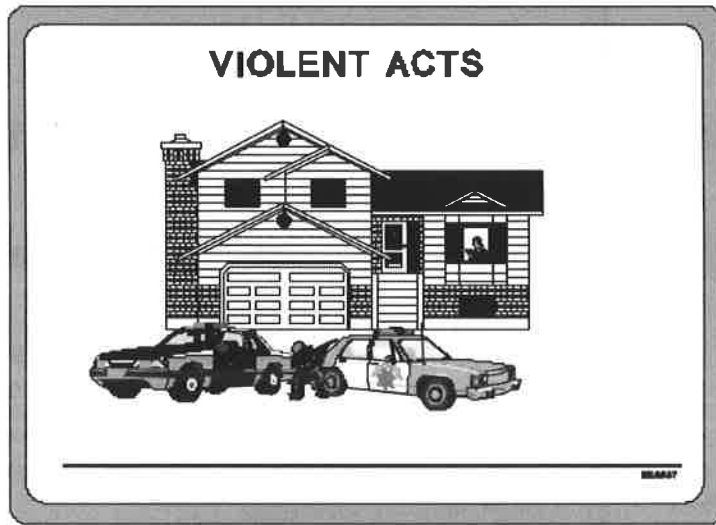

Traffic

The ambulance must be parked away from the flow of traffic in order to protect the crew, patient, and vehicle. (Vehicle placement will be discussed later in this lesson.) Remember that curious drivers often pay more attention to the incident than to their driving. If a reckless motorist disables your ambulance, then you will be unable to transport the patient. Allow law enforcement personnel or scene commander to divert traffic. If needed, call for help. The standard operating procedure will provide guidance if you are the only one on the scene.



The standard operating procedures for diverting traffic are-



Downed Power Lines

Power lines that are down or hanging precariously are very dangerous; only trained personnel should try to remove them. Do NOT touch power lines. A danger zone should be made so that everyone at the scene realizes the danger. Power lines may arc and jump, so make the safety zone far enough away for protection

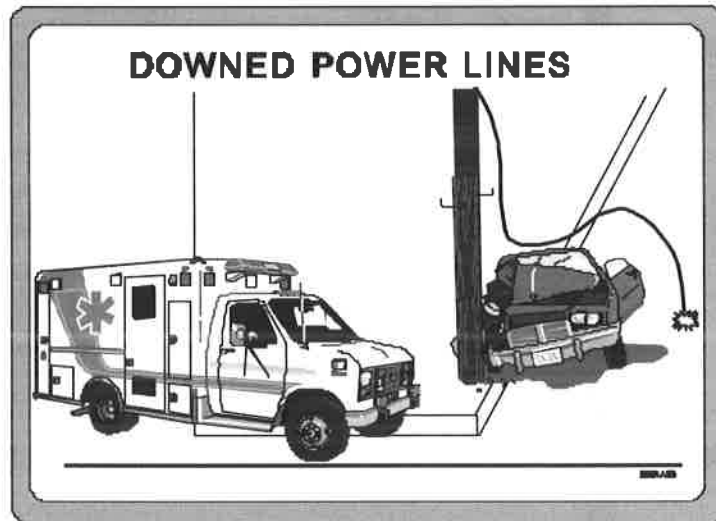

Break up into groups of two or three. Read each of the following scenarios and discuss how you should react to each. Have someone write down your answers. When you are finished, we will discuss your answers will be discussed as a class.

Scenario 1



You are approaching the scene where the injuries have been caused by a gang fight. You are first to arrive on the scene. What should you do?



Scenario 2



You are approaching an emergency scene where a large crowd has formed. What should you do?



Scenario 3



You are approaching an emergency scene where a tanker truck marked with a HAZMAT symbol has been in a wreck. What should you do?



Vehicle Placement

When you arrive at the emergency scene, your first instinct may be to park the vehicle in the first available open area and abandon it to assist with patient care. This practice may lead to more problems and delays because access to the ambulance and equipment may become dangerous and/or lengthy. There are four issues to consider for vehicle placement at the emergency scene. They are--safety, traffic flow, ease of departure, distance from patient.



Safety

Safety includes not only the safety of the ambulance but also the safety of

the crew. Ambulance and crew safety can be affected by restricted access to the ambulance, using the ambulance for scene protection, and various danger zones.

Access

The safety of the crew when accessing the vehicle and the equipment housed in the vehicle is an important consideration for vehicle placement. If one or two sides of the vehicle are along the flow of traffic it will be dangerous for crew members to get to the materials needed for patient care. Park where access to all compartments is out of dangerous traffic flow. Be aware of obstacles such as guard rails and bushes which may restrict access to parts of the vehicle if you park too close to them.

Scene Protection

To keep the vehicle out of traffic flow, it should not be used for scene protection. The ambulance is needed for patient transport and carries essential patient care equipment. Therefore, the ambulance should not be used as the sacrificial barrier. A police or fire vehicle would be a better choice (if available.) Follow standard operating procedures for the situation, whether you are first on the scene or one of many responders. Call for help if necessary.



The standard operating procedures for scene protection are--



Four horizontal lines for writing notes, located in the bottom right section of the page.

Danger Zones

If the emergency is a fire, HAZMAT, or other such incident, park the ambulance far enough away to protect the crew and the patient. Don't park near damaged vehicles, because they might catch fire and explode. In the case of a vehicle wreck, park at least 50 feet away from the wreckage. This will protect the ambulance from broken glass and debris from the wreckage. Also be aware of any fuel leaking from wrecked vehicles. The scene commander should direct you to a location. In addition, avoid parking the ambulance where it will be an obstacle to other emergency personnel.

If you must park on a hill, exercise special care. Be sure to set the ambulance's parking brake. Remember that stretchers can roll. Your organization must use wheel chucks as a further safety feature. In addition, position the front wheels so that if the vehicle starts to roll the wheels will hit the curb.

Traffic Flow

The ambulance should be parked so that it does not block traffic. If an ambulance is parked in such a way that it's causing traffic problems, then at least one side of the vehicle is unsafe for access by the crew.

However, there may be times when you must place the vehicle amidst traffic flow. When responding to an emergency in a business district, you may need to double-park or otherwise inconvenience motorists. Your first priority should be patient care.

Ease of Departure

Park the vehicle in a position which provides for an easy departure and in the direction of the medical facility. Avoid having to back into traffic or steer around obstacles once the patient has been loaded.

When responding to a home, it may be better to park in the street rather than a driveway. This is especially true if the house is near the street, or if the driveway is steep or narrow. Parking on the street will prevent having to back into or out of a driveway. This can be difficult and dangerous on residential streets due to the presence of children, pets, and obstacles like bushes and parked cars.

Distance from Patient

Unfortunately, the need to be near to the patient frequently overrides the first three issues--safety, traffic flow, and ease of departure.

The patient care equipment is stored in the ambulance, and the patient will most likely be transported in the ambulance. Therefore, the back doors of the ambulance should be placed close to the patient. However, don't park so close that fumes from the engine overcome the crew or the patient.

The key to protecting the vehicle and crew is to think ahead about the consequences of your actions. Before parking the ambulance, remember to consider each of these factors--

- safety
 - traffic flow
 - ease of departure
 - distance from patient.
-

For each of the following diagrams, we will discuss the advantages and disadvantages of the parking configuration. Break up into groups of two or three. Look at each diagram and discuss the advantages and disadvantages. Have someone write down your answers. When you are finished, we will discuss your answers as a class.

Diagram 1

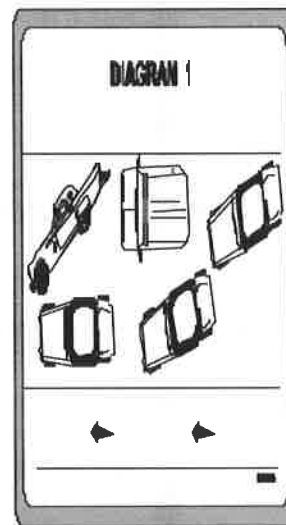

What are the possible advantages of this parking configuration?





What are the possible disadvantages of this parking configuration?



Diagram 2

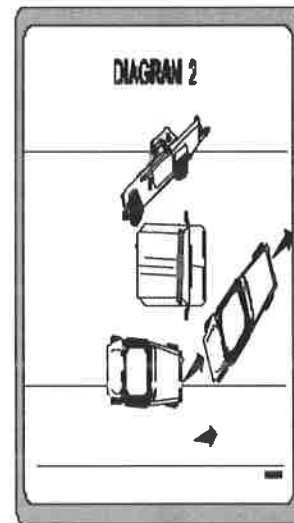

Traffic flow



What are the possible advantages of this parking configuration?





What are the possible disadvantages of this parking configuration?



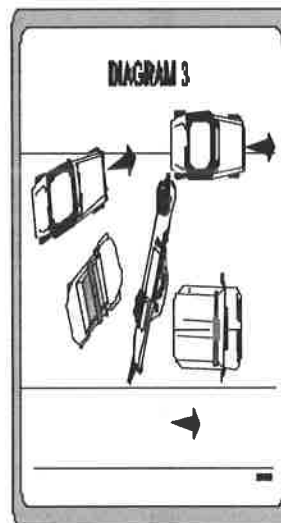

Diagram 3





What are the possible advantages of this parking configuration?

	<hr/> <hr/> <hr/> <hr/>
	<p>What are the possible disadvantages of this parking configuration?</p>
	<hr/> <hr/> <hr/> <hr/>
	<p>Diagram 4</p>





	<p>What are the possible advantages of this parking configuration?</p>
	<hr/> <hr/> <hr/> <hr/>
	<p>What are the possible disadvantages of this parking configuration?</p>
	<hr/> <hr/> <hr/> <hr/>

Diagram 5



What is wrong with this picture?

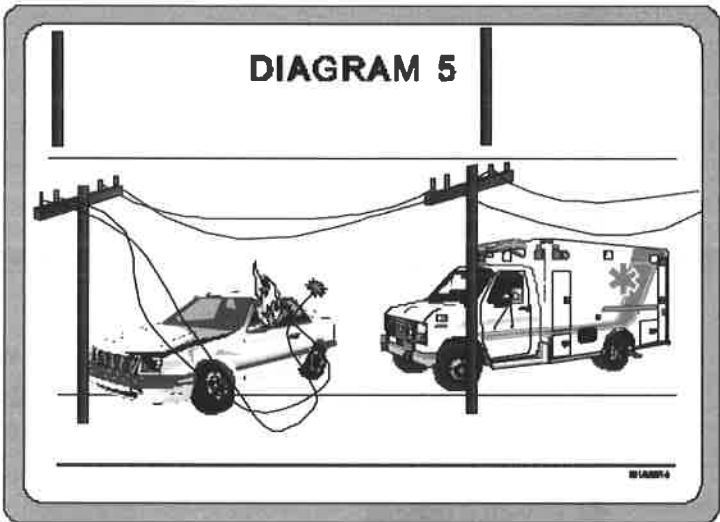

Warning Devices

A number of warning devices are available to help protect the ambulance at the scene. Warning devices should be placed to define the accident scene and mark temporary traffic lanes.



The standard operating procedures for using warning devices are--



There are several choices of warning devices which serve various purposes for protecting the scene. Flares and warning triangles are generally placed on the ground, whereas cyalumes (hand-held chemical light sticks), flashlights, and vests are held or worn by someone to warn others of the potential danger.

Flares

A flare is a stick made of combustible material which burns brightly for a certain length of time. A flare may not burn long enough for the situation. If the flare is not long enough for the incident, lay a flare on the ground and place the head of a second flare, with the cap removed, on the base of the first flare. The first flare will ignite the second flare. Don't put flares where they'll be extinguished or washed away by washdown hoses.

Be very careful when igniting a flare. They burn at very high temperatures and drip when burning. Follow the manufacturer's instructions for igniting the flare. Never light the flare inside a vehicle. Don't use flares if combustible liquids or vapors are present. Don't place flares near dry vegetation.



What are the precautions for using flares?



When an emergency scene is limited to one side of the roadway, one flare should be placed alongside the scene; a second flare should be placed about 150 to 200 feet towards approaching traffic; the third flare should be

placed about 300 feet from the scene. If the emergency scene is on a two-lane road, you may want to place an additional flare 100-150 feet in front of the scene to warn oncoming traffic of the danger. In some cases you may find it necessary to place more flares in order to protect the scene.



What are some situations which may require the use of more warning devices?



An easy and efficient way to estimate the distance for flare placement is to count your steps as you walk quickly. The average pace is slightly more than two feet. For example, 50 paces is approximately 100 feet.

Warning Triangles

The large reflective orange-red triangles are effective warning devices and are much safer than flares. They are especially useful when combustible materials are present or when you are unsure of the dangers present. In addition, you do not need to be concerned about the length of time you will be using them.

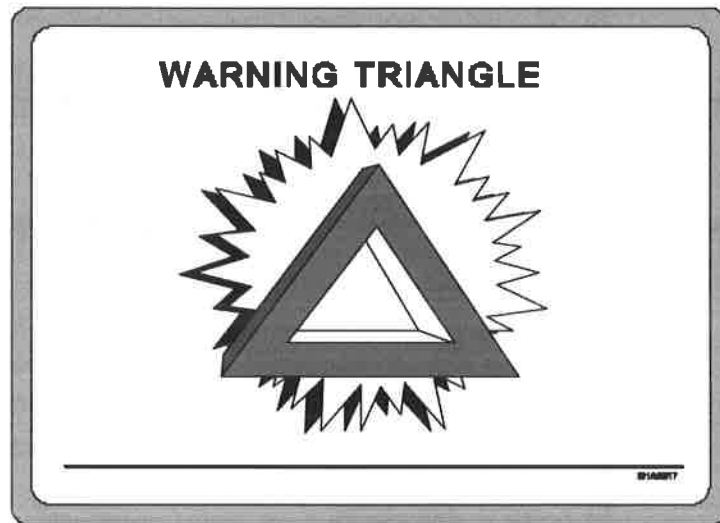

Warning triangles can be placed in the same configuration as flares.

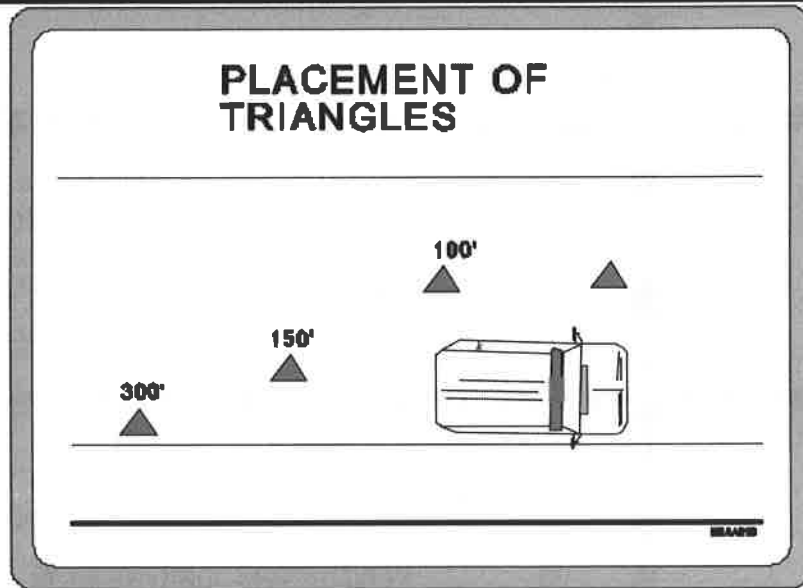

Flashlights/Cyalumes

Flashlights/cyalumes can be used to warn people of a potential danger, but they should not be relied upon. These tools depend on someone holding and waving them to be effective; therefore, they tie up a precious resource, emergency care providers. These devices may be given to a bystander with instructions on how they should be used. Anyone using these to warn traffic should also be given a safety vest increase visibility and safety.

Safety Vests

Safety vests are made of reflective material and are worn by someone who wants to be more visible. They are often used by someone who is working in a potentially dangerous area, near the flow of traffic.



What are the types of warning devices available to you?



AMBULANCE FIRES

In the event of a fire in the ambulance or the potential for fire due to a crash involving the ambulance, you are responsible for ensuring the safety of the passengers and crew. If a fire in the ambulance is detected, you should safely pull off the road and order the evacuation of the vehicle. (Refer to Lesson 8 for safe procedures for pulling off of the road.) Be sure to take necessary equipment for patient care and protection from the weather.

If the ambulance is involved in a crash, reduce the possibility for fire by shutting of the engine, any unnecessary electrical power, and oxygen/air tanks.

The ambulance should have at least two fire extinguishers aboard, one in the operator compartment and one in the patient compartment. If trained, you may want to attempt to extinguish a fire in the ambulance. Fire fighting should be left to trained individuals. Call for help if necessary.

**POINTS TO
REMEMBER**

Passenger safety is your responsibility.

Ensure the safety of the patient's family if they go to the medical facility.





Once at the scene, ensure that it is safe for the vehicle and crew to enter the area.

Park the ambulance so it does not cause a risk for the crew or vehicle.

Ensure the safety of all passengers and crew if there is an ambulance fire.

COURSE:	EMERGENCY VEHICLE OPERATOR COURSE (AMBULANCE): NATIONAL STANDARD CURRICULUM
MODULE A:	Ambulance Operations: The Basics
LESSON 10:	The Run
COURSE GOAL:	To provide ambulance operators with the knowledge and skills to operate their vehicles so that their vehicle, equipment, crew, and patients will be delivered safely and efficiently and the safety of the public will be assured during all phases of the delivery of the Emergency Medical Services (EMS) involving the ambulance
MODULE GOAL:	To provide ambulance operators with the knowledge required to safely and efficiently operate an ambulance in both non-emergency and emergency modes
LESSON GOAL:	To provide participants with knowledge on how to plan and carry out a successful run
PERFORMANCE OBJECTIVE(S):	<ul style="list-style-type: none"> Σ Identify prerun activities Σ Identify operational activities Σ Identify postrun activities
PM APPENDIX:	

**PARTICIPANT
MATERIALS:**

ICON LEGEND			
			
Notes	Response	Appendix	Local Requirements

INTRODUCTION

A lot of information has been covered in this course so far. You have learned about--

- legal issues affecting ambulance operations
- the basics of communications
- vehicle types and dynamics
- making sure your vehicle is ready for a run
- making sure you and the crew are ready for a run
- driving techniques for normal situations
- recognizing and driving in high-risk situations
- safety considerations during the run.

Now it's time to put it all together as it would happen. A run has three phases--prerun, operations, and postrun.

The prerun phase typically consists of--

- ensuring that you and the crew are ready
- ensuring that your ambulance is ready
- knowing primary and alternate routes

The operations phase typically consist of--

- leaving for the scene
- driving to the scene
- emergency scene operations
- transporting the patient
- operations at the medical facility

During the postrun phase you get your ambulance resupplied, cleaned, and decontaminated, if needed, and ready to make the next run.

Consider the following scenario and questions. Responses to questions will be discussed as a group.

SCENARIO

You and several others are arriving at the station to begin your shift. While you are settling in, you find out one of the crew only had an hour of sleep because of a sick child.



What should you do?





Why should you be concerned with another crew member's state of mind?





The supervisor has handled the problem of the tired EMT by making him get some sleep and bringing someone as a replacement. You have made sure the crew is ready to go on a run. You check the bulletin board for any important information which may affect a run today. The shift supervisor provides a briefing on the current conditions in your area which may affect operations on your shift. There is construction on Main Street with one lane blocked; there is a baseball game at the stadium; and there is a possibility of thunderstorms in the afternoon.



How will such conditions affect operations during a shift?



After the briefing, the supervisor tells you to check the ambulances. Ambulance A is still on a run, so you do a quick check or full check of ambulance B at the station. Ambulance A returns from the run, but it is a mess.



What should you do to prepare ambulance A for another run?



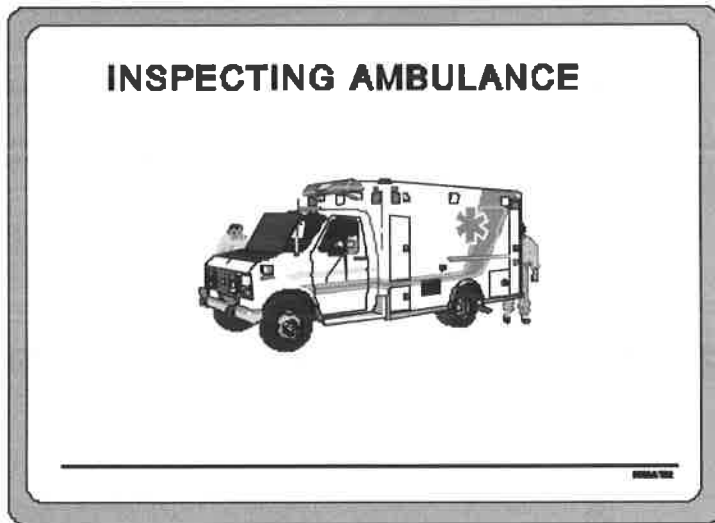

You inspect the ambulance while another crew member checks the patient compartment. You notice that the brake lights on the back of the

ambulance are not working.



What should you do?



Ambulance A has been repaired and returned to you. You inspect it again and it passes with flying colors. You report to your supervisor that you and your ambulance are ready to go when needed.

A true emergency call comes in from dispatch. You are to respond to an injury on one of the town's busiest roads. Dispatch gives you the location.

You and the crew get ready to leave.



What should you do before you move the ambulance?



You have left the station in an emergency response mode and are on your way to the scene, using your predetermined primary route. You are driving as smoothly as possible, while obeying all traffic laws.



Dispatch tells you there's flooding on one of the roads on your planned route. What do you do?



You have successfully navigated around the flooding but now have to clear a major controlled intersection before reaching the scene.

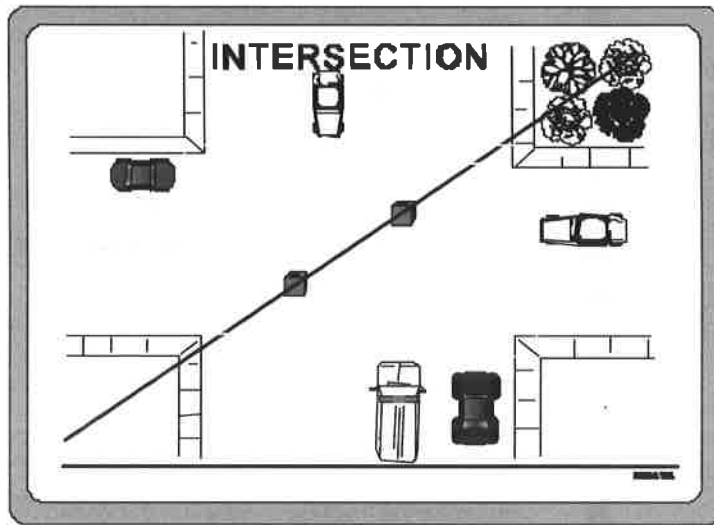

How would you clear this controlled intersection?



Four horizontal lines for writing an answer to the question above.

**CLEARING CONTROLLED
INTERSECTION (1 OF 2)**

- Siren to wail 300 feet before**
- Yelp 150 feet before**
- Remove foot from accelerator**
- Start braking**
- Two blasts airhorn**

SEARCH

**CLEARING CONTROLLED
INTERSECTION (2 OF 2)**

- Look left, front, right, and left**
- Make eye contact all drivers**
- When all clear, proceed under
10 mph**
- Continue yelp through
intersection**

SEARCH

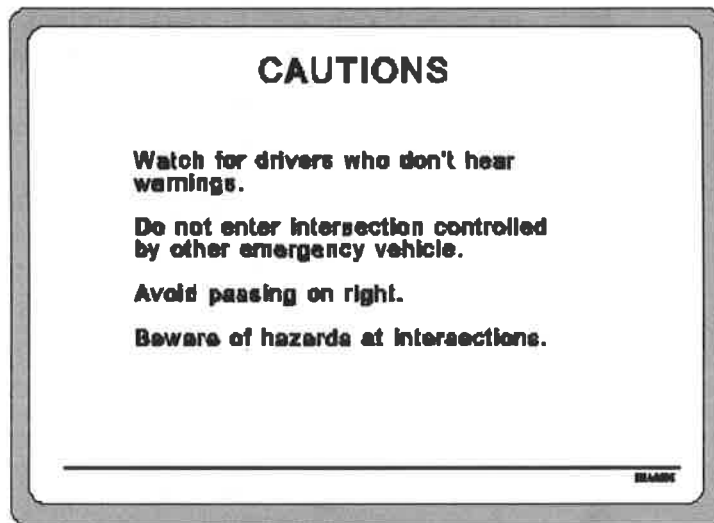

You have successfully cleared the intersection with no problems. You are traveling on a two-lane road at about 40 mph. You are going north. The opposing lane is clear. There are buildings and a sidewalk along the right side of the road. Suddenly a car backs out of a hidden driveway into your path, 50 yards in front of you. The driver can't see you because of the building. (If you drive in a rural area, change the scenario to a deer that runs into your path, 50 yards in front of you.)

STRAIGHT LINE BRAKING

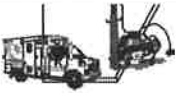
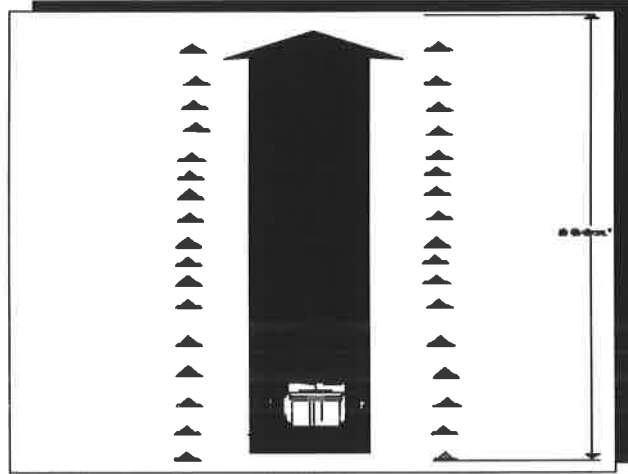

How would you avoid a crash?



That was close. But you made it without any problems. You are now approaching the scene of the emergency.



What would you do if there are already other emergency vehicles and personnel on the scene?





What if you are the first to arrive at the scene? What should you be looking for to protect the ambulance and crew?





What should you do if you detect downed power lines?

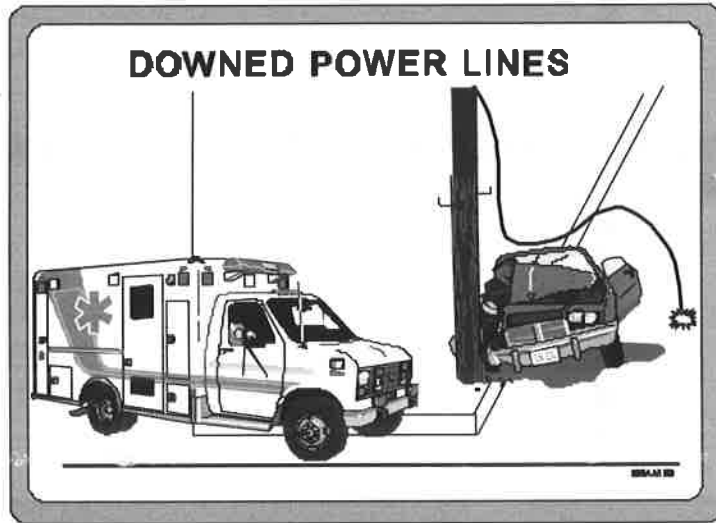



What should you do if you find a large crowd?

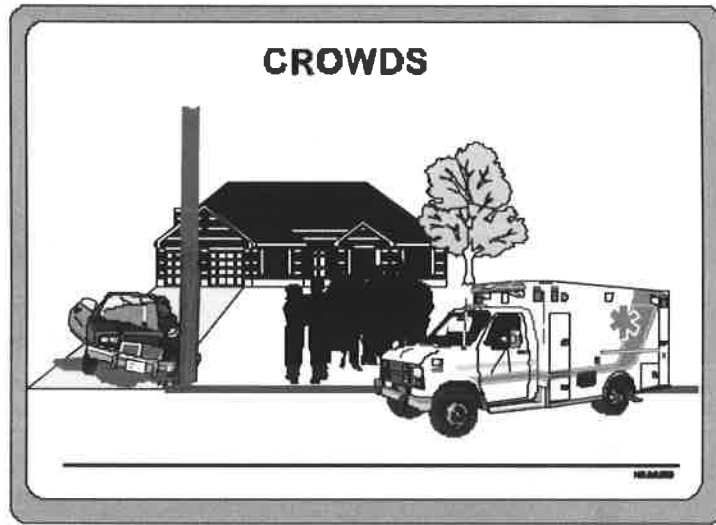

Four horizontal lines provided for writing a response to the question.



You are going to park now. What should you consider before parking the ambulance?

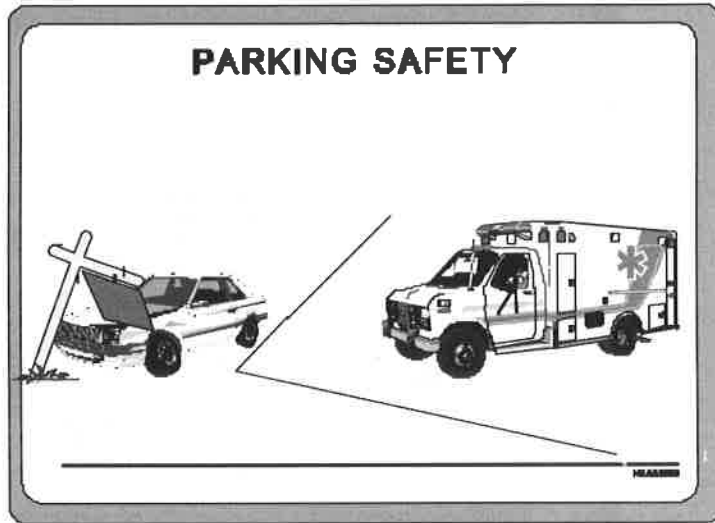



You have chosen the best possible place to park your ambulance. What should you do now, before assisting with patient care, to ensure that the ambulance will remain operational?



The crew is preparing to transport the patient. The patient has been loaded into the ambulance.



What steps should you take before moving the ambulance?



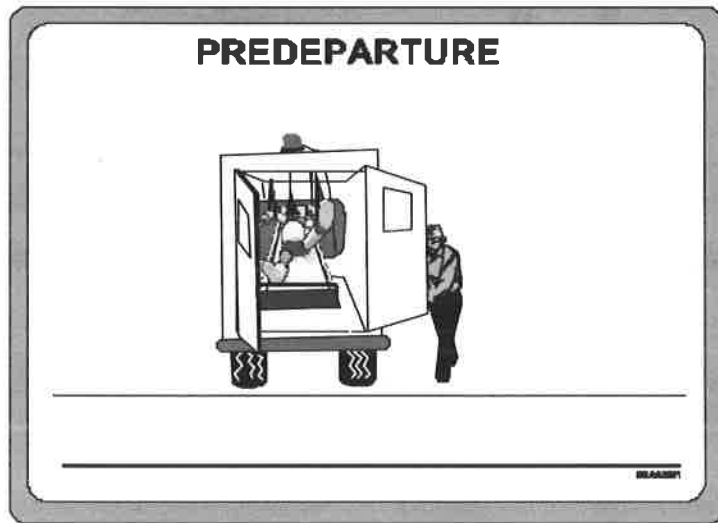

You are on your way to the medical facility.



What should you remember about transporting the patient?



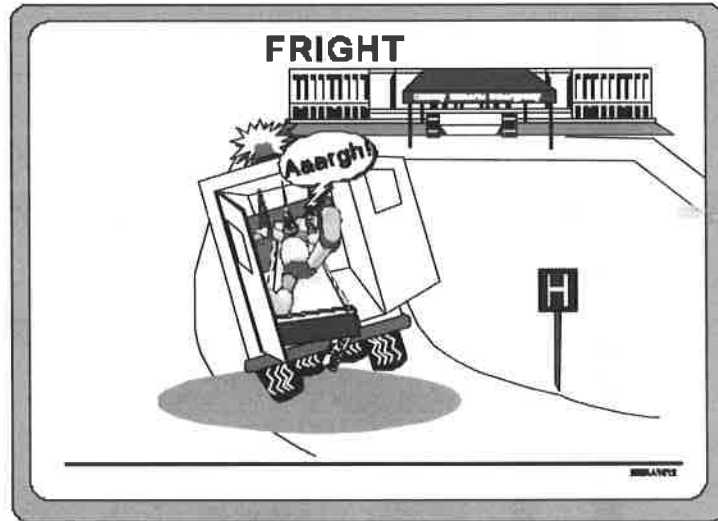

You are about to travel over a very bumpy section of road.



What should you do?

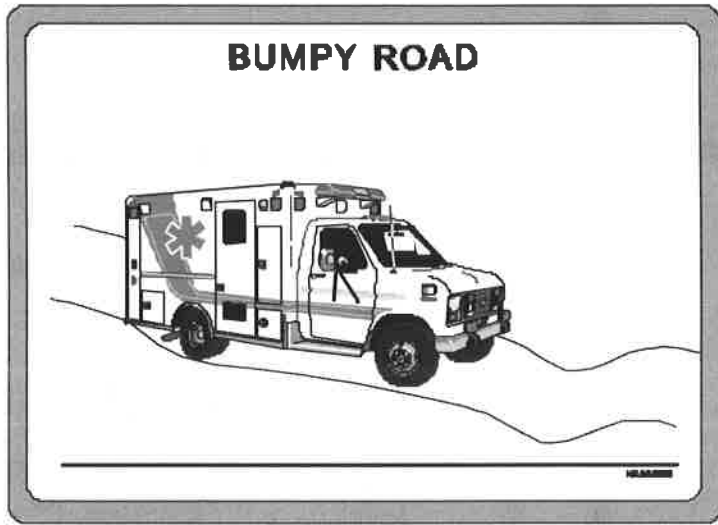

You have arrived at the medical facility and have parked the ambulance near the doors of the building for patient unloading.



What should you do?



The patient has been released into the care of the medical facility.

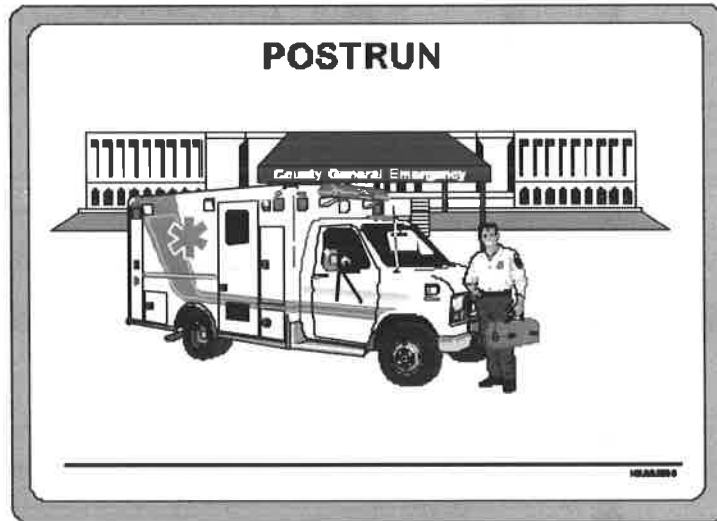

What should you do to get the ambulance ready for the next run?



Four horizontal lines provided for writing an answer to the question.

**POINTS TO
REMEMBER**

The three phases of a run are--

1. prerun
2. operational activities
3. postrun

Prerun consists of ensuring operator readiness, ensuring vehicle readiness, and route familiarization.

Operations consists of departing for the scene, driving to the scene, emergency scene operations, transporting the patient, and operations at the medical facility.

Postrun consists of any activities you did not perform in any other phase which prepares you or the ambulance for the next run.

The next step in the course is observation and practice of the skills needed to operate the ambulance safely and efficiently.

The final step in the course is evaluation of your performance on the job.

MODULE B

AMBULANCE OPERATION: DEMONSTRATION AND PRACTICE

MODULE GOAL

The goal of this module is to provide ambulance operators with the skills to safely and efficiently operate an ambulance.

MODULE OVERVIEW

It is important that you be able to identify those situations that result in a high number of ambulance crashes. Crash prevention requires that the operator learn the appropriate procedures and develop low-risk habits.

Ambulance operators often are involved in crashes at intersections, when backing, parking at the medical facility, turning around, and changing lanes. The exercises in Module B are designed for you to learn how to perform each of these maneuvers safely.

You will learn to inspect and operate an ambulance on a driving range prior to operating in a job environment. Module C describes the on-the-job training where all the skills and knowledge from Modules A and B will be used to perform the job.

MODULE EXERCISES

There are ten exercises in this module. The order in which these exercises are conducted may be modified.

	<u>Page</u>
The Serpentine	6
Diminishing Clearance	11
Braking While Turning	15
Straight Line Braking	19
U-Turn	23
Three-Point Turn	27
Right Side Road Turn	31
Left Side Road Turn	35
Slow Speed Lane Change	39
Perpendicular Parking, Back In and Drive Out	43

HOW TO CONDUCT EXERCISES

The exercises are conducted using the concept of performance-oriented training. This concept is very simple and is success oriented. The following steps implement this concept. Each instructor will explain, demonstrate, coach, and let you practice before you are evaluated. For some exercises, there may be additional participants in the ambulance playing the role of the patient on the stretcher and/or the Emergency Medical Technician in the patient compartment.

The instructor will follow these procedures for each exercise:

1. Explain to you what is to be accomplished and the acceptable performance standard.

Σ Be sure you understand what is expected.

Σ Use the exercise sheet to follow along with the instructor's explanation.

2. Demonstrate the procedure to you.

Σ Watch and listen to the instructor's demonstration.

Σ You will integrate several different actions.

Σ Ask questions about any part of the exercise.

3. Coach you while you practice the task.

Σ Start each exercise slowly.

Σ Stop if you don't understand something.

Σ Ask questions about any part of the exercise.

4. Let you practice the task until you can meet the standard.

Σ Practice the correct procedure.

Σ Practice until you have met the performance standard.

Σ Tell the instructor when you are ready to be evaluated.

Instructions to Participants

Σ Ask questions about any part of the exercise.

5. Evaluate your performance of each task.

Σ You have practiced and know how to do the task properly.

Σ Do your best.

MODULE EXERCISE SHEETS

Each module exercise contains three sheets.

The first sheet shows a *diagram of the exercise* as it is laid out on the course. It shows the dimensions of the exercise and where the traffic cones will be placed. For the driving range, some of these cones may be changed somewhat, and these changes will be pointed out to you prior to conducting the exercise.

The second sheet provides *general exercise information*, such as the purpose of the exercise, how it is to be performed, and some of the things you and the instructor will be doing during the exercise.

The third sheet is an *evaluation rating form* the instructor uses when testing the performance of the exercise. Remember, you won't be evaluated until you have had a chance to practice and have told the instructor that you are ready.

The rows of boxes are a guide to the number of practices you may need to achieve the standard. However, you may achieve the standard on your first attempt. These sheets will become a part of your training record.

TRAINING AMBULANCES

The ambulances used during Module B should be those that you will operate when on the job. If this is not possible, similar models will be used and the differences pointed out to you. Each ambulance should be in safe working condition, but may have discrepancies and require servicing or repair to add realism to the training. Those used on the driving range must be fully equipped and mechanically sound with high quality tires and fully functional safety and communication equipment.

If more than one ambulance will be used on the course, communication must be established between the vehicles to prevent accidents.

THE COURSE

Any half-mile or greater stretch of straight, four-lane roadway that can be closed off, or abandoned airport runways, may be used. The dimensions of the exercises used in this module may be altered to provide the most training in the space available.

Your organization may have a permanent range that is used for emergency vehicle operator training. Permanent ranges may or may not provide enough space to set up all of the exercises. This may also be the case if a vacant field or parking lot is used to set up the course.

DRIVING SPEED

All driving exercises are designed for you to learn the control and handling of the ambulance, not its speed capabilities. Each exercise will be run slowly at first and the speed gradually increased as your proficiency improves. None of the exercises is designed to be run at highway speeds.

USE OF GROUND GUIDES

You should use ground guides when backing an ambulance and operating in a congested area such as a crash scene. However, during the initial backing exercises, you will learn to use the mirrors; the exercise should first be performed using the mirrors only. Once you can use the mirrors to back successfully while turning in both directions and to stop at a designated point, the ground guide should be added for all subsequent backing maneuvers. The hand signals discussed in lesson 3 will be demonstrated by the instructor. You and the ground guide will have a chance to practice them and using the mirror prior to practicing backing the ambulance with the ground guide.

RANGE RULES

There are several rules that must be followed at all times while on the driving range unless otherwise told to disregard for a particular exercise.

- No food or drinks in ambulances.
- No smoking in ambulances.
- No alcoholic beverages on the driving range.
- Seat belts shall be worn at all times.

- Do not exceed speed limits established locally at any time on the range.
- Unsafe vehicles will not be allowed on the range.
- Report all equipment malfunctions immediately.
- Ambulance operators must have a state automobile or higher driver's license before operating on the range.
- Follow directions of the instructors at all times.

These are sample rules. Each organization will have a list of local rules that will be appropriate for their course. The course rules will be discussed with you before going to the course.

EVALUATING YOUR PERFORMANCE

You either pass or fail the exercise based on your ability to perform the maneuver as outlined on the evaluation sheet. If you have difficulty with a certain aspect of the exercise, the instructor will decide if additional coaching, practice, or both will be necessary for you to achieve the standard. Each exercise will have a locally developed standard based on the actual exercise layout and type ambulance used. Time will not be a part of the standard. A sample standard : Without hitting a cone, move the ambulance forward so that the front bumper is within 12 inches.

CONCURRENT TRAINING

The training manager will decide how many participants go to the course. The size of the course, number of ambulances and instructors available for training, and other factors can limit the number of participants that can be accommodated in a training session. If participants will be idle, the training manager will consider establishing concurrent training stations. These stations could provide additional training on a variety of subjects such as vehicle inspections, communications, and emergency procedures. The concurrent training can be conducted by a participant or by an instructor.

SERPENTINE COURSE

Full stop

Begin braking

Begin to decelerate

Maintain steady speed

Accelerate smoothly

Begin from a standstill

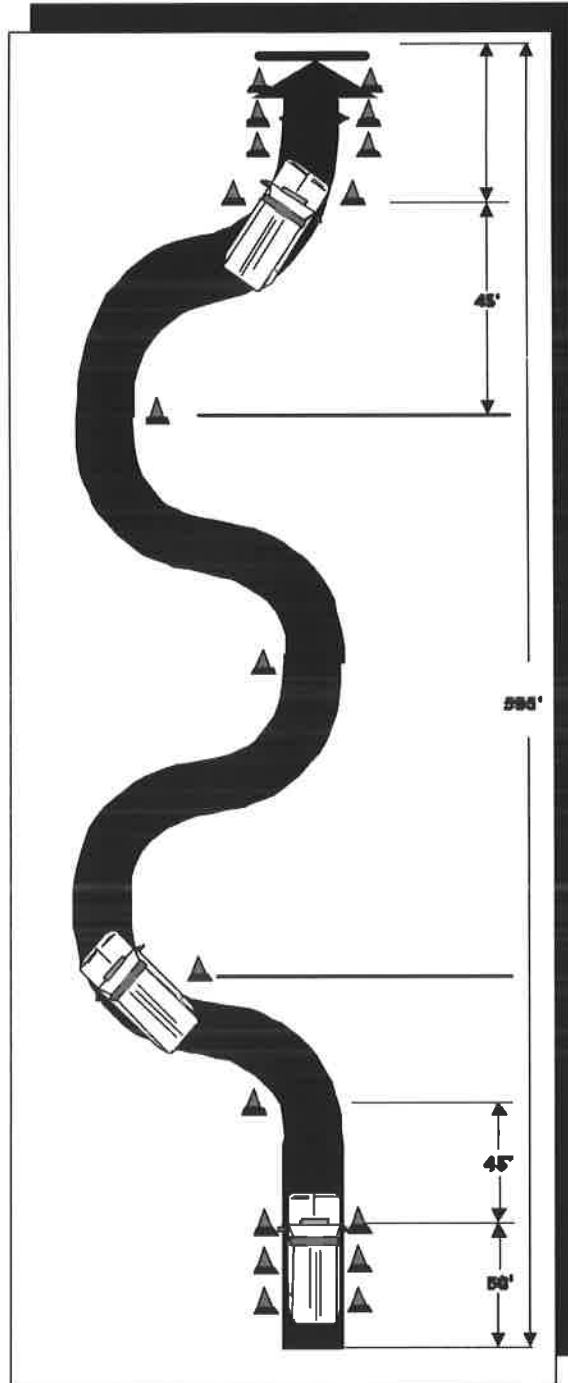

COURSE REQUIREMENTS

595' x 70'

Requires 20 traffic cones

Serpentine

Purpose:

To develop the basic skills of coordinating acceleration, timing of steering movements, and the use of the 9 - 3 hand position. It also develops the ability to judge the relationship of fixed objects to the vehicle.

This exercise does not simulate a real world situation. It develops the skills for use in other exercises and gives you the opportunity to become familiar with how the vehicle handles and to build confidence. It will be taught before exercises using the 9 - 3 hand position.

Procedure:

Begin from a standstill and accelerate smoothly. Maintain steady speed on course. Begin braking at the assigned point and bring ambulance to a full stop at the stop line.

Instructor:

1. Explains purpose of exercise and key factors of the exercise.
2. Demonstrates exercise at moderate speed.
3. Demonstrates exercise at required speed.

Participant:

1. Assumes proper driving position; seat, mirrors, seat belt.
2. Accelerates smoothly.
3. Negotiates the course smoothly.
4. Keeps steering movements constant and even.
5. Maintains 9 - 3 hand position.
6. Maintains constant speed throughout the course once assigned speed is reached.
7. Passes closely to the cones.
8. Brakes smoothly to a full stop.

THIS PAGE INTENTIONALLY LEFT BLANK.

Serpentine Exercise Rating

Participant's name _____		Date _____	Vehicle make/number _____			
			<u>Practice Exercises</u>			
			1	2	3	4
A.	Accelerated smoothly.....	<input type="checkbox"/>	<input type="checkbox"/>	<input type="checkbox"/>	<input type="checkbox"/>	
B.	Maintained required speed.....	<input type="checkbox"/>	<input type="checkbox"/>	<input type="checkbox"/>	<input type="checkbox"/>	
C.	9-3 hand position.....		<input type="checkbox"/>	<input type="checkbox"/>	<input type="checkbox"/>	<input type="checkbox"/>
D.	Maintained constant speed.....	<input type="checkbox"/>	<input type="checkbox"/>	<input type="checkbox"/>	<input type="checkbox"/>	
E.	Steering control.....		<input type="checkbox"/>	<input type="checkbox"/>	<input type="checkbox"/>	<input type="checkbox"/>
F.	Accelerator, steering coordination....	<input type="checkbox"/>	<input type="checkbox"/>	<input type="checkbox"/>	<input type="checkbox"/>	
G.	Foot movement.....		<input type="checkbox"/>	<input type="checkbox"/>	<input type="checkbox"/>	<input type="checkbox"/>
H.	Use of brakes.....		<input type="checkbox"/>	<input type="checkbox"/>	<input type="checkbox"/>	<input type="checkbox"/>

Number of cones hit _____

Reaction time was adequate. YES NO

Vehicle remained under control at all time. YES NO

Describe negative actions or attitudes.

Failed to complete exercise because _____

All requirements were met. YES NO

GENERAL REMARKS:

Instructor's signature _____ Date _____

I have seen the completed form and have been given an explanation of my performance and rating.

Participant's signature _____ Date _____

THIS PAGE INTENTIONALLY LEFT BLANK.

DIMINISHING CLEARANCE

Brake to a full stop

Begin braking

Course entry

Begin from a standstill

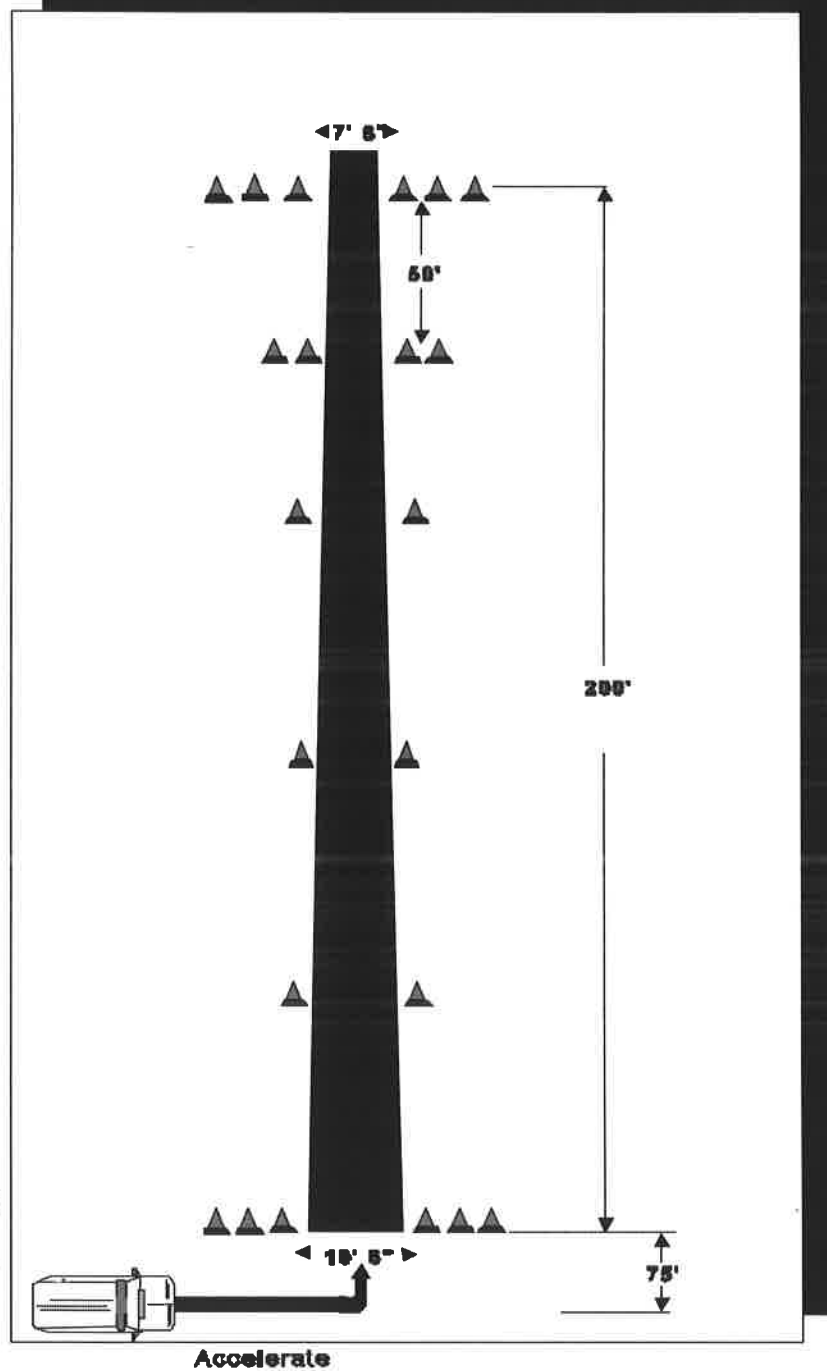

Diminishing Clearance

Purpose:

To give the operator the sensation of driving in a street that starts out at 10 ft. 6 inches and ends up at 7 ft. 6 inches. Judges the operator's ability to perceive change in dimension while driving forward and to use mirrors while backing.

Procedure:

Begin from a standstill facing perpendicular to the course. Accelerate and turn to enter the course. Maintain a steady speed while on the course. Keep the ambulance on the centerline of the course and begin braking at the assigned point to bring the ambulance to a full stop at the stop line. The distance over or behind the stop line will be recorded. Ambulance will then be backed full length of course and stopped at course entry points.

Instructor:

1. Explains purpose of exercise and key factors of the exercise.
2. Demonstrates exercise at slow speed.
3. Demonstrates exercise at required speed.

USE A GROUND GUIDE WHEN BACKING

Participant:

1. Assumes proper driving position; seat, mirrors, seat belt.
2. Accelerates smoothly.
3. Negotiates the course smoothly.
4. Keeps steering movements constant and even.
5. Maintains 9 - 3 hand position.
6. Maintains constant speed throughout the course.
7. Maintains ambulance on course centerline.
8. Brakes smoothly to a full stop.
9. Uses mirrors while backing.
10. Accelerates smoothly in reverse and maintains slow steady speed while in reverse.
11. Brakes smoothly to full stop at course entry point.

Diminishing Clearance Exercise Rating

Participant's name _____ Date _____ Vehicle make/number _____

		<u>Practice Exercises</u>			
		1	2	3	4
A.	Accelerated smoothly.....	<input type="checkbox"/>	<input type="checkbox"/>	<input type="checkbox"/>	<input type="checkbox"/>
B.	Maintained required speed.....	<input type="checkbox"/>	<input type="checkbox"/>	<input type="checkbox"/>	<input type="checkbox"/>
C.	9-3 hand position.....		<input type="checkbox"/>	<input type="checkbox"/>	<input type="checkbox"/>
D.	Maintained constant speed.....	<input type="checkbox"/>	<input type="checkbox"/>	<input type="checkbox"/>	<input type="checkbox"/>
E.	Steering control.....		<input type="checkbox"/>	<input type="checkbox"/>	<input type="checkbox"/>
F.	Accelerator, steering coordination....	<input type="checkbox"/>	<input type="checkbox"/>	<input type="checkbox"/>	<input type="checkbox"/>
G.	Maintained centerline position.....	<input type="checkbox"/>	<input type="checkbox"/>	<input type="checkbox"/>	<input type="checkbox"/>
H.	Foot movement.....		<input type="checkbox"/>	<input type="checkbox"/>	<input type="checkbox"/>
I.	Use of brakes.....		<input type="checkbox"/>	<input type="checkbox"/>	<input type="checkbox"/>
J.	Use of mirrors.....		<input type="checkbox"/>	<input type="checkbox"/>	<input type="checkbox"/>

Number of cones hit _____

Reaction time was adequate. YES NO

Vehicle remained under control at all time. YES NO

Distance OVER/BEHIND stop line _____ feet _____ inches

Describe negative actions or attitudes.

Failed to complete exercise because _____

All requirements were met. YES NO

GENERAL REMARKS:

Instructor's signature _____ Date _____

I have seen the completed form and have been given an explanation of my performance and rating.

Participant's signature _____ Date _____

THIS PAGE INTENTIONALLY LEFT BLANK.

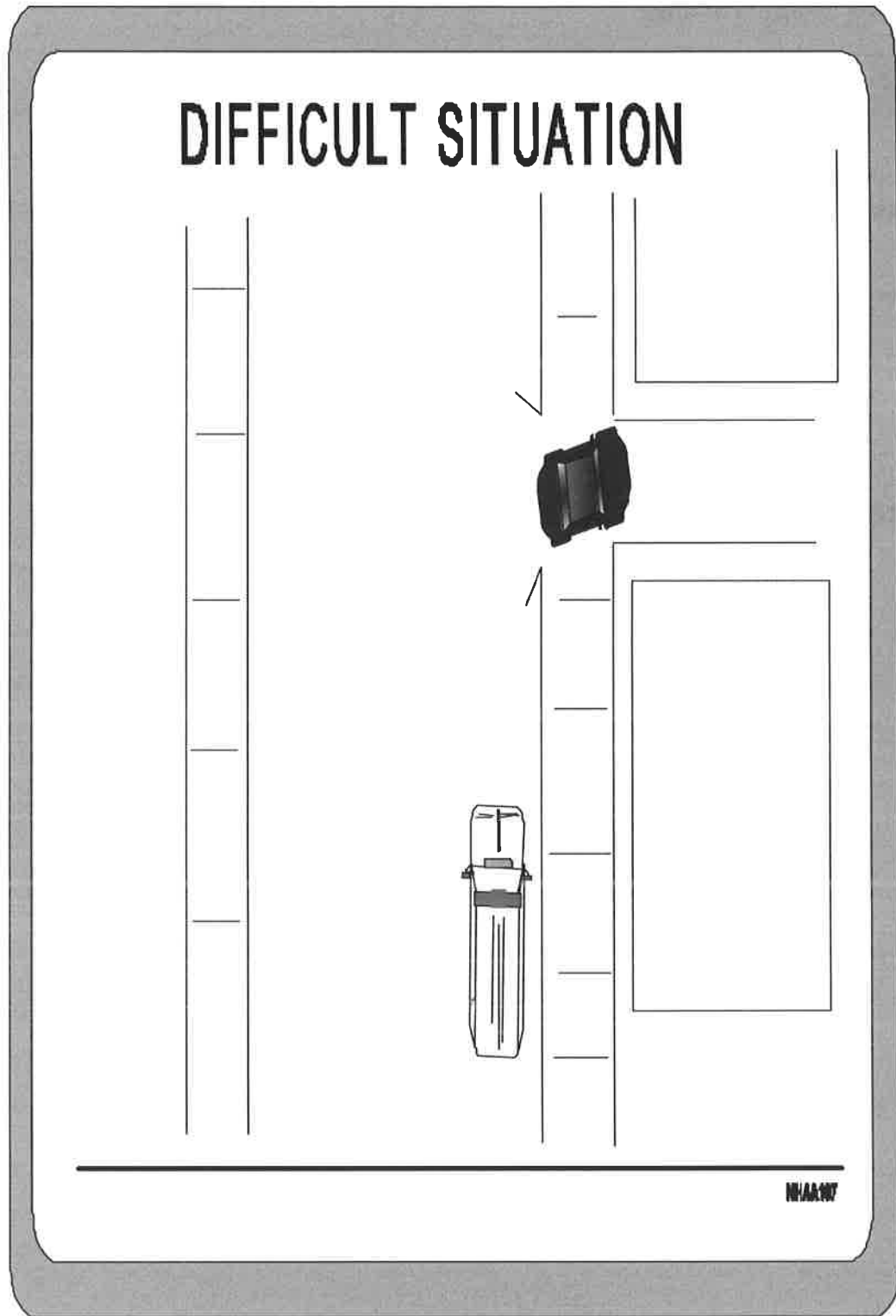

Braking While Turning

Purpose:

To develop skill in achieving and maintaining maximum braking pressure while controlling the direction of the vehicle.

Procedure:

Enter course at selected speed. At brake cue cones, begin maximum braking. Steer through course while braking. Do not lock brakes.

Instructor:

1. Explains purpose of exercise and key factors of the exercise.
2. Demonstrates exercise at moderate speed.
3. Demonstrates exercise at required speed.

Participant:

1. Assumes proper driving position; seat, mirrors, seat belt.
2. Enters course at speed determined by instructor.
3. Negotiates the course smoothly.
4. Maintains 9 - 3 hand position.
5. Exits the course at the direction of the instructor.

Braking While Turning Exercise Rating

Participant's name _____		Date _____	Vehicle make/number _____				
		<u>Practice Exercises</u>					
		1 2 3 4					
A.	Entered course correctly.....	<input type="checkbox"/>	<input type="checkbox"/>	<input type="checkbox"/>	<input type="checkbox"/>		
B.	Maintained required speed.....	<input type="checkbox"/>	<input type="checkbox"/>	<input type="checkbox"/>	<input type="checkbox"/>		
C.	9 - 3 hand position.....			<input type="checkbox"/>	<input type="checkbox"/>	<input type="checkbox"/>	<input type="checkbox"/>
D.	Controlled acceleration.....	<input type="checkbox"/>	<input type="checkbox"/>	<input type="checkbox"/>	<input type="checkbox"/>		
E.	Steering control.....			<input type="checkbox"/>	<input type="checkbox"/>	<input type="checkbox"/>	<input type="checkbox"/>
F.	Accelerator, steering coordination....	<input type="checkbox"/>	<input type="checkbox"/>	<input type="checkbox"/>	<input type="checkbox"/>		
G.	Smooth acceleration.....			<input type="checkbox"/>	<input type="checkbox"/>	<input type="checkbox"/>	<input type="checkbox"/>
H.	Foot movement.....			<input type="checkbox"/>	<input type="checkbox"/>	<input type="checkbox"/>	<input type="checkbox"/>
I.	Use of brakes.....			<input type="checkbox"/>	<input type="checkbox"/>	<input type="checkbox"/>	<input type="checkbox"/>

Number of cones hit _____

Reaction time was adequate. YES NO

Vehicle remained under control at all time. YES NO

Describe negative actions or attitudes.

Failed to complete exercise because _____

All requirements were met. YES NO

GENERAL REMARKS:

Instructor's signature _____ Date _____

I have seen the completed form and have been given an explanation of my performance and rating.

Participant's signature _____ Date _____

THIS PAGE INTENTIONALLY LEFT BLANK.

STRAIGHT LINE BRAKING

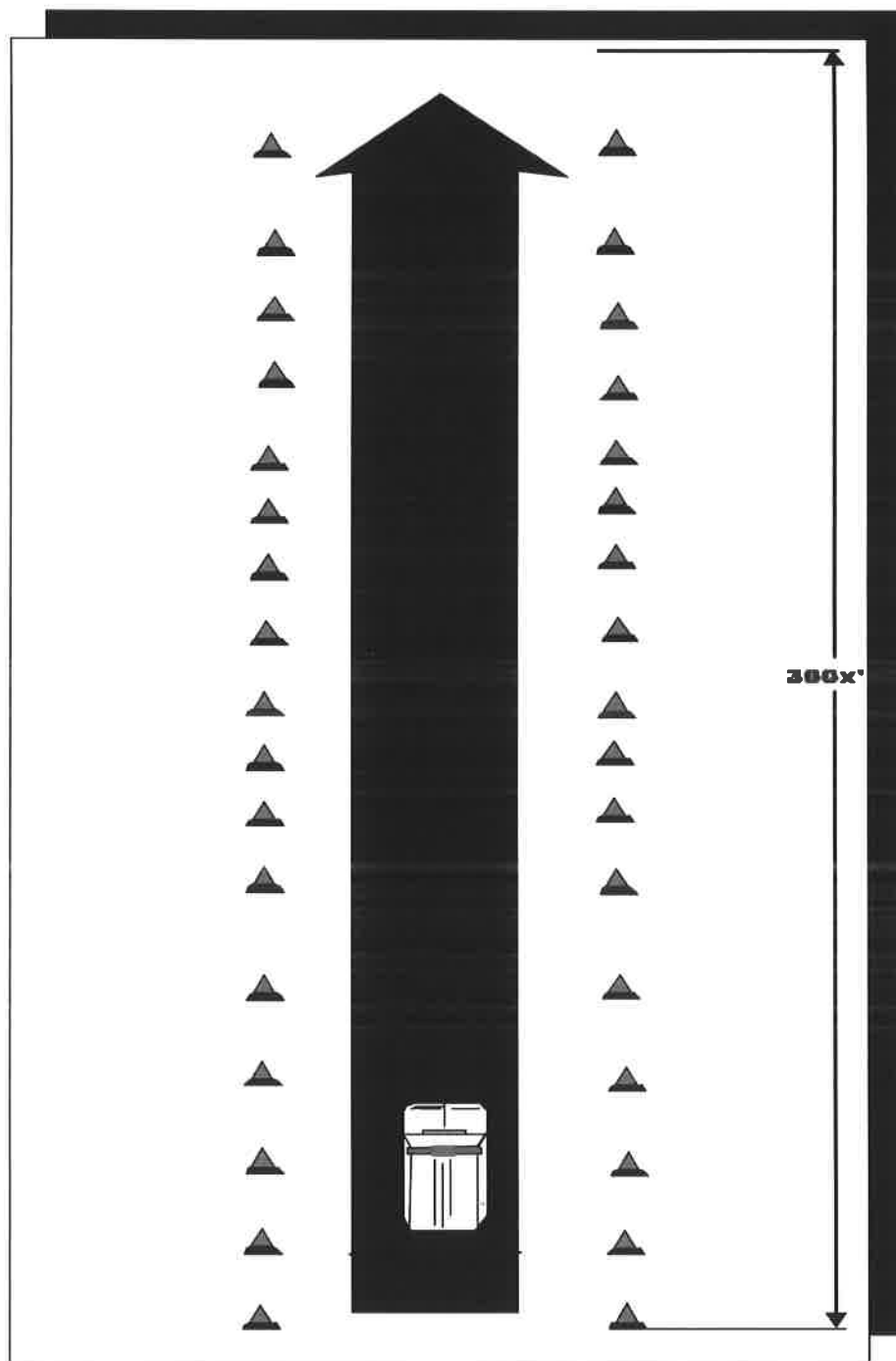

Straight Line Braking

Purpose:

To teach operator to brake quickly and smoothly on demand. Combines reaction time, smooth braking, and steering skills.

Procedure:

Enter course at selected speed. At instructor command, quickly bring ambulance to smooth, full stop. Maintain straight direction and stop without locking brakes.

Instructor:

1. Explains purpose of exercise and key factors of the exercise.
2. Demonstrates exercise at moderate speed.
3. Demonstrates exercise at required speed.

Participant:

1. Assumes proper driving position; seat, mirrors, seat belt.
2. Enters course at speed determined by instructor.
3. Negotiates the course smoothly.
4. Keeps steering movements constant and even.
5. Maintains 9 - 3 hand position.
6. Maintains constant speed throughout the course.
7. Passes closely to the cones.
8. Brakes smoothly on instructor command without locking brakes.

Straight Line Braking Exercise Rating

Participant's name _____ Date _____ Vehicle make/number _____

		<u>Practice Exercises</u>			
		1	2	3	4
A.	Entered course correctly.....	<input type="checkbox"/>	<input type="checkbox"/>	<input type="checkbox"/>	<input type="checkbox"/>
B.	Maintained required speed.....	<input type="checkbox"/>	<input type="checkbox"/>	<input type="checkbox"/>	<input type="checkbox"/>
C.	9 - 3 hand position.....		<input type="checkbox"/>	<input type="checkbox"/>	<input type="checkbox"/>
D.	Controlled acceleration.....	<input type="checkbox"/>	<input type="checkbox"/>	<input type="checkbox"/>	<input type="checkbox"/>
E.	Steering control.....		<input type="checkbox"/>	<input type="checkbox"/>	<input type="checkbox"/>
F.	Accelerator, steering coordination....	<input type="checkbox"/>	<input type="checkbox"/>	<input type="checkbox"/>	<input type="checkbox"/>
G.	Smooth acceleration.....		<input type="checkbox"/>	<input type="checkbox"/>	<input type="checkbox"/>
H.	Foot movement.....		<input type="checkbox"/>	<input type="checkbox"/>	<input type="checkbox"/>
I.	Use of brakes.....		<input type="checkbox"/>	<input type="checkbox"/>	<input type="checkbox"/>

Number of cones hit _____

Reaction time was adequate. YES NO

Vehicle remained under control at all time. YES NO

Describe negative actions or attitudes.

Failed to complete exercise because _____

All requirements were met. YES NO

GENERAL REMARKS:

Instructor's signature _____ Date _____

I have seen the completed form and have been given an explanation of my performance and rating.

Participant's signature _____ Date _____

THIS PAGE INTENTIONALLY LEFT BLANK.

UTURN

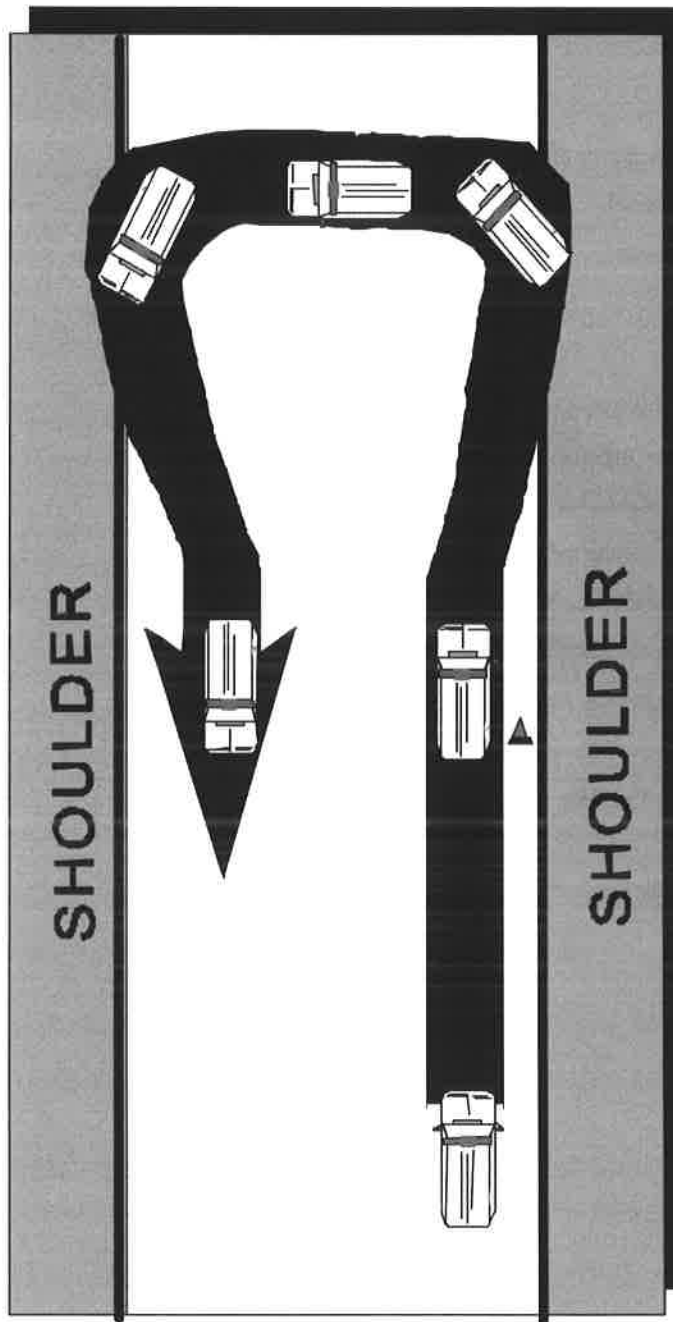

COURSE REQUIREMENTS

Use tape or paint to simulate two lane roadway

For longer ambulances, add width to shoulder

U-Turn

Purpose:

To develop the coordination of acceleration, turning, judgment of road width, and signaling.

Procedure:

Enter course and begin braking. Signal, check mirrors, and begin turn. Use shoulder areas to complete turn in one motion.

Instructor:

1. Explains purpose of exercise and key factors of the exercise.
2. Demonstrates exercise at moderate speed.
3. Demonstrates exercise at required speed.

Participant:

1. Assumes proper driving position; seat, mirrors, seat belt.
2. Enters course at speed determined by instructor.
3. Signals for a right turn at least 100 feet in advance.
4. Pauses momentarily to check for oncoming traffic.
5. Follows through with the counter clockwise turn.
6. Avoids situations with considerable cross traffic or pedestrians.
7. Crosses minimum number of traffic lanes (considerably safer).
8. Negotiates the course smoothly.
9. Keeps steering movements constant and even.
10. Maintains 9 - 3 hand position.
11. Exits the course at the direction of the instructor.

U-Turn Exercise Rating

Participant's name _____		Date _____	Vehicle make/number _____			
			<u>Practice Exercises</u>			
			1	2	3	4
A.	Entered course correctly.....	<input type="checkbox"/>	<input type="checkbox"/>	<input type="checkbox"/>	<input type="checkbox"/>	<input type="checkbox"/>
B.	Maintained required speed.....	<input type="checkbox"/>	<input type="checkbox"/>	<input type="checkbox"/>	<input type="checkbox"/>	<input type="checkbox"/>
C.	9 - 3 hand position.....		<input type="checkbox"/>	<input type="checkbox"/>	<input type="checkbox"/>	<input type="checkbox"/>
D.	Controlled acceleration.....	<input type="checkbox"/>	<input type="checkbox"/>	<input type="checkbox"/>	<input type="checkbox"/>	<input type="checkbox"/>
E.	Steering control.....		<input type="checkbox"/>	<input type="checkbox"/>	<input type="checkbox"/>	<input type="checkbox"/>
F.	Accelerator, steering coordination....	<input type="checkbox"/>	<input type="checkbox"/>	<input type="checkbox"/>	<input type="checkbox"/>	<input type="checkbox"/>
G.	Smooth acceleration.....		<input type="checkbox"/>	<input type="checkbox"/>	<input type="checkbox"/>	<input type="checkbox"/>
H.	Foot movement.....		<input type="checkbox"/>	<input type="checkbox"/>	<input type="checkbox"/>	<input type="checkbox"/>
I.	Use of brakes.....		<input type="checkbox"/>	<input type="checkbox"/>	<input type="checkbox"/>	<input type="checkbox"/>
J.	Signaled intention.....		<input type="checkbox"/>	<input type="checkbox"/>	<input type="checkbox"/>	<input type="checkbox"/>
K.	Checked mirror.....		<input type="checkbox"/>	<input type="checkbox"/>	<input type="checkbox"/>	<input type="checkbox"/>
L.	Turned head.....		<input type="checkbox"/>	<input type="checkbox"/>	<input type="checkbox"/>	<input type="checkbox"/>

Number of cones hit _____

Reaction time was adequate. YES NO

Vehicle remained under control at all time. YES NO

Describe negative actions or attitudes.

Failed to complete exercise because _____

All requirements were met. YES NO

GENERAL REMARKS:

Instructor's signature _____ Date _____

I have seen the completed form and have been given an explanation of my performance and rating.

Participant's signature _____ Date _____

THIS PAGE INTENTIONALLY LEFT BLANK.

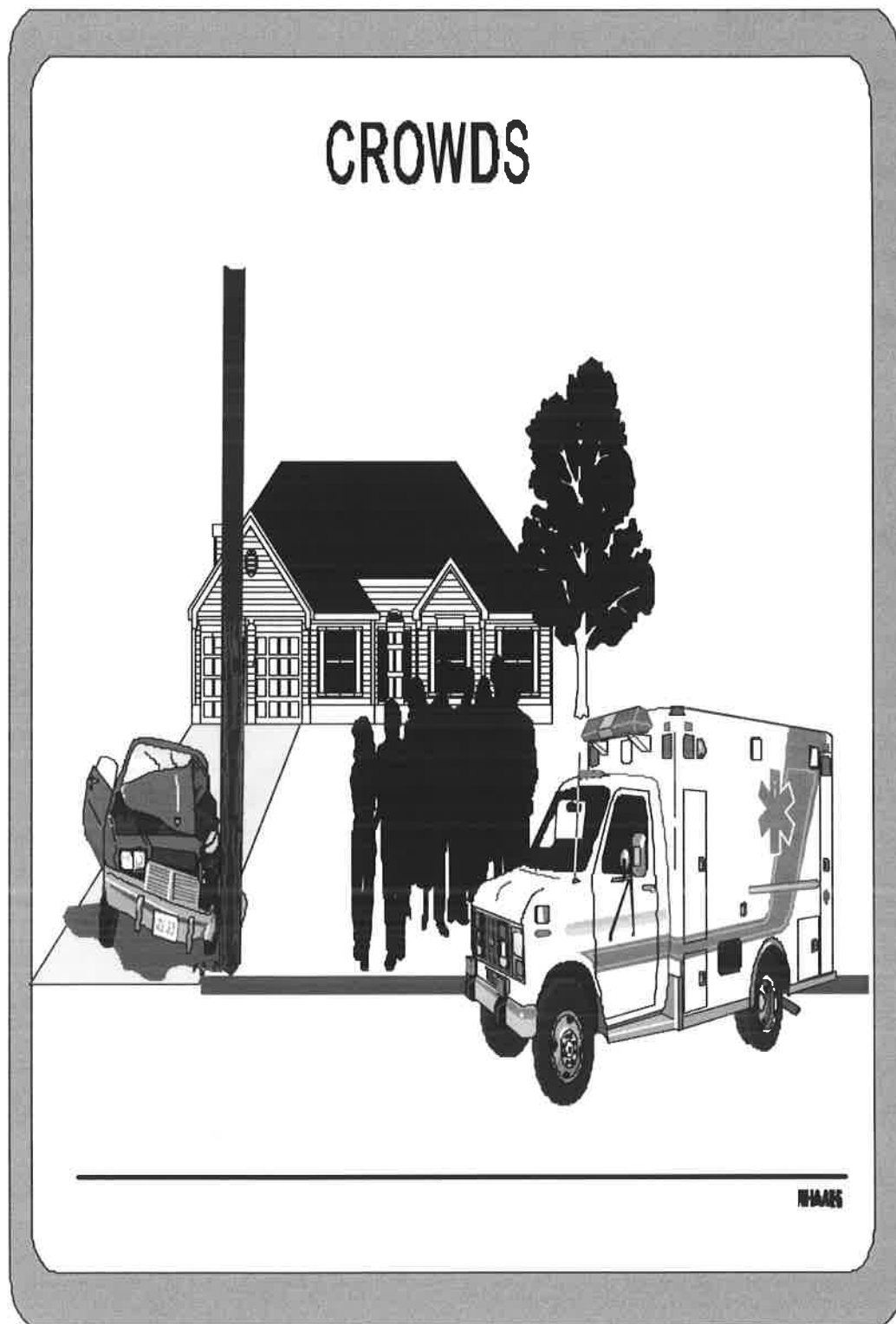

Three-Point Turn

Purpose:

To develop the coordination of acceleration, turning, judgment of road width, and signaling.

Procedure:

Check traffic. When clear, brake and turn to come to stop with front wheels on right shoulder. Begin backing and turning steering wheel to left. Stop when rear wheels are on left shoulder. Steer to the right and begin to accelerate. Move into right lane and continue forward.

Instructor:

1. Explains purpose of exercise and key factors of the exercise.
2. Demonstrates exercise at moderate speed.
3. Demonstrates exercise at required speed.

Participant:

1. Assumes proper driving position; seat, mirrors, seat belt.
2. Enters course at speed determined by instructor.
3. Checks rear traffic and signals for a stop at least 100 feet in advance.
4. Brings vehicle to a stop at approximately a 15-degree angle from the center of the road.
5. Begins backing turning the wheel slowly for the first 5 feet.
6. Steers counter clockwise until rear wheels barely hit the shoulder.
7. Moves forward into the right lane.
8. Negotiates the course smoothly.
9. Keeps steering movements constant and even.
10. Maintains 9 - 3 hand position.
11. Exits the course at the direction of the instructor.

Three-Point Turn Exercise Rating

Participant's name _____ Date _____ Vehicle make/number _____

		<u>Practice Exercises</u>			
		1	2	3	4
A.	Entered course correctly.....	<input type="checkbox"/>	<input type="checkbox"/>	<input type="checkbox"/>	<input type="checkbox"/>
B.	Maintained required speed.....	<input type="checkbox"/>	<input type="checkbox"/>	<input type="checkbox"/>	<input type="checkbox"/>
C.	9 - 3 hand position (going forward).	<input type="checkbox"/>	<input type="checkbox"/>	<input type="checkbox"/>	<input type="checkbox"/>
D.	Controlled acceleration.....	<input type="checkbox"/>	<input type="checkbox"/>	<input type="checkbox"/>	<input type="checkbox"/>
E.	Steering control.....		<input type="checkbox"/>	<input type="checkbox"/>	<input type="checkbox"/>
F.	Accelerator, steering coordination....	<input type="checkbox"/>	<input type="checkbox"/>	<input type="checkbox"/>	<input type="checkbox"/>
G.	Smooth acceleration.....		<input type="checkbox"/>	<input type="checkbox"/>	<input type="checkbox"/>
H.	Foot movement.....		<input type="checkbox"/>	<input type="checkbox"/>	<input type="checkbox"/>
I.	Use of brakes.....		<input type="checkbox"/>	<input type="checkbox"/>	<input type="checkbox"/>
J.	Signaled intention.....		<input type="checkbox"/>	<input type="checkbox"/>	<input type="checkbox"/>
K.	Checked mirror.....		<input type="checkbox"/>	<input type="checkbox"/>	<input type="checkbox"/>
L.	Turned head.....		<input type="checkbox"/>	<input type="checkbox"/>	<input type="checkbox"/>

Number of cones hit _____

Reaction time was adequate. YES NO

Vehicle remained under control at all time. YES NO

Describe negative actions or attitudes.

Failed to complete exercise because _____

All requirements were met. YES NO

GENERAL REMARKS:

Instructor's signature _____ Date _____

I have seen the completed form and have been given an explanation of my performance and rating.

Participant's signature _____ Date _____

THIS PAGE INTENTIONALLY LEFT BLANK.

RIGHTSIDE ROAD TURN

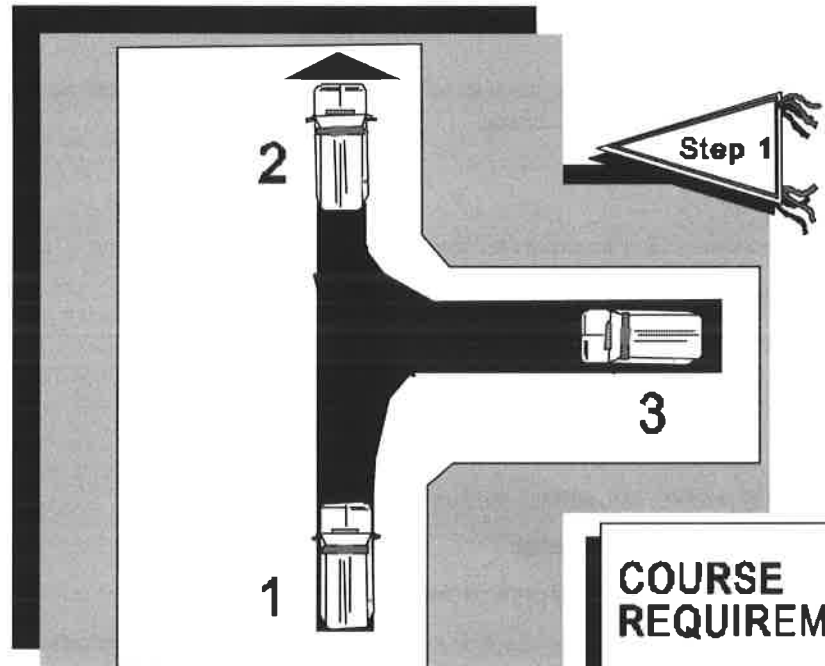

COURSE REQUIREMENTS

Set up exercise to simulate local roadway dimensions

Requires 50 traffic cones

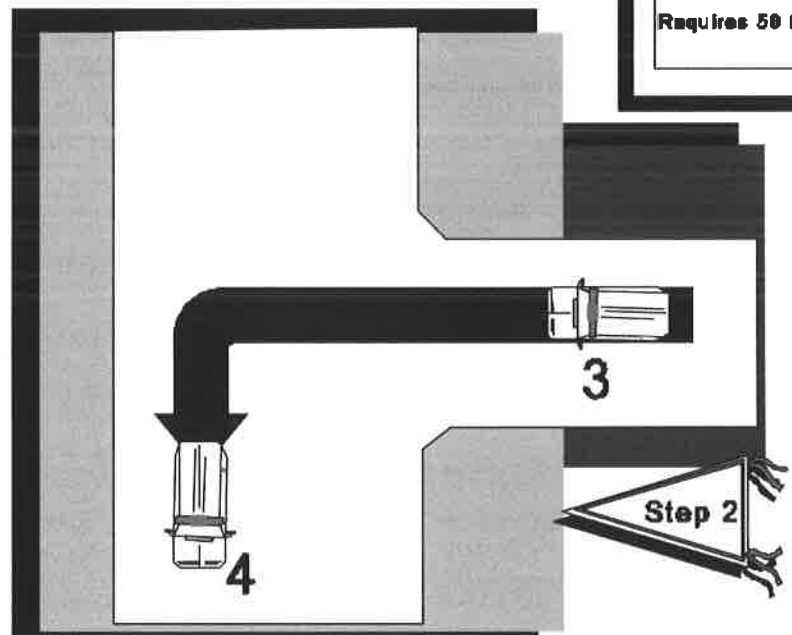

Right Side Road Turn

Purpose:

To develop the skill of coordinating turning, braking, signaling, and making traffic observations.

Procedure:

Enter course, slow, and stop just past side road. Back into side road. Stop with front bumper clear of roadway. Check traffic, signal, and pull into opposite lane. Accelerate and exit course.

Instructor:

1. Explains purpose of exercise and key factors of the exercise.
2. Demonstrates exercise at moderate speed.
3. Demonstrates exercise at required speed.

Participant:

1. Assumes proper driving position; seat, mirrors, seat belt.
2. Enters course at speed determined by instructor.
3. Selects side road, checks rear traffic, and signals for a stop at least 100 feet in advance.
4. Keeps close to right edge of road and brings vehicle to a stop approximately 10 feet past the side road.
5. Allows traffic from the rear to pass.
6. Looks over the right shoulder and rechecks traffic.
7. Backs into the side road on the right.
8. Checks traffic in both directions, signals for left turn and re-enters the roadway.
9. Negotiates the course smoothly.
10. Keeps steering movements constant and even.
11. Maintains 9 - 3 hand position.
12. Exits the course at the direction of the instructor.

Right Side Road Turn Exercise Rating

Participant's name _____ Date _____ Vehicle make/number _____

		<u>Practice Exercises</u>			
		1	2	3	4
A.	Entered course correctly.....	<input type="checkbox"/>	<input type="checkbox"/>	<input type="checkbox"/>	<input type="checkbox"/>
B.	Maintained required speed.....	<input type="checkbox"/>	<input type="checkbox"/>	<input type="checkbox"/>	<input type="checkbox"/>
C.	9 - 3 hand position (going forward).	<input type="checkbox"/>	<input type="checkbox"/>	<input type="checkbox"/>	<input type="checkbox"/>
D.	Controlled acceleration.....	<input type="checkbox"/>	<input type="checkbox"/>	<input type="checkbox"/>	<input type="checkbox"/>
E.	Steering control.....		<input type="checkbox"/>	<input type="checkbox"/>	<input type="checkbox"/>
F.	Accelerator, steering coordination....	<input type="checkbox"/>	<input type="checkbox"/>	<input type="checkbox"/>	<input type="checkbox"/>
G.	Smooth acceleration.....		<input type="checkbox"/>	<input type="checkbox"/>	<input type="checkbox"/>
H.	Foot movement.....		<input type="checkbox"/>	<input type="checkbox"/>	<input type="checkbox"/>
I.	Use of brakes.....		<input type="checkbox"/>	<input type="checkbox"/>	<input type="checkbox"/>
J.	Signaled intention.....		<input type="checkbox"/>	<input type="checkbox"/>	<input type="checkbox"/>
K.	Checked mirror.....		<input type="checkbox"/>	<input type="checkbox"/>	<input type="checkbox"/>
L.	Turned head.....		<input type="checkbox"/>	<input type="checkbox"/>	<input type="checkbox"/>

Number of cones hit _____

Reaction time was adequate. YES NO

Vehicle remained under control at all time. YES NO

Describe negative actions or attitudes.

Failed to complete exercise because _____

All requirements were met. YES NO

GENERAL REMARKS:

Instructor's signature _____ Date _____

I have seen the completed form and have been given an explanation of my performance and rating.

Participant's signature _____ Date _____

THIS PAGE INTENTIONALLY LEFT BLANK.

LEFTSIDE ROAD TURN

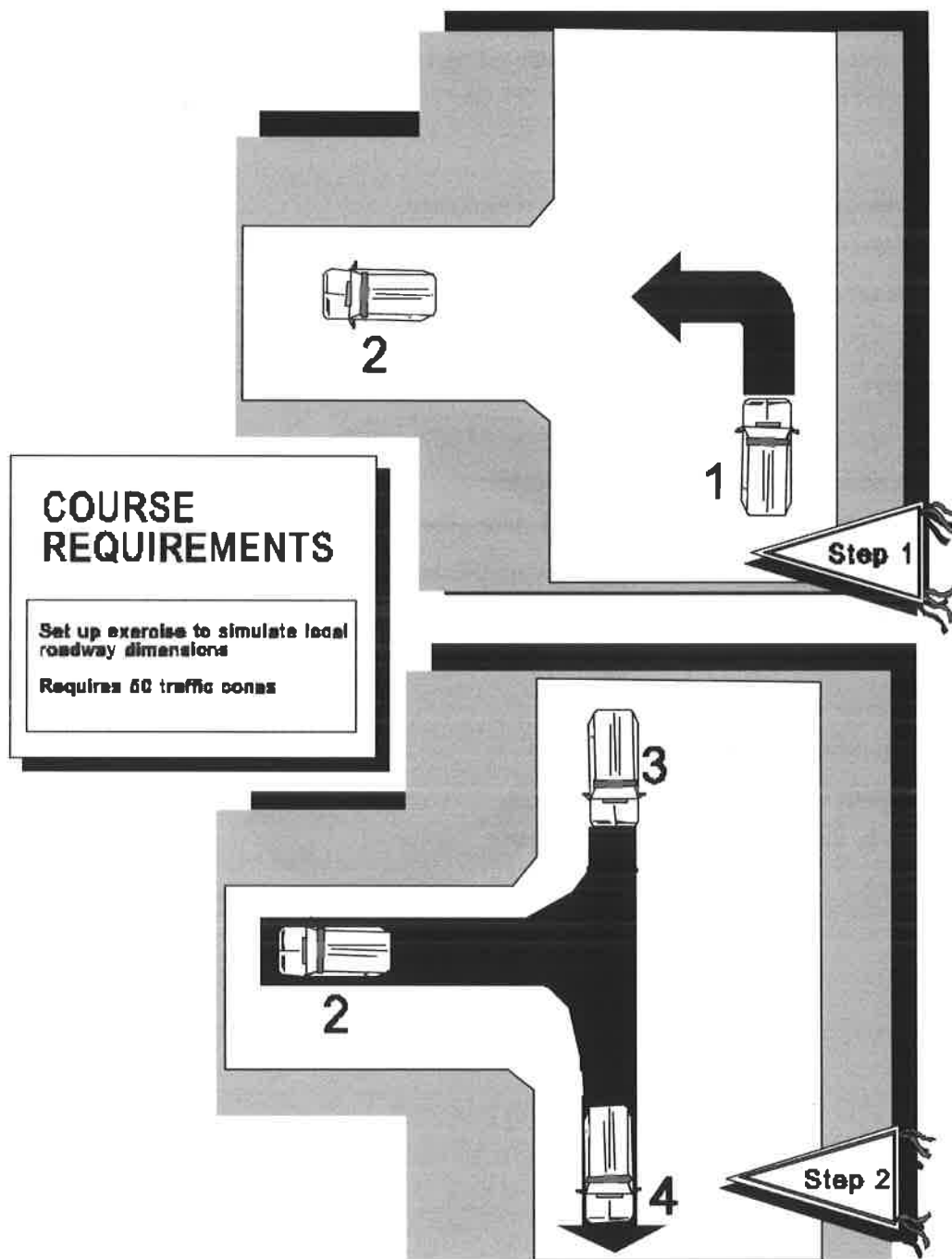

Left Side Road Turn

Purpose:

To develop the skill of coordinating turning, braking, signaling, and making traffic observations.

Procedure:

Enter course, slow, and signal for left turn. Check traffic and turn left into side road. Stop with rear bumper clear of roadway. Check traffic and back into lane. Stop. Accelerate forward and exit course.

Instructor:

1. Explains purpose of exercise and key factors of the exercise.
2. Demonstrates exercise at moderate speed.
3. Demonstrates exercise at required speed.

Participant:

1. Assumes proper driving position; seat, mirrors, seat belt.
2. Enters course at speed determined by instructor.
3. Selects side road, checks rear traffic, and signals for a turn at least 100 feet in advance.
4. Keeps to the right of the centerline and stops approximately 20 feet from roadway.
5. Checks traffic and proceeds ahead.
6. Moves forward.
7. Negotiates the course smoothly.
8. Keeps steering movements constant and even.
9. Maintains 9 - 3 hand position.
10. Exits the course at the direction of the instructor.

Left Side Road Turn Exercise Rating

Participant's name _____ Date _____ Vehicle make/number _____

		<u>Practice Exercises</u>			
		1	2	3	4
A.	Entered course correctly.....	<input type="checkbox"/>	<input type="checkbox"/>	<input type="checkbox"/>	<input type="checkbox"/>
B.	Maintained required speed.....	<input type="checkbox"/>	<input type="checkbox"/>	<input type="checkbox"/>	<input type="checkbox"/>
C.	9 - 3 hand position (going forward).	<input type="checkbox"/>	<input type="checkbox"/>	<input type="checkbox"/>	<input type="checkbox"/>
D.	Controlled acceleration.....	<input type="checkbox"/>	<input type="checkbox"/>	<input type="checkbox"/>	<input type="checkbox"/>
E.	Steering control.....		<input type="checkbox"/>	<input type="checkbox"/>	<input type="checkbox"/>
F.	Accelerator, steering coordination....	<input type="checkbox"/>	<input type="checkbox"/>	<input type="checkbox"/>	<input type="checkbox"/>
G.	Smooth acceleration.....		<input type="checkbox"/>	<input type="checkbox"/>	<input type="checkbox"/>
H.	Foot movement.....		<input type="checkbox"/>	<input type="checkbox"/>	<input type="checkbox"/>
I.	Use of brakes.....		<input type="checkbox"/>	<input type="checkbox"/>	<input type="checkbox"/>
J.	Signaled intention.....		<input type="checkbox"/>	<input type="checkbox"/>	<input type="checkbox"/>
K.	Checked mirror.....		<input type="checkbox"/>	<input type="checkbox"/>	<input type="checkbox"/>
L.	Turned head.....		<input type="checkbox"/>	<input type="checkbox"/>	<input type="checkbox"/>

Number of cones hit _____

Reaction time was adequate. YES NO

Vehicle remained under control at all time. YES NO

Describe negative actions or attitudes.

Failed to complete exercise because _____

All requirements were met. YES NO

GENERAL REMARKS:

Instructor's signature _____ Date _____

I have seen the completed form and have been given an explanation of my performance and rating.

Participant's signature _____ Date _____

THIS PAGE INTENTIONALLY LEFT BLANK.

SLOW SPEED LANE CHANGE

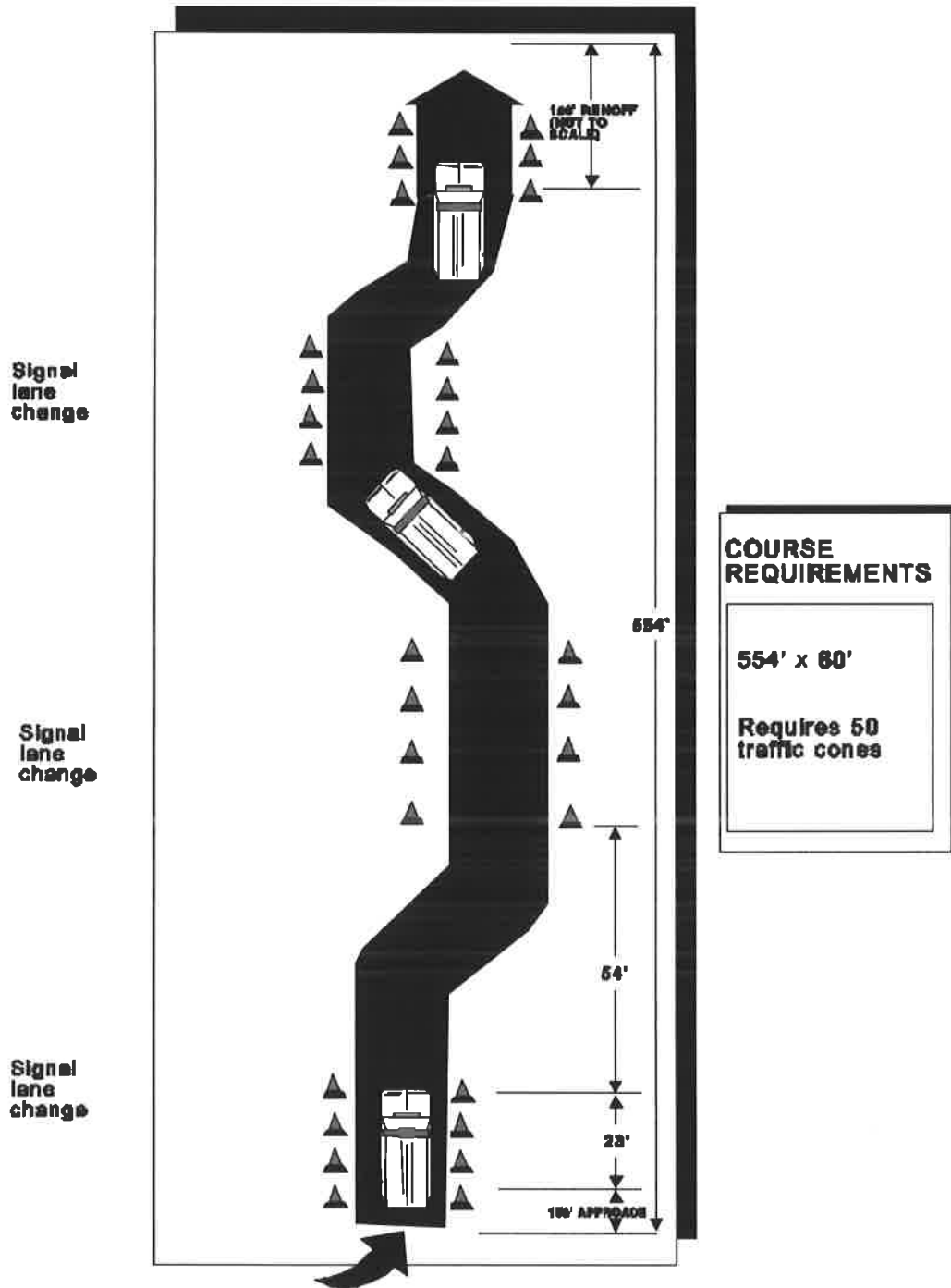

Slow Speed Lane Change

Purpose:

To develop confidence in controlling the vehicle and to experience vehicle stability. The exercise assists in developing coordination of steering and acceleration as well as the recognition of the relationship of fixed objects with respect to the vehicle.

Procedure:

Enter course at selected speed. Maintain speed as lane changes are made. Signal for turn when first entering lanes, change lanes, change signal for opposite lane change.

Instructor:

1. Explains purpose of exercise and key factors of the exercise.
2. Demonstrates exercise at moderate speed.
3. Demonstrates exercise at required speed.

Participant:

1. Assumes proper driving position; seat, mirrors, seat belt.
2. Enters course at speed determined by instructor.
3. Negotiates the course smoothly.
4. Keeps steering movements constant and even.
5. Maintains 9 - 3 hand position.
6. Maintains constant speed throughout the course.
7. Does not use brakes.
8. Passes closely to the cones.
9. Exits the course at the direction of the instructor.

Slow Speed Lane Change Exercise Rating

Participant's name _____ Date _____ Vehicle make/number _____

		<u>Practice Exercises</u>			
		1	2	3	4
A.	Entered course correctly.....	<input type="checkbox"/>	<input type="checkbox"/>	<input type="checkbox"/>	<input type="checkbox"/>
B.	Maintained required speed.....	<input type="checkbox"/>	<input type="checkbox"/>	<input type="checkbox"/>	<input type="checkbox"/>
C.	9 - 3 hand position.....		<input type="checkbox"/>	<input type="checkbox"/>	<input type="checkbox"/>
D.	Controlled acceleration.....	<input type="checkbox"/>	<input type="checkbox"/>	<input type="checkbox"/>	<input type="checkbox"/>
E.	Steering control.....		<input type="checkbox"/>	<input type="checkbox"/>	<input type="checkbox"/>
F.	Counter steering.....		<input type="checkbox"/>	<input type="checkbox"/>	<input type="checkbox"/>
G.	Accelerator, steering coordination....	<input type="checkbox"/>	<input type="checkbox"/>	<input type="checkbox"/>	<input type="checkbox"/>
H.	Checked mirrors.....		<input type="checkbox"/>	<input type="checkbox"/>	<input type="checkbox"/>
I.	Turned head.....		<input type="checkbox"/>	<input type="checkbox"/>	<input type="checkbox"/>
J.	Foot movement.....		<input type="checkbox"/>	<input type="checkbox"/>	<input type="checkbox"/>
K.	Use of brakes.....		<input type="checkbox"/>	<input type="checkbox"/>	<input type="checkbox"/>

Number of cones hit _____

Reaction time was adequate. YES NO

Vehicle remained under control at all time. YES NO

Describe negative actions or attitudes.

Failed to complete exercise because _____

All requirements were met. YES NO

GENERAL REMARKS:

Instructor's signature _____ Date _____

I have seen the completed form and have been given an explanation of my performance and rating.

Participant's signature _____ Date _____

THIS PAGE INTENTIONALLY LEFT BLANK.

PERPENDICULAR PARKING (BACKING)

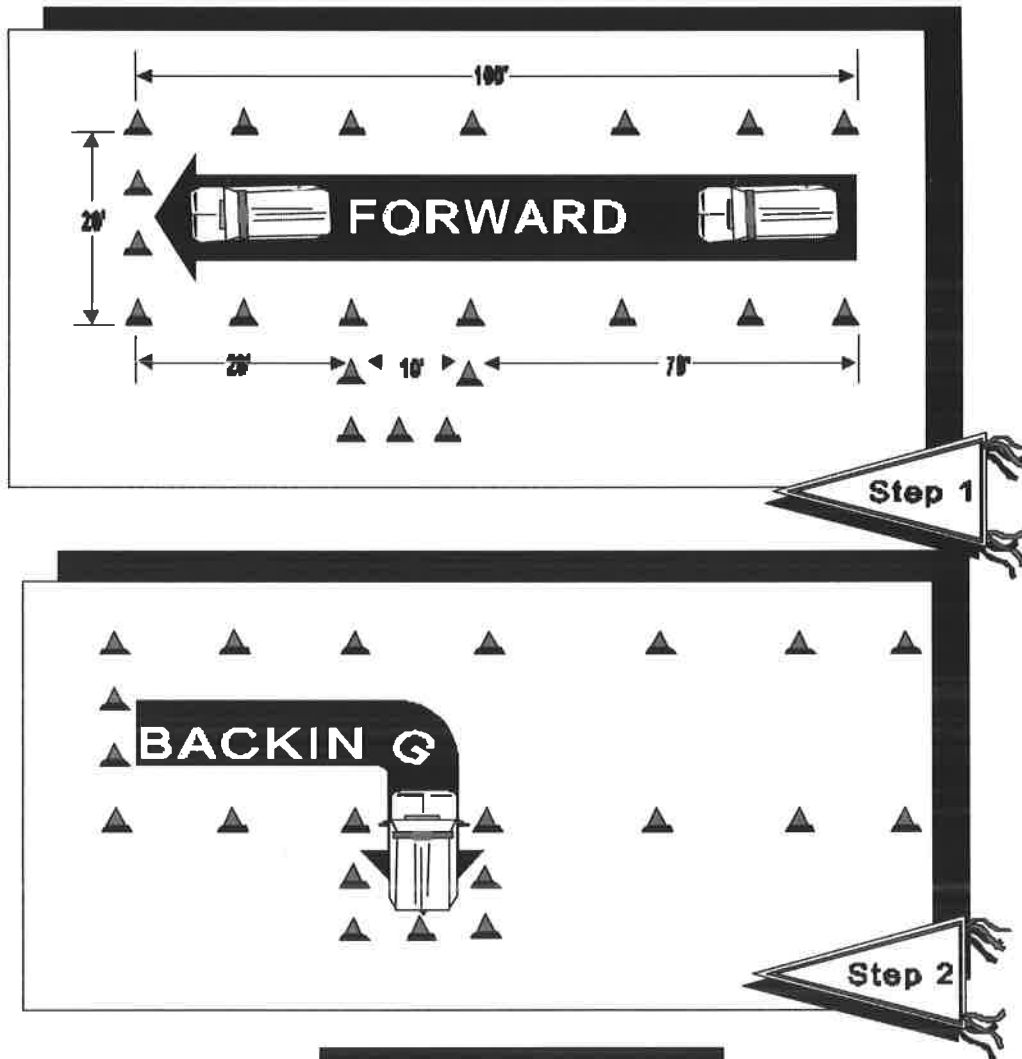

COURSE REQUIREMENTS

Set up cones to simulate local medical facility parking spaces

Option: Use vehicles to create parking space

Perpendicular Parking, Back In and Drive Out

Purpose:

To develop skill in backing a vehicle into a stall controlling front end swing and recognizing the relationship of the vehicle to fixed objects. Develops use of mirrors and use of ground guide and mirrors.

Procedure:

Drive forward at steady speed. Brake to stop at forward cone line. Back into space while turning. Stop at cone line. Maintain centerline of parking space. First tries to be conducted using mirrors only. Add ground guide for subsequent tries.

Instructor:

1. Explains purpose of exercise and key factors of the exercise.
2. Demonstrates exercise at moderate speed.
3. Demonstrates exercise at required speed.

Participant:

1. Assumes proper driving position; seat, mirrors, seat belt.
2. Enters course at speed determined by instructor.
3. Drives the vehicle beyond the stall, which is perpendicular to the road.
4. Backs the vehicle into the center of the stall.
5. Drives forward using the 9 - 3 steering method.
6. Turns into designated parking space using hand-over-hand or shuffle steering.
7. Centers vehicle in parking space.
8. Drives out, turning steering wheel to the desired direction selected.
9. Makes final adjustments and drives forward.
10. Exits course at direction of instructor.
11. Uses ground guide and proper hand signals.

Perpendicular Parking Exercise Rating Back In and Drive Out

Participant's name _____ Date _____ Vehicle make/number _____

		<u>Practice Exercises</u>			
		1	2	3	4
A.	Controlled acceleration.....	<input type="checkbox"/>	<input type="checkbox"/>	<input type="checkbox"/>	<input type="checkbox"/>
B.	Coordination of steering and braking....	<input type="checkbox"/>	<input type="checkbox"/>	<input type="checkbox"/>	<input type="checkbox"/>
C.	Foot movement.....	<input type="checkbox"/>	<input type="checkbox"/>	<input type="checkbox"/>	<input type="checkbox"/>
D.	Use of ground guide.....	<input type="checkbox"/>	<input type="checkbox"/>	<input type="checkbox"/>	<input type="checkbox"/>
E.	Use of proper hand signals.....	<input type="checkbox"/>	<input type="checkbox"/>	<input type="checkbox"/>	<input type="checkbox"/>

Number of cones hit _____

Reaction time was adequate. YES NO

Vehicle remained under control at all time. YES NO

Task was completed in one sequence of movements. YES NO

Vehicle was 12 inches or less from curb. YES NO

Describe negative actions or attitudes.

Failed to complete exercise because _____

All requirements were met. YES NO

GENERAL REMARKS:

Instructor's signature _____ Date _____

I have seen the completed form and have been given an explanation of my performance and rating.

Participant's signature _____ Date _____

THIS PAGE INTENTIONALLY LEFT BLANK.

MODULE C

AMBULANCE OPERATOR INTERNSHIP: GUIDELINES FOR ADDITIONAL ON-THE-JOB TRAINING AND DOCUMENTATION

MODULE GOAL

The goal of this module is to provide ambulance operators with the skills to safely and efficiently operate an ambulance while performing on-the-job training (OJT) runs.

MODULE OVERVIEW

This module builds on the knowledge and skills you learned in Modules A and B. You will now begin a series of supervised on-the-job training sessions. This training is necessary because there are operational tasks that cannot be evaluated in other than an operational setting. You may do an excellent job on the driving course but not be able to cope with an emergency response, traffic congestion, and navigating to different medical facilities. This is the final phase of the training to qualify as an ambulance operator. You should be assigned to a partner who is qualified to coach and evaluate your performance. Training should never stop. There is always something to learn or practice to maintain a professional level of performance.

ORIENTATION

An experienced person should conduct an orientation for you. This should include a complete discussion of the traffic situation in the operational area and practice runs without patients to the medical facilities. If there are any particular areas the organization responds to frequently, the reason for the responses should be explained and the best routes identified. Navigation training should begin and continue so that you can find the medical facilities from any location in the operational area. Throughout the OJT, the training manager will monitor your progress by discussing your progress with you and the supervisor and by reviewing the checklists. When the performance standard has been achieved in each phase of the OJT, you will be told and the entries made to your training record.

Each ambulance crew should continue training by practicing during every opportunity. They should also critique each run to review what they did that could be improved and to determine how the next run could be better.

If you have a busy organization that makes many runs daily, the OJT period may be completed in a few days. In less busy organizations, the training may take weeks. Try to get all training completed as soon as possible.

CHECKLIST ORGANIZATION

Each of the checklists listed below covers a related group of tasks that must be performed.

Checklists

Ambulance Familiarization
Ambulance Inspection, Maintenance, and Repair
Normal and High Risk Operating Situations
Operational Driving

Beside each task statement on the checklist is a series of boxes. The number of boxes signifies a projected number of times you might need to perform the task under supervision on an actual run. You may perform to the standard on the first run, and this should be indicated. Space is included on each checklist for the evaluator's comments. These comments provide a running narrative of your progress. The checklist should be filled out at the end of each run, and you should be briefed on your performance results. Completed checklists become a valuable training record, and they are placed in your permanent training record.

Depending on the tasks performed during each supervised run, the evaluator may be able to sign off task accomplishment on more than one checklist, and is encouraged to do so.

HOW TO USE THE CHECKLISTS

The checklists are designed to record how you did your job in an operational setting or simulated practice. The checklists show the tasks that you will be expected to perform during your on-the-job training. You can use the checklists as a study guide for your organization. You will need to study your organization's Standard Operating Procedures (SOP). The SOP will describe the procedures for a variety of routine situations that you will encounter and what to do when you need assistance. Take each checklist and try to match up the tasks with the information in the SOP. If the SOP does not cover a task, ask your supervisor to tell you how to do that task.

In an operational setting, the type of run will not be known until the ambulance is dispatched and the run is completed. During this time the crew must focus on doing the job. When the run is completed, the supervising crew member (evaluator) gets a copy of the checklist most appropriate for the type of run completed. In most cases, all of the tasks on the checklist will not be performed on a single run. The evaluator will go over the run with you in private.

It's always best for the evaluator to let you know if your performance was satisfactory or not. You will be briefed on your performance throughout your OJT. The evaluators should tell you what you did that was good and met the standard and any areas that you could improve. This should be a positive experience, and you should not challenge the evaluator or argue about your view of how you did. If you believe that the evaluator is being unfair, you can discuss what you think is unfair. If the evaluator says that you did not make a complete stop and clear the intersection properly before proceeding, then the chances are that you did not stop completely. The evaluator wants you to succeed and become a fully qualified ambulance operator. Evaluators also must ensure that you have demonstrated the skills, knowledge, proper attitude, and temperament in an operational setting.

When you have demonstrated satisfactory performance for a task, you get a check mark in the box. Leaving a box blank means the participant did not perform the task or was not observed by an evaluator when he did perform the task.

The organization training manager or supervisor should review all checklists and discuss your progress with the evaluators.

The designated authority to issue operator certificates will be notified when you have demonstrated satisfactory performance in all tasks. A certificate of completion should be issued to you, at an appropriate ceremony.

THE EVALUATOR

The evaluator should be the training supervisor or a person qualified to evaluate the participant's performance during actual runs. As with the driving range training in Module B, all evaluators are encouraged to maintain a positive, "let me help you succeed" attitude. If a participant does have difficulty with a certain aspect of ambulance operations, it is usually more beneficial to recommend additional practice in that area rather than eliminate the person as an operator. The evaluator's input and recommendations are invaluable in keeping a participant motivated and progressing during this final phase of training.

THIS PAGE INTENTIONALLY LEFT BLANK.

Ambulance Familiarization Checklist

Participant's name	Date	Vehicle make/number
A. Ambulance description (verbal)		1 2 3
1.	Ambulance Class.....	<input type="checkbox"/> <input type="checkbox"/> <input type="checkbox"/>
2.	Engine/transmission type.....	<input type="checkbox"/> <input type="checkbox"/> <input type="checkbox"/>
3.	Height.....	<input type="checkbox"/> <input type="checkbox"/> <input type="checkbox"/>
4.	Basic weight and load capacity.....	<input type="checkbox"/> <input type="checkbox"/> <input type="checkbox"/>
5.	Installed emergency lights, sirens, horns.....	<input type="checkbox"/> <input type="checkbox"/> <input type="checkbox"/>
6.	Installed life support equipment.....	<input type="checkbox"/> <input type="checkbox"/> <input type="checkbox"/>
7.	Other.....	<input type="checkbox"/> <input type="checkbox"/> <input type="checkbox"/>

Comments:

B. Use of installed equipment		1 2 3
1.	Auxiliary power unit.....	<input type="checkbox"/> <input type="checkbox"/> <input type="checkbox"/>
2.	On-scene floodlights.....	<input type="checkbox"/> <input type="checkbox"/> <input type="checkbox"/>
3.	Emergency lights, sirens, horns.....	<input type="checkbox"/> <input type="checkbox"/> <input type="checkbox"/>
4.	Operator compartment controls and switches.	<input type="checkbox"/> <input type="checkbox"/> <input type="checkbox"/>
5.	Other.....	<input type="checkbox"/> <input type="checkbox"/> <input type="checkbox"/>

Comments:

All requirements have been met. YES NO

Instructor's signature _____ Date _____

I have seen the completed checklist and have been given an explanation of my performance.

Participant's signature _____ Date _____

THIS PAGE INTENTIONALLY LEFT BLANK.

Ambulance Inspection, Maintenance, and Repair Checklist

Participant's name _____ Date _____ Vehicle make/number _____

- A. Quick Check
- | | | | | | |
|----|--|--------------------------|--------------------------|--------------------------|--------------------------|
| | | 1 | 2 | 3 | 4 |
| 1. | Use of checklist..... | <input type="checkbox"/> | <input type="checkbox"/> | <input type="checkbox"/> | <input type="checkbox"/> |
| 2. | Documentation of discrepancies..... | | <input type="checkbox"/> | <input type="checkbox"/> | <input type="checkbox"/> |
| 3. | Completion of Work Request..... | | <input type="checkbox"/> | <input type="checkbox"/> | <input type="checkbox"/> |
| 4. | Appropriate vehicle in-service decision..... | | <input type="checkbox"/> | <input type="checkbox"/> | <input type="checkbox"/> |
| 5. | Recordkeeping..... | <input type="checkbox"/> | <input type="checkbox"/> | <input type="checkbox"/> | <input type="checkbox"/> |

Comments:

- B. Full check
- | | | | | | |
|----|--|--------------------------|--------------------------|--------------------------|--------------------------|
| | | 1 | 2 | 3 | 4 |
| 1. | Use of checklist..... | <input type="checkbox"/> | <input type="checkbox"/> | <input type="checkbox"/> | <input type="checkbox"/> |
| 2. | Documentation of discrepancies..... | | <input type="checkbox"/> | <input type="checkbox"/> | <input type="checkbox"/> |
| 3. | Completion of Work Request..... | | <input type="checkbox"/> | <input type="checkbox"/> | <input type="checkbox"/> |
| 4. | Appropriate vehicle in-service decision..... | | <input type="checkbox"/> | <input type="checkbox"/> | <input type="checkbox"/> |
| 5. | Recordkeeping..... | <input type="checkbox"/> | <input type="checkbox"/> | <input type="checkbox"/> | <input type="checkbox"/> |

Comments:

- C. Maintenance and Repair
- | | | | | |
|----|---|--------------------------|--------------------------|--------------------------|
| | | 1 | 2 | 3 |
| 1. | Use of Work Request..... | <input type="checkbox"/> | <input type="checkbox"/> | <input type="checkbox"/> |
| 2. | Preventive maintenance program..... | | <input type="checkbox"/> | <input type="checkbox"/> |
| 3. | Maintenance and repair follow-up..... | | <input type="checkbox"/> | <input type="checkbox"/> |
| 4. | Maintenance procedures for enroute malfunctions | | <input type="checkbox"/> | <input type="checkbox"/> |

Comments:

All requirements have been met. YES NO

Instructor's signature _____ Date _____

I have seen the completed checklist and have been given an explanation of my performance.

Participant's signature _____ Date _____

THIS PAGE INTENTIONALLY LEFT BLANK.

Normal and High Risk Situations Checklist

Participant's name	Date	Vehicle make/number
A.	Ambulance Operation Under Normal Conditions	1 2 3 4 5
1.	Road surfaces--asphalt, concrete, gravel, transition	<input type="checkbox"/> <input type="checkbox"/> <input type="checkbox"/>
2.	Road surfaces--bumps, mud, potholes, misc. objects	<input type="checkbox"/> <input type="checkbox"/> <input type="checkbox"/>
3.	Road construction--bridges, ramps, curves	<input type="checkbox"/> <input type="checkbox"/> <input type="checkbox"/>
4.	Cornering skills.....	<input type="checkbox"/> <input type="checkbox"/> <input type="checkbox"/> <input type="checkbox"/>
5.	Braking skills.....	<input type="checkbox"/> <input type="checkbox"/> <input type="checkbox"/> <input type="checkbox"/>
6.	Accelerating skills.....	<input type="checkbox"/> <input type="checkbox"/> <input type="checkbox"/> <input type="checkbox"/>
7.	Speed Control.....	<input type="checkbox"/> <input type="checkbox"/> <input type="checkbox"/> <input type="checkbox"/>
8.	Lane changes.....	<input type="checkbox"/> <input type="checkbox"/> <input type="checkbox"/> <input type="checkbox"/>
9.	Passing other vehicles.....	<input type="checkbox"/> <input type="checkbox"/> <input type="checkbox"/> <input type="checkbox"/>
10.	Backing--uses ground guide.....	<input type="checkbox"/> <input type="checkbox"/> <input type="checkbox"/> <input type="checkbox"/> <input type="checkbox"/>
11.	Parking.....	<input type="checkbox"/> <input type="checkbox"/> <input type="checkbox"/> <input type="checkbox"/>
12.	Turning around.....	<input type="checkbox"/> <input type="checkbox"/> <input type="checkbox"/> <input type="checkbox"/>
13.	Operating on two-lane roads.....	<input type="checkbox"/> <input type="checkbox"/> <input type="checkbox"/>
14.	Operating on interstate highways.....	<input type="checkbox"/> <input type="checkbox"/> <input type="checkbox"/>
15.	Overall ambulance control.....	<input type="checkbox"/> <input type="checkbox"/> <input type="checkbox"/> <input type="checkbox"/>
16.	Use of lights and turn signals.....	<input type="checkbox"/> <input type="checkbox"/> <input type="checkbox"/> <input type="checkbox"/>
17.	Use of mirrors.....	<input type="checkbox"/> <input type="checkbox"/> <input type="checkbox"/> <input type="checkbox"/>

Comments:

B.	Ambulance operation under high risk conditions	1 2 3 4 5
1.	Use of lights and siren.....	<input type="checkbox"/> <input type="checkbox"/> <input type="checkbox"/> <input type="checkbox"/> <input type="checkbox"/>
2.	Compliance with state and local regulations for emergency vehicles.....	<input type="checkbox"/> <input type="checkbox"/> <input type="checkbox"/> <input type="checkbox"/> <input type="checkbox"/>
3.	Adherence to speed limits.....	<input type="checkbox"/> <input type="checkbox"/> <input type="checkbox"/> <input type="checkbox"/> <input type="checkbox"/>
4.	Maintains safety cushion.....	<input type="checkbox"/> <input type="checkbox"/> <input type="checkbox"/> <input type="checkbox"/> <input type="checkbox"/> <input type="checkbox"/>
5.	Use of 2-4-12 Rule.....	<input type="checkbox"/> <input type="checkbox"/> <input type="checkbox"/> <input type="checkbox"/> <input type="checkbox"/>
6.	Drives defensively.....	<input type="checkbox"/> <input type="checkbox"/> <input type="checkbox"/> <input type="checkbox"/> <input type="checkbox"/>
7.	Response to potential crash situations.....	<input type="checkbox"/> <input type="checkbox"/> <input type="checkbox"/>
8.	Communicates with other drivers.....	<input type="checkbox"/> <input type="checkbox"/> <input type="checkbox"/> <input type="checkbox"/> <input type="checkbox"/>

Checklists

-
- 9. Performs pre-crash planning.....
 - 10. Controlled intersections
 - a. Use of lights and siren.....
 - b. Approaches intersection cautiously
 - c. Communicates with other drivers..
 - d. Looks to clear all other traffic.....
 - e. Anticipates reactions of other drivers
 - f. Moves through intersections with caution.....
 - 11. Compliance with Law of Due Regard.....
 - 12. Driving against traffic.....
 - 13. Adverse weather
 - a. Preparation of ambulance.....
 - b. Response to visibility problems....
 - c. Response to traction problems.....
 - d. Response to high winds.....
 - 14. Night driving
 - a. Maintains night vision capabilities.
 - b. Use of headlights.....
 - c. Ambulance control at night.....
 - 15. Response when ambulance runs off the edge of the road.....
 - 16. Response to enroute malfunctions
 - a. Control of ambulance.....
 - b. Pulling off the road and parking..
 - c. Maintenance performed.....

Comments:

All requirements have been met. YES NO

Instructor's signature _____ Date _____ I have seen the completed checklist and have been given an explanation of my performance.

Participant's signature _____ Date _____

Operational Driving Checklist

Participant's name _____ Date _____ Vehicle make/number _____

- A. Pre-run phase
- | | 1 | 2 | 3 |
|---|--------------------------|--------------------------|--------------------------|
| 1. Ensures personal and crew readiness..... | <input type="checkbox"/> | <input type="checkbox"/> | <input type="checkbox"/> |
| 2. Ensures readiness of ambulance..... | <input type="checkbox"/> | <input type="checkbox"/> | <input type="checkbox"/> |
| 3. Plans primary and alternate routes..... | <input type="checkbox"/> | <input type="checkbox"/> | <input type="checkbox"/> |

Comments:

- B. Operations phase
- | | 1 | 2 | 3 |
|--|--------------------------|--------------------------|--------------------------|
| 1. Completes departure procedures..... | <input type="checkbox"/> | <input type="checkbox"/> | <input type="checkbox"/> |
| 2. Operation of ambulance enroute to the scene | <input type="checkbox"/> | <input type="checkbox"/> | <input type="checkbox"/> |
| 3. Assists EMT at the scene..... | <input type="checkbox"/> | <input type="checkbox"/> | <input type="checkbox"/> |
| 4. Performs required emergency scene operations | <input type="checkbox"/> | <input type="checkbox"/> | <input type="checkbox"/> |
| 5. Operation of ambulance enroute to medical facility..... | <input type="checkbox"/> | <input type="checkbox"/> | <input type="checkbox"/> |
| 6. Performs required operations at the medical facility..... | <input type="checkbox"/> | <input type="checkbox"/> | <input type="checkbox"/> |

Comments:

- C. Use of radio
- | | 1 | 2 | 3 |
|---------------------------------------|--------------------------|--------------------------|--------------------------|
| 1. Operation and test..... | <input type="checkbox"/> | <input type="checkbox"/> | <input type="checkbox"/> |
| 2. Frequency selection..... | <input type="checkbox"/> | <input type="checkbox"/> | <input type="checkbox"/> |
| 3. Security..... | <input type="checkbox"/> | <input type="checkbox"/> | <input type="checkbox"/> |
| 4. Required calls..... | <input type="checkbox"/> | <input type="checkbox"/> | <input type="checkbox"/> |
| 5. Complete and concise messages..... | <input type="checkbox"/> | <input type="checkbox"/> | <input type="checkbox"/> |
| 6. Use of phonetic alphabet..... | <input type="checkbox"/> | <input type="checkbox"/> | <input type="checkbox"/> |

Comments:

D. Verbal communications

1 2 3

- 1. With EMT enroute to scene.....
- 2. With individuals at the scene.....
- 3. With EMT enroute medical facility.....

Comments:

E. Post-run phase

1 2 3

- 1. Resupplies ambulance.....
- 2. Cleans and decontaminates ambulance.....
- 3. Prepares ambulance for next run.....

Comments:

All requirements have been met. YES NO

Instructor's signature _____ Date _____

I have seen the completed checklist and have been given an explanation of my performance.

Participant's signature _____ Date _____

Appendix A

Area Motor Vehicle Operations Guidelines

RELEVANT STATE STATUTES	
Motor Vehicle Code, State of _____	
Topic	Local Policy/Ordinance
<u>Definition of Emergency Vehicle</u>	
<u>Proceeding past red lights and stop signals</u>	
<u>Recognized warning devices</u>	

RELEVANT STATE STATUTES	
Motor Vehicle Code, State of _____	
Topic	Local Policy/Ordinance
<u>Violating traffic flow and turn regulations</u>	
<u>Passing</u>	
<u>Parking at the scene of an emergency</u>	

RELEVANT STATE STATUTES	
Motor Vehicle Code, State of _____	
Topic	Local Policy/Ordinance
<u>Exceeding posted speed limits</u>	
<u>Definition of an emergency</u>	

--	--

RELEVANT STATE STATUTES	
Motor Vehicle Code, State of _____	
Topic	Local Policy/Ordinance

--	--

Appendix B

Interpreting Hand Signals

Signal No. 1 Come Ahead

Day

Extend arms in front of your body, palms facing up. Move arms toward your body, bending at the elbows.

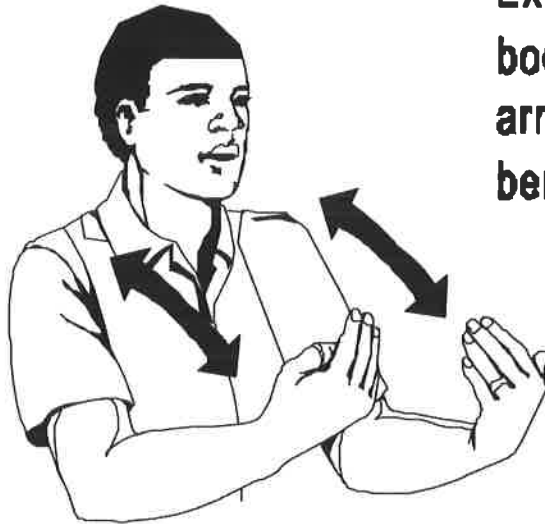

Night

When using conventional flashlights, direct lights forward.



Signal No. 2 Slow Down

Day

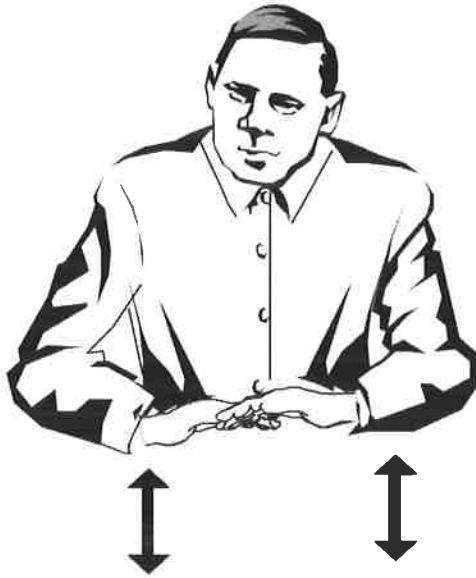

Turn palms facing downward with thumbs toward your body at waist level. Move hands down and up.

Night

When using conventional flashlights, direct lights forward.

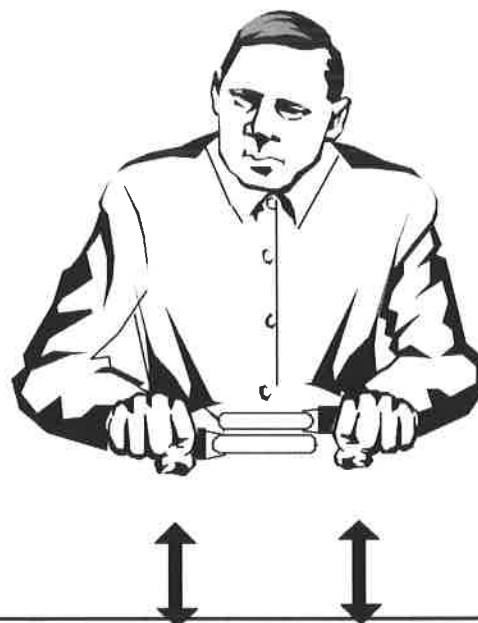

Signal No. 3 Stop or Halt

Day

Extend right arm forward with palm facing outward.



Night

Light in right hand pointed upward, blinking. When using conventional flashlights, direct light in right hand forward, blinking.

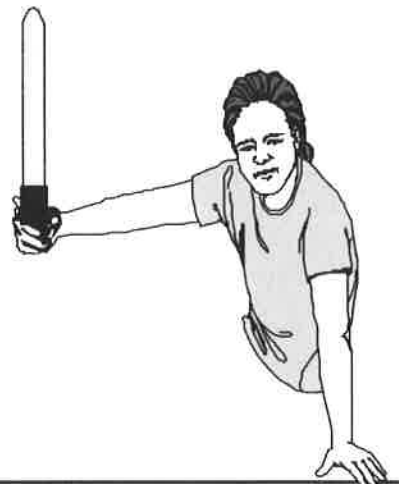

Signal No. 4 Move in Reverse

Day

Extend both arms in front of you, palm facing forward. Move hands forward and back.



Night

When using conventional flashlights, direct lights forward.



Signal No. 5 Turn Left

Day

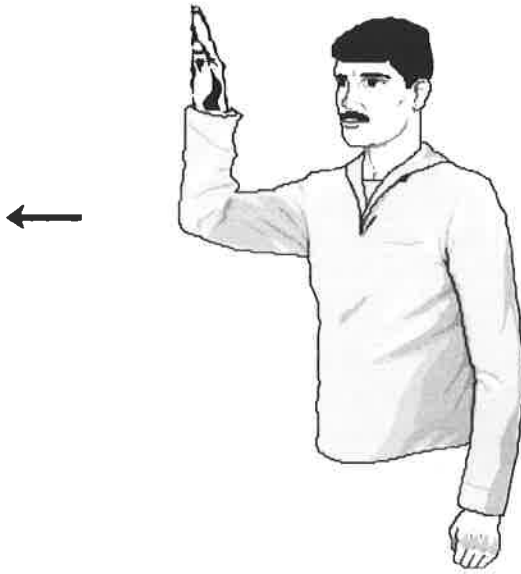

Facing the vehicle, raise right arm to your side, bending at the elbow. Face palm outward and move hand to your right.

Night

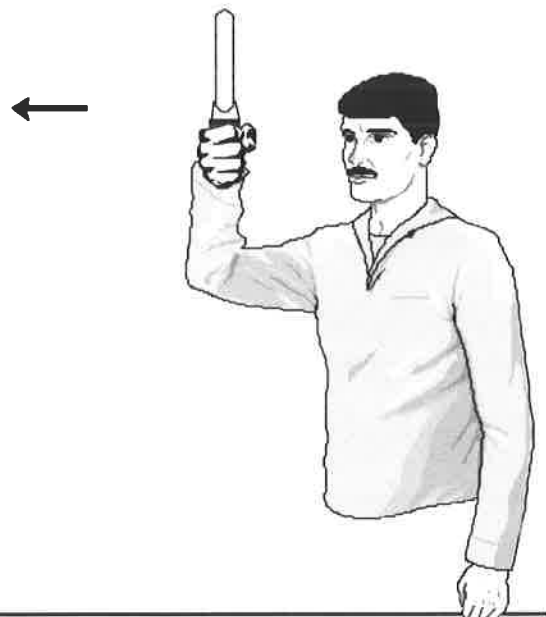

When using conventional flashlights, direct light in right hand forward.

Signal No. 6 Turn Right

Day

Facing the vehicle, raise left arm to your side bending at the elbow. Face palm outward and move hand to your left.

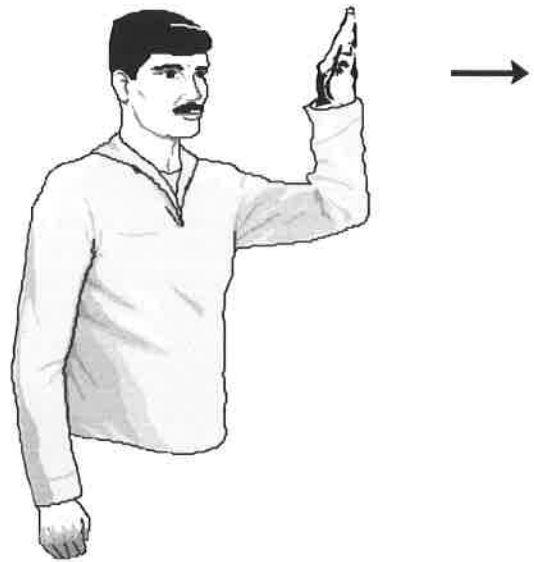

Night



When using conventional flashlights, direct light in left hand forward.

Signal No. 7 Turn Off Engine

Day

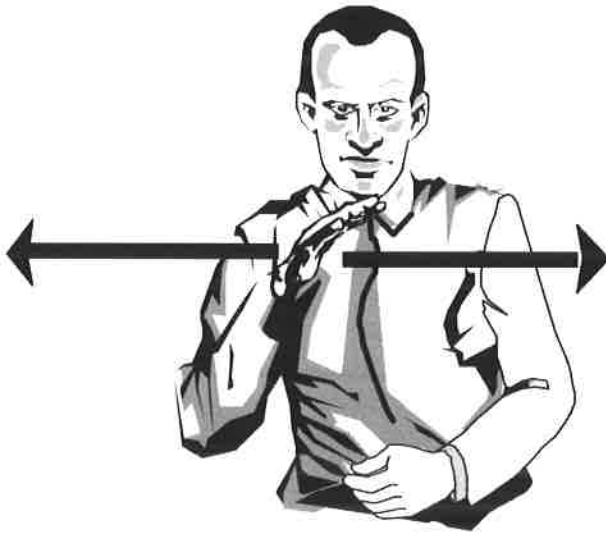

Place right hand above chest level, with elbow at your side, and palm facing downward. Move hand from right to left.

Night

When using conventional flashlights, direct light in right hand forward.



Signal No. 8 Increase Speed



Extend right arm above you with a closed fist, palm forward. Move arm up down and up in front of your body.

Night



When using conventional flashlights, direct light in right hand forward.



Signal No. 9 Start Engines

Day



Circle your right arm clockwise in front of your body.

Night

When using conventional flashlights, direct light in right hand forward.



Signal No. 10 As You Were

Day



Extend arms above your head; cross and uncross your hands at the wrists.

Night



When using conventional flashlights, direct lights forward.

Signal No. 11 Attention

Day



Extend right arm above you, palm facing outward. Wave hand right and left above your head.

Night

When using conventional flashlights, direct light in right hand forward.



Appendix C

Sample Checklist: Quick Check

SAMPLE CHECKLIST: QUICK CHECK

UNIT NUMBER: _____ STATION: _____ DATE: _____ TIME: _____

- Instructions:**
- Inspect each item and check ✓ OK if there are no problems.
 - If you find a problem, fix it and list repairs under Work Completed, OR file work request.
 - Decide whether or not to place the vehicle in service. Sign and date the checklist.
 - Any starred (*) problem must be fixed before the ambulance is placed in service.

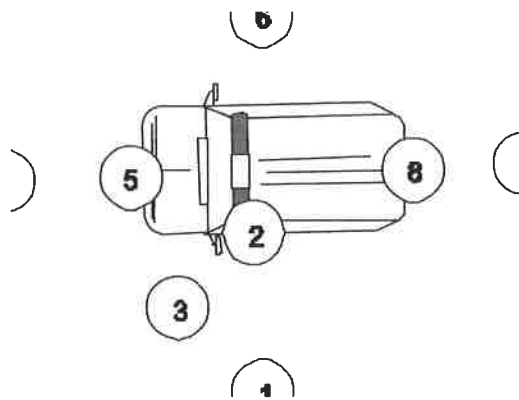

- 1) Overall Appearance
- 2) Operator Compartment
- 3) Exterior: Operator's Side
- 4) Exterior: Front
- 5) Engine Compartment
- 6) Exterior: Passenger's Side
- 7) Exterior: Rear
- 8) Patient Compartment

Items	Check	Problem	OK ✓	Work Reques t ✓	Work Completed/Ot her Remarks
OVERALL APPEARANCE (1)					
Vehicle	Cleanliness				

Items	Check	Problem	OK ✓	Work Reques t ✓	Work Completed/Ot her Remarks
	General Condition				
OPERATOR COMPARTMENT (2)					
Interior	Items Properly Stowed				
Vehicle Log	Previous Inspection Forms, Blank Run Forms				
Lights and Communication Equipment	Switches "OFF"				
Seat, Belt, Mirrors	Adjust				
Hood Latch	Release				
Fuel Gauge	Check Fuel Quantity				
EXTERIOR: OPERATOR'S SIDE (3)					
Mirror Bracket	Condition				
Side Window	Condition				
Windshield/Wiper	Condition				
Front Wheel/Tire	Condition, Inflation				
Front Fender	Condition				
EXTERIOR: FRONT (4)					
Hood, Bumper, Grill	Condition, Remove Debris				
Antennas	Condition				
Headlights, Turn Signals	Lens Condition				
Emergency Lights	Lens Condition				

Items	Check	Problem	OK ✓	Work Reques t ✓	Work Completed/Ot her Remarks
ENGINE COMPARTMENT (5)					
Engine	Signs of Leaks				
Belts	Condition				
Battery(ies)	Condition				
Fluids (Engine, Transmission, Cooling System, Windshield Washer)	Levels				
Hood	Latched				
EXTERIOR: PASSENGER'S SIDE (6)					
Front Fender	Condition				
Front Wheel/Tire	Condition, Inflation				
Windshield/Wiper	Condition				
Side Window	Condition				
Mirror Bracket	Condition				
Rear Fender	Condition				
Rear Wheel/Tire	Condition, Inflation				
PATIENT COMPARTMENT (7)					
General	Condition				
Doors	Latched				
EXTERIOR: REAR (8)					
Emergency Lights	Lens Condition				
Lights/Turn Signals	Lens Condition				

Items	Check	Problem	OK ✓	Work Reques † ✓	Work Completed/Ot her Remarks
Flood Lights	Lens Condition				
Rear Fender	Condition				
Rear Wheel/Tire	Condition, Inflation				

I have completed the above inspection. This vehicle should / should not be placed into service.

NAME: _____ **DATE:** _____

Appendix D

Sample Checklist: Full Check

SAMPLE CHECKLIST: FULL CHECK

UNIT NUMBER: _____ STATION: _____ DATE: _____ TIME: _____

Instructions:

- Inspect each item and check ✓ OK if there are no problems.
- If you find a problem, fix it and list repairs under Work Completed, or file work request
- Decide whether or not to place the vehicle in service. Sign and date the checklist.
- Any starred (*) problem must be fixed before the ambulance is placed in service.

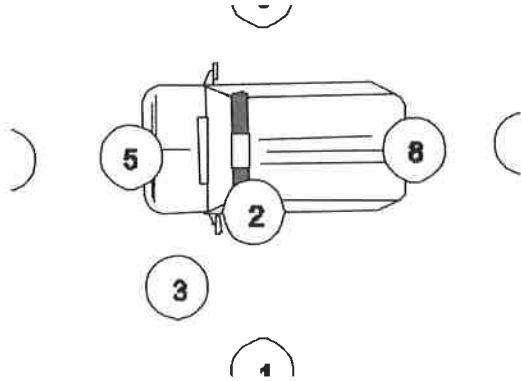

- 1) Overall Appearance
- 2) Operator Compartment
- 3) Exterior: Operator's Side
- 4) Exterior: Front
- 5) Engine Compartment
- 6) Exterior: Passenger's Side
- 7) Exterior: Rear
- 8) Patient Compartment

Items	Check	Problem	OK ✓	Work Request ✓	Work Completed/O ther Remarks
OVERALL APPEARANCE (1)					
Vehicle	Cleanliness				
	Body Lean/Balance				
	Leaks				
	Damage				
	Paint				
	General Condition				
OPERATOR COMPARTMENT (2)					
Interior	Items Properly Stowed				
Vehicle Log	Previous Inspection Forms, Blank Run Forms				
DMV Registration,	On Board				

Items	Check	Problem	OK ✓	Work Request ✓	Work Completed/O ther Remarks
Insurance Card					
Flashlight/lantern	On Board				
Maps	On Board				
Emergency Brake	Adjustment, Operation				
Lights (Check With Guide)	Condition, Lens, Operation, Then "OFF"				
Headlights					
Parking Lights					
Turn Signals					
Clearance Lights					
Hazard Lights					
Emergency Lights					
Spot Lights					
Flood Lights					
Tail Lights					
Brake Lights					
Back Up Lights					
Rear Step Lights					
License Plate Lights					
Side Lights					
Interior Lights					
Dash Lights					
Radio Equipment	Operation, Then"OFF"				
PA System	Operation, Then"OFF"				
Vehicle Locator System	Operation, Then "OFF"				
Vehicle Data Terminal	Operation, Then "OFF"				
Seats	Condition, Adjust				
Seat Belts	Condition, Adjust				
Mirrors	Condition, Adjust				
Air Horn	Operation				
Siren	Operation, All Modes				
Gauges (Check After Starting Engine)	Operation, Readings				
Electrical Charging					

Items	Check	Problem	OK ✓	Work Request ✓	Work Completed/O ther Remarks
System					
Auxiliary Generator/Inverter					
Brakes					
Fuel					
Oil Pressure					
Tachometer					
Engine Temperature					
Windshield Washer					
Windshield Wipers					
Hood Latch	Release				
EXTERIOR: OPERATOR'S SIDE (3)					
Door	Condition, Alignment				
Mirror Bracket	Condition				
Side Window	Condition				
Windshield/Wiper	Condition				
Front Wheel	Condition, Lug Nut Tightness				
Tire	Condition, Tire Inflation Reading, Tread Depth				
Front Fender	Condition				
EXTERIOR: FRONT (4)					
Hood, Bumper, Grill	Condition, Remove Debris				
Antennas	Condition				
ENGINE COMPARTMENT (5)					
Engine	Signs of Leaks				
Belts	Condition, Tension				
Battery(ies)	Condition, Water Level, Hydrometer Check, Terminals, Cables				
Fluids (Engine, Transmission, Cooling System, Windshield Washer, Brakes, Power-Steering)	Condition, Levels				
Hoses/Lines	Condition				
Hood	Latched				

Items	Check	Problem	OK ✓	Work Request ✓	Work Completed/O ther Remarks
EXTERIOR: PASSENGER'S SIDE (6)					
Front Fender	Condition				
Front Wheel	Condition, Lug Nut Tightness				
Tire	Condition, Tire Inflation Reading, Tread Depth				
Windshield and Wiper	Condition				
Side Window	Condition				
Mirror Bracket	Condition				
Door	Condition, Alignment				
Rear Fender	Condition				
Rear Wheel	Condition, Lug Nut Tightness				
Tire	Condition, Tire Inflation Reading, Tread Depth				
PATIENT COMPARTMENT (7)					
General	Condition, Equipment Stowed				
Fire Extinguishers	Quantity, Charge Level, Inspection Date				
Battery Jumper Cables	On Board				
Road Flares	Quantity On Board				
Medical Equipment	Inventory, Properly Stowed				
Doors	Latched				
EXTERIOR: REAR (8)					
Emergency Lights	Lens Condition				
Lights and Turn Signals	Lens Condition				
Flood Lights	Lens Condition				
Rear Fender	Condition				
Rear Wheel	Condition, Lug Nut Tightness				
Tire	Condition, Tire Inflation Reading, Tread Depth				

Items	Check	Problem	OK ✓	Work Request ✓	Work Completed/Other Remarks
Spare tire, tools	Condition, On board				

I have completed the above inspection. This vehicle should / should not be placed into service.

NAME: _____ **DATE:** _____

Appendix E
Sample Work Request

SAMPLE WORK REQUEST

COMPANY NAME		MILEAGE		TIME	WORK REQUEST NUMBER			
UNIT #	LIC. #				TIME IN:	TIME OUT:		
REPORTED PROBLEMS:				WORK PERFORMED	MECHANIC'S SIGNATURE	LABOR HOURS	HOURLY COST	LABOR COST
1:								
2:								
3:								
4:								
SIGNATURE OF OPERATOR		DATE		PARTS AND SUPPLIES		DESCRIPTION	PART #	COST
OFF DUTY PHONE #:								
ON EMERGENCY RUN		YES	NO					
PREVENTIVE MAINTENANCE								
INTERIOR CLEANED		Y						
EXTERIOR CLEANED		Y						
BRAKES CHECKED		Y						
TIRES CHECKED		Y						
BATTERY(IES) CHECKED		Y						
EMERGENCY SIGNALING EQUIPMENT CHECKED		Y						
LABOR TOTAL								
PARTS AND SUPPLIES TOTAL								
TOTAL COST								

Appendix F Glossary

Source: "*Standard Guide for Scope of Performance of Emergency Medical Services Ambulance Operations.*" ASTM, F1517, April 1994.

Term	Definition
ambulance operations	the efficient delivery of the ambulance, equipment, crew, passengers and patients, during all phases of the delivery of EMS involving the ambulance, at all times exercising the highest degree of care for the safety of the public
ambulance service provider	a person, company, corporation, or political entity responsible for operation, maintenance and/or policy making regarding emergency vehicle operations
Bona Fide Occupational Qualification (BFOQ)	the skills and knowledge relevant to the performance of a specific task
departure check	the visual check of the vehicle and surrounding area ensuring that equipment and supplies have been retrieved and properly stored and that all compartment doors are secured
egress check	the visual check of the vehicle and surrounding area prior to operating the ambulance
emergency mode	as defined by individual state statutes that refer to emergency vehicles, equipment and operations
full check	a comprehensive and systematic evaluation of the ambulance at specified intervals, including documentation of the inspection, deficiencies, and corrective actions
operator	a person who operates or assists with the operation of an ambulance
prerun	all aspects of assuring response readiness
postrun	the managed return of the ambulance and operators to optimal pre-run readiness
quick check	an abbreviated version of the full check, focusing on the

Term

Definition

major operational functions of the vehicle

Appendix G References

The following references were used in course development:

American Society for Testing and Materials. *Standard Guide for Performance of Emergency Medical Services Ambulance Operators*. Atlanta Draft. 20 April, 1993.

American Society for Testing and Materials. *Standard Guide for Training Emergency Medical Services Ambulance Operators*. Las Vegas Draft #4. 11-13 February, 1994.

AzStar Center for Safety & Risk Management Operator/Driver Instructor Course. AzStar Casualty Co. Version IV. August 1991.

Childs, B., and D. Ptacnik. *Emergency Ambulance Driving*. Englewood Cliffs, NJ: Prentice Hall, 1986.

Driver Marine Division. *Vehicle Dynamics*. Glynco, GA: Federal Law Enforcement Training Center.

Emergency Medical Services Program. *Ambulance Accident Prevention Seminar*. New York State Department of Health.

Grant, H.D. R.H. Murray, and J.D. Bergeron. *Brady Emergency Care*. 5th ed. Englewood Cliffs, NJ: Prentice Hall, 1990.

Klein, M.E. *Emergency Vehicle Operator's Course*. Apopka, FL: Florida Central Educational Clinic, 1993.

Minnesota Dept. of Public Safety. *Emergency Vehicle Driving Program*. St. Paul: Minnesota Technical College System.

United States. Dept. of Transportation, National Highway Traffic Safety Administration. *Training Program for Operation of Emergency Vehicles*.

United States. General Services Administration, Federal Supply Service. *KKK-A-1822C Federal*

Specification for Ambulances. Washington: Federal Supply Service, 1 January 1990.

Other Recommended Reference Materials

FEDERAL

National Safety Council. *Coaching the Emergency Vehicle Operator*. Princeton, NJ:FLI Learning Systems, Inc. 1991.

United States. Dept. of Transportation, National Highway Traffic Safety Administration. *Emergency Vehicle Operator Courses & Materials*. March 1992.

United States. Dept. of Transportation, National Highway Traffic Safety Administration. *Emergency Medical Services: First Responder Training Course* (formerly titled: Crash Injury Management for Traffic Law Enforcement Officers). Washington, D.C.

United States. Federal Emergency Management Agency, United States Fire Administration. *Emergency Preparedness U.S.A. Course*. HS-2. September 1992.

United States. Federal Emergency Management Agency, United States Fire Administration. *Emergency Vehicle Driver Training*. FA-110. September 1991.

STATE

Office of Advisory Council. *Driver Training Manual*. Phoenix, AZ:Arizona Law Enforcement Advisory Council. August 1989

Texas Dept. of Transportation. *Emergency Medical Service Driver Instructor Course - Volumes I & II*. Law Enforcement and Security Training Division, Texas Engineering Extension Service, Texas A & M University. 1992

Texas Dept. of Transportation. *Emergency Medical Service Driving Range Technician Course Curriculum*. Law Enforcement and Security Training Division, Texas Engineering Extension Service, Texas A & M University. 1992

Texas Dept. of Transportation. *Emergency Medical Service Emergency Vehicle Operator Course Curriculum*. Law Enforcement and Security Training Division, Texas Engineering Extension Service, Texas A & M University. 1994

Commonwealth of Virginia. *Emergency Vehicle Operator's Curriculum Guide - Instructor & Student Manuals*. Virginia Association of Volunteer Rescue Squads Inc. and Commonwealth of Virginia Fire Programs/Fire Services Board.

Minnesota Technical College System. *Emergency Vehicle Driving Program*. St. Paul, MN:Fire Departments & EMS Ambulance Services. 1993

Indiana Emergency Medical Services. *Certified Driver*. Indianapolis, IN:Indiana Emergency Medical Services Commission.

OTHER

OPERATOR STANDARDS/REQUIREMENTS/TESTING

Commercial Driver Testing and Licensing Standards:Final Rule. 49 CFR 391. Federal Register.

Qualification of Drivers: Final Rule. 49 CFR 383. Federal Register.

United States. Dept. of the Army. *Prehospital Emergency Care & Transportation*. Army Ambulance Requirements. HSC Pamphlet 40-7-18. 21 July, 1992.

United States. Dept. of Transportation, National Highway Traffic Safety Administration
Functional Aspects of Driver Impairment: A Guide for State Medical Advisory Boards.

United States. Dept. of Transportation, National Highway Traffic Safety Administration.
Screening for Driver Limitation. October 1976.

United States. Dept. of Transportation, National Highway Traffic Safety Administration. *Status of Medical Review in Driver Licensing: Policies, Programs & Standards*. March 1992

GENERAL INFORMATION/TRAINING HINTS

Clawson, J.J. "The Maximal Response Disease: 'Red Lights and Siren' Syndrome in Priority

Dispatching". *Journal of Emergency Medical Services*. January 1987.

Clawson, J.J. and R.L. Martin. "Modern Priority Dispatch." *Emergency Training*. January 1990.

Emergency Medical Response Task Force (J.J. Clawson et al.) "Use of Warning Lights and Siren in Emergency Medical Vehicle Response and Patient Transport." *Prehospital and Disaster Medicine*. Vol. 9, No. 2. April-June 1994.

Federal Emergency Management Agency, Emergency Management Institute. *Catalog of Activities 1993-1994*. Emmitsburg, MD.

Federal Emergency Management Agency, United States Fire Administration. *Alive on Arrival*. Washington, DC. August 1992

Federal Emergency Management Agency, United States Fire Administration. *Federal Agencies in EMS*. Washington, DC. August 1993

Federal Emergency Management Agency, United States Fire Administration. *Resources on Fire & Emergency Medical Services (EMS)*. September 1993.

Pirrallo, R.G. "Fatal Ambulance Crashes During Emergency & Non-Emergency Operation." *Emergency Training*.

Virginia Association of Volunteer Rescue Squads, Inc. *Training Brochure*. 13 October 1993.

SURVEYS & ANALYSES

Pirrallo, R.G. and R.A. Swor. "Characteristics of Fatal Ambulance Crashes During Emergency and Non-emergency Operation." *Prehospital and Disaster Medicine*. Vol. 9, No. 2. April-June 1994.

Saunders, C.E. and C.J. Heye. "Ambulance Collisions in an Urban Environment." *Prehospital and Disaster Medicine*. Vol. 9, No. 2. April-June 1994.

United States Fire Administration. *Survey of Fire Apparatus Driver Training Programs*. Arlington, VA:TriData Corporation. October 1991.

United States. Dept. of Transportation, National Highway Traffic Safety Administration. *Emergency Medical Services - 1990 and Beyond*. Washington, DC. October 1990.

